

CONSTRUCTION SERVICES AGREEMENT

Contract 21-03456BM

Bus Real Time Information (RTI) Construction Services

This Construction Services Agreement is entered into and made effective as of the date of last signature below (the "Effective Date") by and between UTAH TRANSIT AUTHORITY, a public transit district organized under the laws of the State of Utah ("UTA"), and SKYLINE ELECTRIC COMPANY ("Contractor").

RECITALS

- A. UTA desires to hire Contractor for Bus RTI Construction Services per the Specifications and Bid Schedule contained in the RFP.
- B. On July 19, 2021, UTA issued Request for Proposal Package Number 21-03456BM ("RFP") encouraging interested parties to submit proposals to perform the services described in the RFP.
- C. Upon evaluation of the proposals submitted in response to the RFP, UTA selected Contractor as the preferred entity with whom to negotiate a contract to perform the Work.
- D. Contractor is qualified and willing to perform the Work as set forth in the Scope of Services.

AGREEMENT

NOW, THEREFORE, in accordance with the foregoing Recitals, which are incorporated herein by reference, and for and in consideration of the mutual covenants and agreements hereafter set forth, the mutual benefits to the parties to be derived herefrom, and for other valuable consideration, the receipt and sufficiency of which the parties acknowledge, it is hereby agreed as follows:

1. SERVICES TO BE PROVIDED

- a. Contractor shall perform all Work as set forth in the Scope of Services (Exhibit A). Except for items (if any) which this Contract specifically states will be UTA-provided, Contractor shall furnish all the labor, material and incidentals necessary for the Work.
- b. Contractor shall perform all Work under this Contract in a professional manner, using at least that standard of care, skill and judgment which can reasonably be expected from similarly situated professionals.
- c. All Work shall conform to generally accepted standards in the transit industry. Contractor shall perform all Work in compliance with applicable laws, regulations, rules, ordinances, permit

constraints and other legal requirements including, without limitation, those related to safety and environmental protection.

- d. Contractor shall furnish only qualified personnel and materials necessary for the performance of the Work.
- e. When performing Work on UTA property, Contractor shall comply with all UTA work site rules including, without limitation, those related to safety and environmental protection.

2. MANAGEMENT OF WORK

- a. Contractor's Project Manager will be the day-to-day contact person for Contractor and will be responsible for all Work, as well as the coordination of such Work with UTA.
- b. UTA's Project Manager will be the day-to-day contact person for UTA, and shall act as the liaison between UTA and Contractor with respect to the Work. UTA's Project Manager shall also coordinate any design reviews, approvals or other direction required from UTA with respect to the Work.

3. PROGRESS OF WORK

- a. Contractor shall prosecute the Work in a diligent and continuous manner and in accordance with all applicable notice to proceed, critical path schedule and guaranteed completion date requirements set forth in (or developed and agreed by the parties in accordance with) the Scope of Services.
- b. Contractor shall conduct regular meetings to update UTA's Project Manager regarding the progress of the Work including, but not limited to, any unusual conditions or critical path schedule items that could affect or delay the Work. Such meetings shall be held at intervals mutually agreed to between the parties.
- c. Contractor shall deliver monthly progress reports and provide all Contract submittals and other deliverables as specified in the Scope of Services.
- d. Any drawing or other submittal reviews to be performed by UTA in accordance with the Scope of Services are for the sole benefit of UTA, and shall not relieve Contractor of its responsibility to comply with the Contract requirements.
- e. UTA will have the right to inspect, monitor and review any Work performed by Contractor hereunder as deemed necessary by UTA to verify that such Work conforms to the Contract requirements. Any such inspection, monitoring and review performed by UTA is for the sole benefit of UTA, and shall not relieve Contractor of its responsibility to comply with the Contract requirements.
- f. UTA shall have the right to reject Work which fails to conform to the requirements of this Contract. Upon receipt of notice of rejection from UTA, Contractor shall (at its sole expense and without entitlement to equitable schedule relief) promptly re-perform, replace or re-execute the Work so as to conform to the Contract requirements.
- g. If Contractor fails to promptly remedy rejected Work as provided in Section 3.6, UTA may (without limiting or waiving any rights or remedies it may have) perform necessary corrective action using other contractors or UTA's own forces. Any costs reasonably incurred by UTA in such corrective action shall be chargeable to Contractor.

4. PERIOD OF PERFORMANCE

This Contract shall commence as of the Effective Date. This Contract shall remain in full force and effect until all Work is completed in accordance with this Contract, as reasonably determined by UTA. Contractor shall complete all Work no later than October 31, 2022. This guaranteed completion date may be extended if Contractor and UTA mutually agree to an extension evidenced by a written Change Order. The rights and obligations of UTA and Contractor under this Contract shall at all times be subject to and conditioned upon the provisions of this Contract.

5. COMPENSATION

- a. For the performance of the Work, UTA shall pay Contractor in accordance with the payments provisions described in Exhibit B. Payments shall be made in accordance with the milestones or other payment provisions detailed in Exhibit B. If Exhibit B does not specify any milestones or other payment provisions, then payment shall be made upon completion of all Work and final acceptance thereof by UTA.
- b. To the extent that Exhibit B or another provision of this Contract calls for any portion of the consideration to be paid on a cost-reimbursement basis, such costs shall only be reimbursable to the extent allowed under 2 CFR Part 200 Subpart E. Compliance with federal cost principles shall apply regardless of funding source for this Contract.
- c. To the extent that Exhibit B or another provision of this Contract calls for any portion of the consideration to be paid on a time and materials or labor hour basis, then Contractor must refer to the not-to-exceed amount, maximum Contract amount, Contract budget amount or similar designation (any of these generically referred to as the “Not to Exceed Amount”) specified in Exhibit B (as applicable). Unless and until UTA has notified Contractor by written instrument designated or indicated to be a Change Order that the Not to Exceed Amount has been increased (which notice shall specify a revised Not to Exceed Amount): (i) Contractor shall not be obligated to perform services or incur costs which would cause its total compensation under this Contract to exceed the Not to Exceed Amount; and (ii) UTA shall not be obligated to make payments which would cause the total compensation paid to Contractor to exceed the Not to Exceed Amount.
- d. UTA may withhold and/or offset from payment any amounts reasonably reflecting: (i) items of Work that have been rejected by UTA in accordance with this Contract; (ii) invoiced items that are not payable under this Contract; or (iii) amounts Contractor owes to UTA under this Contract.

6. INCORPORATED DOCUMENTS

- a. The following documents hereinafter listed in chronological order, with most recent document taking precedence over any conflicting provisions contained in prior documents (where applicable), are hereby incorporated into the Contract by reference and made a part hereof:

1. The terms and conditions of this Construction Services Agreement

2. The Addendum 1 Supplemental Terms and Conditions for Construction Services. (including any exhibits and attachments hereto).
3. Contractor's Proposal including, without limitation, all federal certifications (as applicable);
4. UTA's RFP including, without limitation, all attached or incorporated terms, conditions, federal clauses (as applicable), drawings, plans, specifications and standards and other descriptions of the Construction Services;

b. The above-referenced documents are made as fully a part of the Contract as if hereto

7. ORDER OF PRECEDENCE

The Order of Precedence for this contract is as follows:

1. UTA Contract including all terms and conditions and attachments
2. Addendum 1 Supplemental Terms and Conditions for Construction Services
3. UTA Solicitation Terms
4. Contractor's Bid or Proposal including proposed terms or conditions

Any contractor proposed term or condition which is in conflict with a UTA contract or solicitation term or condition will be deemed null and void.

8. INVOICING PROCEDURES

- a. Contractor shall submit invoices to UTA's Project Manager for processing and payment in accordance with Exhibit B. If Exhibit B does not specify invoice instructions, then Contractor shall invoice UTA after completion of all Work and final acceptance thereof by UTA. Invoices shall be provided in the form specified by UTA. Reasonable supporting documentation demonstrating Contractor's entitlement to the requested payment must be submitted with each invoice.
- b. UTA shall have the right to disapprove (and withhold from payment) specific line items of each invoice to address non-conforming Work or invoicing deficiencies. Approval by UTA shall not be unreasonably withheld. UTA shall have the right to offset from payment amounts reasonably reflecting the value of any claim which UTA has against Contractor under this Contract. Payment for all invoice amounts not specifically disapproved by UTA shall be provided to Contractor within thirty (30) calendar days of invoice submittal.

9. OWNERSHIP OF DESIGNS, DRAWINGS, AND WORK PRODUCT

Any deliverables prepared or developed pursuant to the Contract including without limitation drawings, specifications, manuals, calculations, maps, sketches, designs, tracings, notes, reports, data, computer programs, models and samples, shall become the property of UTA when prepared, and, together with any documents or information furnished to Contractor and its employees or agents by UTA hereunder, shall be delivered to UTA upon request, and, in any event, upon termination or final acceptance of the Goods and Services. UTA shall have full rights and privileges to use and reproduce said items. To the extent that any deliverables include or incorporate preexisting intellectual property of Contractor,

Contractor hereby grants UTA a fully paid, perpetual license to use such intellectual property for UTA's operation, maintenance, modification, improvement and replacement of UTA's assets. The scope of the license shall be to the fullest extent necessary to accomplish those purposes, including the right to share same with UTA's contractors, agent, officers, directors, employees, joint owners, affiliates and Contractors.

10. USE OF SUBCONTRACTORS

- a. Contractor shall give advance written notification to UTA of any proposed subcontract (not indicated in Contractor's Proposal) negotiated with respect to the Work. UTA shall have the right to approve all subcontractors, such approval not to be withheld unreasonably.
- b. No subsequent change, removal or substitution shall be made with respect to any such subcontractor without the prior written approval of UTA.
- c. Contractor shall be solely responsible for making payments to subcontractors, and such payments shall be made within thirty (30) days after Contractor receives corresponding payments from UTA.
- d. Contractor shall be responsible for and direct all Work performed by subcontractors.
- e. Contractor agrees that no subcontracts shall provide for payment on a cost-plus-percentage-of-cost basis. Contractor further agrees that all subcontracts shall comply with all applicable laws.

11. KEY PERSONNEL

Contractor shall provide the key personnel as indicated in Contractor's Proposal (or other applicable provisions of this Contract), and shall not change any of said key personnel without the express written consent of UTA.

12. INFORMATION, RECORDS and REPORTS; AUDIT RIGHTS

Contractor shall retain all books, papers, documents, accounting records and other evidence to support any cost-based billings allowable under Exhibit B (or any other provision of this Contract). Such records shall include, without limitation, time sheets and other cost documentation related to the performance of labor services, as well as subcontracts, purchase orders, other contract documents, invoices, receipts or other documentation supporting non-labor costs. Contractor shall also retain other books and records related to the performance, quality or management of this Contract and/or Contractor's compliance with this Contract. Records shall be retained by Contractor for a period of at least six (6) years after completion of the Work, or until any audit initiated within that six-year period has been completed (whichever is later). During this six-year period, such records shall be made available at all reasonable times for audit and inspection by UTA and other authorized auditing parties including, but not limited to, the Federal Transit Administration. Copies of requested records shall be furnished to UTA or designated audit parties upon request. Contractor agrees that it shall flow-down (as a matter of written contract) these records requirements to all subcontractors utilized in the performance of the Work at any tier.

13. FINDINGS CONFIDENTIAL

Any documents, reports, information, or other data and materials available to or prepared or assembled by Contractor or subcontractors under this Contract are considered confidential and shall not be made available to any person, organization, or entity by Contractor without consent in writing from UTA.

It is hereby agreed that the following information is not considered to be confidential:

- a. Information already in the public domain;
- b. Information disclosed to Contractor by a third party who is not under a confidentiality obligation;
- c. Information developed by or in the custody of Contractor before entering into this Contract;
- d. Information developed by Contractor through its work with other clients; and
- e. Information required to be disclosed by law or regulation including, but not limited to, subpoena, court order or administrative order.

14. PUBLIC INFORMATION.

Contractor acknowledges that the Contract and related materials (invoices, orders, etc.) will be public documents under the Utah Government Records Access and Management Act (GRAMA). Contractor's response to the solicitation for the Contract will also be a public document subject to GRAMA, except for legitimate trade secrets, so long as such trade secrets were properly designated in accordance with terms of the solicitation.

15. GENERAL INDEMNIFICATION

Contractor shall indemnify, hold harmless and defend UTA, its officers, trustees, agents, and employees (hereinafter collectively referred to as "Indemnitees") from and against all liabilities, claims, actions, damages, losses, and expenses including without limitation reasonable attorneys' fees and costs (hereinafter referred to collectively as "claims") related to bodily injury, including death, or loss or damage to tangible or intangible property caused, or alleged to be caused, in whole or in part, by the acts or omissions of Contractor or any of its owners, officers, directors, agents, employees or subcontractors. This indemnity includes any claim or amount arising out of the failure of such Contractor to conform to federal, state, and local laws and regulations. If an employee of Contractor, a subcontractor, anyone employed directly or indirectly by any of them or anyone for whose acts any of them may be liable brings a claim against UTA or another Indemnitee, Contractor's indemnity obligation set forth above will not be limited by any limitation on the amount of damages, compensation or benefits payable under any employee benefit acts, including workers' compensation or disability acts. The indemnity obligations of Contractor shall not apply to the extent that claims arise out of the sole negligence of UTA or the Indemnitees.

16. INSURANCE REQUIREMENTS

The insurance requirements herein are minimum requirements for this Contract and in no way limit the indemnity covenants contained in this Contract. The Utah Transit Authority in no way warrants that the minimum limits contained herein are sufficient to protect the Contractor from liabilities that might arise out of the performance of the work under this contract by the Contractor, his agents, representatives, employees or subcontractors and Contractor is free to purchase

additional insurance as may be determined necessary.

A. **MINIMUM SCOPE AND LIMITS OF INSURANCE:** Contractor shall provide coverage with limits of liability not less than those Stated below. An excess liability policy or umbrella liability policy may be used to meet the minimum liability requirements provided that the coverage is written on a “following form” basis.

1. Commercial General Liability – Occurrence Form

Policy shall include bodily injury, property damage and broad form contractual liability coverage.

- General Aggregate \$4,000,000
- Products – Completed Operations Aggregate \$1,000,000
- Personal and Advertising Injury \$1,000,000
- Each Occurrence \$2,000,000

a. The policy shall be endorsed to include the following additional insured language: "The Utah Transit Authority shall be named as an additional insured with respect to liability arising out of the activities performed by, or on behalf of the Contractor".

2. Automobile Liability

Bodily Injury and Property Damage for any owned, hired, and non-owned vehicles used in the performance of this Contract.

Combined Single Limit (CSL) \$2,000,000

a. The policy shall be endorsed to include the following additional insured language: "The Utah Transit Authority shall be named as an additional insured with respect to liability arising out of the activities performed by, or on behalf of the Contractor, including automobiles owned, leased, hired or borrowed by the Contractor".

3. Worker's Compensation and Employers' Liability

Workers' Compensation Statutory

Employers' Liability

- Each Accident \$100,000
- Disease – Each Employee \$100,000
- Disease – Policy Limit \$500,000

- a. Policy shall contain a waiver of subrogation against the Utah Transit Authority.
- b. This requirement shall not apply when a contractor or subcontractor is exempt under UCA 34A-2-103, AND when such contractor or subcontractor executes the appropriate waiver form.

4. Professional Liability (Errors and Omissions Liability)

The policy shall cover professional misconduct or lack of ordinary skill for those positions defined in the Scope of Services of this contract.

Each Claim	\$1,000,000
Annual Aggregate	\$2,000,000

- a. In the event that the professional liability insurance required by this Contract is written on a claims-made basis, Contractor warrants that any retroactive date under the policy shall precede the effective date of this Contract; and that either continuous coverage will be maintained or an extended discovery period will be exercised for a period of three (3) years beginning at the time work under this Contract is completed.

5. Railroad Protective Liability Insurance (RRPLI)

During construction and maintenance within fifty (50) feet of an active railroad track, including but not limited to installation, repair or removal of facilities, equipment, services or materials, the Licensee and/or Licensee’s Contractor must maintain “Railroad Protective Liability” insurance on behalf of UTA only as named insured, with a limit of not less than \$2,000,000 per occurrence and an aggregate of \$6,000,000.

If the Licensee and/or Licensee’s Contractor is not enrolling for this coverage under UTA’s blanket RRPLI program, the policy provided must have the definition of “JOB LOCATION” AND “WORK” on the declaration page of the policy shall refer to this Agreement and shall describe all WORK or OPERATIONS performed under this Agreement.

B. ADDITIONAL INSURANCE REQUIREMENTS: The policies shall include, or be endorsed to include, the following provisions:

- 1. On insurance policies where the Utah Transit Authority is named as an additional insured, the Utah Transit Authority shall be an additional insured to the full limits of liability purchased by the Consultant. Insurance limits indicated in this agreement are minimum limits. Larger limits may be indicated after the consultant’s assessment of the exposure for this contract; for their own protection and the protection of UTA.
- 2. The Contractor's insurance coverage shall be primary insurance and non-contributory

with respect to all other available sources.

- C. NOTICE OF CANCELLATION: Each insurance policy required by the insurance provisions of this Contract shall provide the required coverage and shall not be suspended, voided or canceled except after thirty (30) days prior written notice has been given to the Utah Transit Authority, except when cancellation is for non-payment of premium, then ten (10) days prior notice may be given. Such notice shall be sent directly to (Utah Transit Authority agency Representative's Name & Address).
- D. ACCEPTABILITY OF INSURERS: Insurance is to be placed with insurers duly licensed or authorized to do business in the State and with an "A.M. Best" rating of not less than A-VII. The Utah Transit Authority in no way warrants that the above-required minimum insurer rating is sufficient to protect the Contractor from potential insurer insolvency.
- E. VERIFICATION OF COVERAGE: Contractor shall furnish the Utah Transit Authority with certificates of insurance (on standard ACORD form) as required by this Contract. The certificates for each insurance policy are to be signed by a person authorized by that insurer to bind coverage on its behalf.

All certificates and any required endorsements are to be sent to insurancecerts@rideuta.com and received and approved by the Utah Transit Authority before work commences. Each insurance policy required by this Contract must be in effect at or prior to commencement of work under this Contract and remain in effect for the duration of the project. Failure to maintain the insurance policies as required by this Contract or to provide evidence of renewal is a material breach of contract.

All certificates required by this Contract shall be emailed directly to Utah Transit Authority's insurance email address at insurancecerts@rideuta.com. The Utah Transit Authority project/contract number and project description shall be noted on the certificate of insurance. The Utah Transit Authority reserves the right to require complete, certified copies of all insurance policies required by this Contract at any time. DO NOT SEND CERTIFICATES OF INSURANCE TO THE UTAH TRANSIT AUTHORITY'S CLAIMS AND INSURANCE DEPARTMENT.

- F. SUBCONTRACTORS: Contractors' certificate(s) shall include all subcontractors as additional insureds under its policies or subcontractors shall maintain separate insurance as determined by the Contractor, however, subcontractor's limits of liability shall not be less than \$1,000,000 per occurrence / \$2,000,000 aggregate. Sub-contractors maintaining separate insurance shall name Utah Transit Authority as an additional insured on their policy. Blanket additional insured endorsements are not acceptable from sub-contractors. Utah Transit Authority must be scheduled as an additional insured on any sub-contractor policies.

- G. APPROVAL: Any modification or variation from the insurance requirements in this Contract shall be made by Claims and Insurance Department or the UTA Legal Services, whose decision shall be final. Such action will not require a formal Contract amendment, but may be made by administrative action.

17. OTHER INDEMNITIES

- a. Consultant shall protect, release, defend, indemnify and hold harmless UTA and the other Indemnitees against and from any and all Claims of any kind or nature whatsoever on account of infringement relating to Consultant's performance under this Contract. If notified promptly in writing and given authority, information and assistance, Consultant shall defend, or may settle at its expense, any suit or proceeding against UTA so far as based on a claimed infringement and Consultant shall pay all damages and costs awarded therein against UTA due to such breach. In case any portion of the Work is in such suit held to constitute such an infringement or an injunction is filed that interferes with UTA's rights under this Contract, Consultant shall, at its expense and through mutual agreement between the UTA and Consultant, either procure for UTA any necessary intellectual property rights, or modify Consultant's services or deliverables such that the claimed infringement is eliminated.
- b. Consultant shall: (i) protect, release, defend, indemnify and hold harmless UTA and the other Indemnitees against and from any and all liens or Claims made or filed against UTA or upon the Work or the property on which the Work is located on account of any labor performed or labor, services, and equipment furnished by subcontractors of any tier; and (ii) keep the Work and said property free and clear of all liens or claims arising from the performance of any Work covered by this Contract by Consultant or its subcontractors of any tier. If any lien arising out of this Contract is filed, before or after Work is completed, Consultant, within ten (10) calendar days after receiving from UTA written notice of such lien, shall obtain a release of or otherwise satisfy such lien. If Consultant fails to do so, UTA may take such steps and make such expenditures as in its discretion it deems advisable to obtain a release of or otherwise satisfy any such lien or liens, and Consultant shall upon demand reimburse UTA for all costs incurred and expenditures made by UTA in obtaining such release or satisfaction. If any non-payment claim is made directly against UTA arising out of non-payment to any subcontractor, Consultant shall assume the defense of such claim within ten (10) calendar days after receiving from UTA written notice of such claim. If Consultant fails to do so, Consultant shall upon demand reimburse UTA for all costs incurred and expenditures made by UTA to satisfy such claim.

18. INDEPENDENT CONTRACTOR

Contractor is an independent contractor and agrees that its personnel will not represent themselves as, nor claim to be, an officer or employee of UTA by reason of this Contract. Contractor is responsible to provide and pay the cost of all its employees' benefits.

19. PROHIBITED INTEREST

No member, officer, agent, or employee of UTA during his or her tenure or for one year thereafter shall

have any interest, direct or indirect, including prospective employment by Contractor in this Contract or the proceeds thereof without specific written authorization by UTA.

20. CLAIMS/DISPUTE RESOLUTION

- a. "Claim" means any disputes between UTA and the Contractor arising out of or relating to the Contract Documents including any disputed claims for Contract adjustments that cannot be resolved in accordance with the Change Order negotiation process set forth in Article 6. Claims must be made by written notice. The responsibility to substantiate claims rests with the party making the claim.
- b. Unless otherwise directed by UTA in writing, Contractor shall proceed diligently with performance of the Work pending final resolution of a Claim, including litigation. UTA shall continue to pay any undisputed payments related to such Claim.
- c. The parties shall attempt to informally resolve all claims, counterclaims and other disputes through the escalation process described below. No party may bring a legal action to enforce any term of this Contract without first having exhausted such process.
- d. The time schedule for escalation of disputes, including disputed requests for change order, shall be as follows:

Level of Authority	Time Limit
UTA's Project Manager/Contractor's Project Manager	Five calendar days
UTA's Director/Contractor Equivalent	Five calendar days
UTA's Chief Officer/Contractor Equivalent	Five calendar days

Unless otherwise directed by UTA's Project Manager, Contractor shall diligently continue performance under this Contract while matters in dispute are being resolved.

If the dispute cannot be resolved informally in accordance with the escalation procedures set forth above, than either party may commence formal mediation under the Juris Arbitration and Mediation (JAMS) process using a mutually agreed upon JAMS mediator. If resolution does not occur through Mediation, then legal action may be commenced in accordance the venue and governing law provisions of this contract.

21. GOVERNING LAW

This Contract shall be interpreted in accordance with the substantive and procedural laws of the State of Utah. Any litigation between the parties arising out of or relating to this Contract will be conducted exclusively in federal or state courts in the State of Utah and Contractor consents to the jurisdiction of such courts.

22. ASSIGNMENT OF CONTRACT

Contractor shall not assign, sublet, sell, transfer, or otherwise dispose of any interest in this Contract

without prior written approval of UTA, and any attempted transfer in violation of this restriction shall be void.

23. NONWAIVER

No failure or waiver or successive failures or waivers on the part of either party in the enforcement of any condition, covenant, or article of this Contract shall operate as a discharge of any such condition, covenant, or article nor render the same invalid, nor impair the right of either party to enforce the same in the event of any subsequent breaches by the other party.

24. NOTICES OR DEMANDS

Any formal notice or demand to be given by one party to the other shall be given in writing by one of the following methods: (i) hand delivered; (ii) deposited in the mail, properly stamped with the required postage; (iii) sent via registered or certified mail; or (iv) sent via recognized overnight courier service. All such notices shall be addressed as follows:

If to UTA:
Utah Transit Authority
ATTN: Brian Motes
669 West 200 South
Salt Lake City, UT 84101

with a required copy to:
Utah Transit Authority
ATTN: Legal Counsel
669 West 200 South
Salt Lake City, UT 84101

~~If to Contractor:~~
Syline Electric Company
Attn: Cade Markle
1848 West 2300 South
West Valley City, UT 84119

Skyline

- a. Any such notice shall be deemed to have been given, and shall be effective, on delivery to the notice address then applicable for the party to which the notice is directed; provided, however, that refusal to accept delivery of a notice or the inability to deliver a notice because of an address change which was not properly communicated shall not defeat or delay the giving of a notice. Either party may change the address at which such party desires to receive written notice by providing written notice of such change to any other party.
- b. Notwithstanding Section 23.1, the parties may, through mutual agreement, develop alternative communication protocols to address change notices, requests for information and similar categories of communications. Communications provided pursuant to such agreed means shall be recognized as valid notices under this Contract.

25. CONTRACT ADMINISTRATOR

UTA's Contract Administrator for this Contract is Brian Motes, or designee. All questions and correspondence relating to the contractual aspects of this Contract should be directed to said Contract Administrator, or designee.

27. INSURANCE COVERAGE REQUIREMENTS FOR CONTRACTOR EMPLOYEES

- a. The following requirements apply to the extent that: (i) the initial value of this Contract is equal to or in excess of \$2 million; (ii) this Contract, with subsequent modifications, is reasonably anticipated to equal or exceed \$2 million; (iii) Contractor has a subcontract at any tier that involves a sub-Contractor that has an initial subcontract equal to or in excess of \$1 million; or (iv) any subcontract, with subsequent modifications, is reasonably anticipated to equal or exceed \$1 million:
- b. Contractor shall, prior to the effective date of this Contract, demonstrate to UTA that Contractor has and will maintain an offer of qualified health insurance coverage (as defined by Utah Code Ann. § 17B-2a-818.5) for the Contractor’s employees and the employee’s dependents during the duration of this Contract.
- c. Contractor shall also demonstrate to UTA that subcontractors meeting the above-described subcontract value threshold have and will maintain an offer of qualified health insurance coverage (as defined by Utah Code Ann. § 17B-2a-818.5) for the subcontractor’s employees and the employee’s dependents during the duration of the subcontract.

28. COSTS AND ATTORNEYS FEES

If any party to this Agreement brings an action to enforce or defend its rights or obligations hereunder, the prevailing party shall be entitled to recover its costs and expenses, including mediation, arbitration, litigation, court costs and attorneys’ fees, if any, incurred in connection with such suit, including on appeal

29. NO THIRD PARTY BENEFICIARY

The parties enter in to this Contract for the sole benefit of the parties, in exclusion of any third party, and no third party beneficiary is intended or created by the execution of this Contract.

30. FORCE MAJEURE

pandemics, epidemics, 

Neither party to the Contract will be held responsible for delay or default caused by fire, riot, acts of God and/or war which are beyond that party's reasonable control. UTA may terminate the Contract after determining such delay or default will reasonably prevent successful performance of the Contract.

31. SEVERABILITY

Any provision of this Contract prohibited or rendered unenforceable by operation of law shall be ineffective only to the extent of such prohibition or unenforceability without invalidating the remaining provisions of this Contract.

32. UTAH ANTI-BOYCOTT OF ISRAEL ACT

Contractor agrees it will not engage in a boycott of the State of Israel for the duration of this contract.

33. ENTIRE AGREEMENT

This Contract shall constitute the entire agreement and understanding of the parties with respect to the subject matter hereof, and shall supersede all offers, negotiations and other agreements with respect thereto. The terms of the Contract supersede any additional or conflicting terms or provisions that may be preprinted on Vendor's work plans, cost estimate forms, receiving tickets, invoices, or any other related standard forms or documents of Vendor that may subsequently be used to implement, record, or invoice Goods and/or Services hereunder from time to time, even if such standard forms or documents have been signed or initialed by a representative of UTA. The terms of the Contract prevail in any dispute between the terms of the Contract and the terms printed on any such standard forms or documents, and such standard forms or documents will not be considered written amendments of the Contract.

34. AMENDMENTS

Any amendment to this Contract must be in writing and executed by the authorized representatives of each party.

35. COUNTERPARTS

This Contract may be executed in any number of counterparts and by each of the parties hereto on separate counterparts, each of which when so executed and delivered shall be an original, but all such counterparts shall together constitute but one and the same instrument. Any signature page of the Contract may be detached from any counterpart and reattached to any other counterpart hereof. The electronic transmission of a signed original of the Contract or any counterpart hereof and the electronic retransmission of any signed copy hereof shall be the same as delivery of an original.

36. SURVIVAL

Provisions of this Contract intended by their nature and content to survive termination of this Contract shall so survive including, but not limited to, Articles 5, 7, 8, 10, 14, 15, 17, 18, 19, 20, 23, 29 and 30.

UTAH TRANSIT AUTHORITY:

By _____
Name _____
Title _____
Date _____

By _____
Name _____
Title _____
Date _____

DocuSigned by:
By Michael L. Bell
UTA 70E33A415BA44F6...
Name Michael L. Bell
Date 10/20/2021

SKYLINE ELECTRIC:

By 
Name Todd Shaffer
Title President
Date 10/19/21

By _____
Name _____
Title _____
Date _____

By _____

Project Manger

Name _____

Date _____

Addendum 1- Supplemental Terms and Conditions for Construction

ARTICLE 1

- 1.1 **Cooperation.** UTA and Contractor commit at all times to cooperate fully with each other, and proceed on the basis of trust and good faith, so as to permit each party to realize the benefits afforded under the Contract Documents.
- 1.2 **Professional Standards.** Contractor shall perform the Work in a good and workmanlike manner, and shall use reasonable skill, care, and diligence. If the Work includes professional services, Contractor shall perform those services in a professional manner, using at least that standard of care, skill and judgment that can reasonably be expected from similarly situated professionals.
- 1.3 **Definitions.** Terms that are defined in the Agreement have the same definition in all the Contract Documents, including in these General Conditions. Unless expressly modified by the Agreement, the following definitions shall also apply to all Contract Documents:

“**Agreement**” means the document signed by Contractor and UTA to which these General Conditions are attached as an exhibit or into which these General Conditions are incorporated by reference.

“**Application for Payment**” shall mean an invoice for a progress or final payment made in accordance with the requirements of Article 4.

“**Basis of Design Documents**” means those preliminary drawings, concept design drawings, technical requirements, performance requirements, project criteria, or other documents that are (i) included in the Contract Documents, and (ii) serve as the basis or starting point for design services to be performed by Contractor, if any.

“**Claim**” has the meaning indicated in Section 8.1 of these General Conditions.

“**Construction Documents**” means the final drawings and specifications that set forth in detail the requirements for construction of the Project.

“**Contract Documents**” means those documents designated as Contract Documents in the Agreement.

“**Contract Times**” means the guaranteed dates for Substantial Completion, Final Completion (if applicable), and any other deadlines for completion of the Work, or a part thereof, all as set forth in the Agreement.

“**Contractor**” means the entity that has entered into a contract with UTA to perform

construction and other services as detailed in the Contract Documents. The Contractor may be a Design-Builder, general contractor, Construction Manager/General Contractor, or other type of entity.

“**Day**” means a calendar day unless otherwise specifically noted in the Contract Documents.

“**Differing Site Condition**” has the meaning indicated in Section 3.2 of these General Conditions.

“**Final Completion**” has the meaning indicated in Section 4.7 of these General Conditions.

“**Force Majeure Event**” means a delay ^{or change} caused by any national or general strikes, fires, riots, acts of God, acts of the public enemy, floods, acts of terrorism, unavoidable transportation accidents or embargoes, or other events: (i) which are not reasonably foreseeable as of the date the Agreement was executed; (ii) which are attributable to a cause beyond the control and without the fault or negligence of the party incurring such delay; and (iii) the effects of which cannot be avoided or mitigated by the party claiming such Force Majeure Event through the use of commercially reasonable efforts. The term Force Majeure Event does not include a delay caused by seasonal weather conditions, inadequate construction forces, general economic conditions, ~~changes in the costs of goods, or Contractor’s failure to place orders for equipment, materials, construction equipment or other items sufficiently in advance to ensure that the Work is completed in accordance with the Contract Documents.~~

^{pandemics, epidemics, supply-chain disruptions}

“**General Conditions**” means this document.

“**Legal Requirements**” means all applicable federal, state, and local laws, codes, ordinances, rules, regulations, orders and decrees of any government or quasi-government entity having jurisdiction over the Project or Site, the practices involved in the Project or Site, or any Work including, without limitation, those related to safety and environmental protection. The terms Legal Requirements shall also include any requirements or conditions included in a permit required for, or issued in conjunction with, the Project.

“**Potential Change Notice**” has the meaning indicated in Section 7.3 of these General Conditions.

“**Project**” means the construction project described in the Agreement.

“**Punchlist**” means shall mean a schedule of Work items (developed in accordance with the procedures described in Article 4) which remain to be completed prior to Final Completion, but which do not adversely affect the performance, operability, capacity, efficiency, reliability, cost effectiveness, safety or use of the Project after Substantial Completion.

“**Schedule of Values**” means the detailed statement furnished by Contractor and approved by UTA in accordance with Section 4.1, which statement outlines the various components of the Contract Price and allocates values for all such components in a manner that can be used for preparing and reviewing invoices.

“**Site**” means the land or premises on which the Project is located, as more particularly defined and described in the Contract Documents.

“**Subcontractor**” means any person or entity (including subcontractors at any tier, design engineers, laborers and materials suppliers) retained by Contractor or any other Subcontractor to perform a portion of Contractor’s obligations under the Contract Documents.

“**Substantial Completion**” or “**Substantially Complete**” has the meaning indicated in Section 4.6 of these General Conditions.

“**Work**” means all obligations, duties, requirements, and responsibilities for the successful completion of the Project by Contractor, including furnishing of all services and/or equipment (including obtaining all applicable licenses and permits to be acquired by Contractor) in accordance with the Contract Documents.

ARTICLE 2 **Contractor’s Services**

2.1 General Services.

- 2.1.1 Contractor’s Project Manager shall be reasonably available to UTA and shall have the necessary expertise and experience required to supervise the Work. Contractor’s Project Manager shall communicate regularly with UTA and shall be vested with the authority to act on behalf of Contractor.
- 2.1.2 Contractor shall provide UTA with a monthly status report detailing the progress of the Work, including: (i) whether the Work is proceeding according to schedule; (ii) whether discrepancies, conflicts, or ambiguities exist in the Contract Documents that require resolution; (iii) whether unusual health and safety issues exist in connection with the Work; and (iv) other items that require resolution so as not to jeopardize Contractor’s ability to complete the Work for the Contract Price and within the Contract Time(s).
- 2.1.3 Unless a schedule for the execution of the Work has been attached to the Agreement as an exhibit at the time the Agreement is executed, Contractor shall prepare and submit, within seven (7) Days of the execution of the Agreement, a schedule for the execution of the Work for UTA’s review and response. The schedule must indicate the dates for the start and completion of the various stages of Work, including the required dates when UTA obligations must be completed to enable Contractor to achieve the Contract Time(s). Such UTA obligation dates may include (where contemplated in the Contract Documents): (i) Site availability requirements; and/or (ii) dates when UTA information or approvals are required. The schedule shall be revised as required by conditions and progress of the Work, but such revisions shall not relieve Contractor of its obligations to complete the Work within the Contract Time(s), as such dates may be adjusted in accordance with the Contract Documents. UTA’s review of, and response to, the schedule shall not be construed as relieving Contractor of its complete and exclusive control over the means, methods, sequences and techniques for executing the Work.

2.2 Design Services. If the Work includes any design services, provisions 2.2.1 through 2.2.8 apply.

- 2.2.1 Contractor shall provide the necessary design services, including architectural, engineering and other design professional services, for the preparation of the required drawings, specifications and other design submittals to permit Contractor to complete the Work consistent with the Contract Documents. Contractor shall ensure that design services are performed by qualified, licensed design professionals employed by Contractor, or by qualified, independent licensed design consultants procured by Contractor.
- 2.2.2 Contractor and UTA shall, consistent with any applicable provision of the Contract Documents, agree upon any interim design submissions that UTA may wish to review, which setting forth the Project requirements. Interim design submissions must be consistent with the Basis of Design Documents, as the Basis of Design Documents may have been changed through the design process set forth in this Section 2.2.2. On or about the time of the scheduled submissions, Contractor and UTA shall meet and confer about the submissions, with Contractor identifying during such meetings, among other things, the evolution of the design and any changes to the Basis of Design Documents, or, if applicable, previously submitted design submissions. Changes to the Basis of Design Documents shall be processed in accordance with Article 7. Minutes of the meetings, including a full listing of all changes, will be maintained by Contractor and provided to all attendees for review. Following the design review meeting, UTA will be entitled to at least ten (10) Days to review and approve the interim design submissions and meeting minutes.
- 2.2.3 To the extent not prohibited by the Contract Documents or Legal Requirements, and with the approval of UTA, Contractor may prepare interim design submissions and portion of the Work prior to completion of the Construction Documents for the entire Work.
- 2.2.4 Contractor shall submit proposed Construction Documents to UTA, which must be consistent with the latest set of interim design submissions, as such submissions may have been modified in a design review meeting and recorded in the meeting minutes. The parties shall have a design review meeting to discuss, and UTA shall review and approve, the Construction Documents in accordance with the procedures set forth in Section 2.2.2 above. Contractor shall submit one set of approved Construction Documents to UTA prior to commencement of construction
- 2.2.5 UTA's review and approval of interim design submissions, meeting minutes, and Construction Documents is for the purpose of mutually establishing a conformed set of Contract Documents compatible with the requirements of the Work. Neither UTA's review nor approval of any interim design submissions, meeting minutes, and Construction Documents shall be deemed to: (i) relieve Contractor from its obligations to comply with the Contract Documents; (ii) relieve Contractor from its obligations with respect to the accuracy of the design submittals; or (iii) transfer any design liability from Contractor to UTA.
- 2.2.6 Upon completion of the Work, and as a condition to receiving final payment pursuant to Section 4.7, Contractor shall prepare and provide to UTA a final set of as-built drawings, depicting the Project as completed, including all changes to the Project made subsequent

to the approval of the Construction Documents.

- 2.2.7 All drawings, specifications, interim design submissions, Construction Documents, and other documents furnished by Contractor to UTA pursuant to the Contract Documents (those documents, the “Work Product”) are deemed to be instruments of service and Contractor shall retain the ownership and intellectual property rights therein.
- 2.2.8 Once UTA has made a corresponding payment for the Work required for Contractor to prepare any Work Product, Contractor will be deemed to have granted to UTA a license to use that Work Product in connection with the construction, occupancy, and maintenance of the Project, or any other UTA project or facility.

2.3 Government Approvals, Permits, and Legal Requirements.

- 2.3.1 Except where the Contract Documents expressly state that UTA will be responsible for a specific entitlement, Contractor shall obtain and pay for all necessary permits, approvals, licenses, government charges and inspection fees required for the prosecution of the Work by any government or quasi-government entity having jurisdiction over the Project or Site. Contractor shall provide reasonable assistance to UTA in obtaining any permits, approvals, and licenses that the Contract Documents expressly specify to be a UTA responsibility.
- 2.3.2 Contractor shall perform the Work in accordance with all Legal Requirements and shall provide all notices applicable to the Work as required by the Legal Requirements.
- 2.3.2 Contractor shall file a notice of commencement, a notice of completion, and other notices required by Utah Code Title 38 (Liens). Contractor shall file such notices in the manner and within the time periods required by law.
- 2.3.3 The Contract Price and/or Contract Time(s) will be adjusted to compensate Contractor for the effects of any changes in the Legal Requirements provided that such changes: (i) materially increase Contractor’s cost of, or time required for, the performance of the Work; and (ii) are enacted after the effective date of the Agreement.

2.4 Construction Services.

- 2.4.1 Contractor shall proceed with construction in accordance with the approved Construction Documents.
- 2.4.2 Except to the extent that the Contract Documents expressly identify UTA obligations related to the Work, Contractor shall provide through itself or Subcontractors the necessary supervision, labor, inspection, testing, start-up, material, equipment, machinery, temporary utilities and other temporary facilities (whether or not expressly stated or depicted in the Contract Documents or Construction Drawings) to permit Contractor to complete construction of the Project consistent with the Contract Documents.
- 2.4.3 Contractor is responsible for securing the Site until UTA issues a Certificate of Substantial

Completion.

- 2.4.4 Contractor shall perform all construction activities efficiently and with the requisite expertise, skill and competence to satisfy the requirements of the Contract Documents. Contractor shall at all times exercise complete and exclusive control over the means, methods, sequences, techniques and procedures of construction.
- 2.4.5 Contractor shall be solely responsible for initiating, maintaining and supervising all safety precautions and programs in connection with the Work. Contractor shall take necessary precautions for the safety of, and shall provide necessary protection to prevent damage, injury or loss to the following: (i) all Contractor, Subcontractor, UTA employees, the public and other persons who may be affected thereby; (ii) all Work and all equipment and materials to be incorporated into the Work; and (iii) other property at the Site or adjacent thereto. Contractor shall comply with the minimum standards imposed by UTA's Construction Safety and Security Program Manual, as updated from time to time (UTA's Construction Safety and Security Program Manual is incorporated into the Contract Documents by reference). However, Contractor shall be responsible for all additional as necessary to comply protect persons and property and comply with applicable Legal Requirements related to safety.
- 2.4.6 Contractor shall employ only Subcontractors who are duly licensed and qualified to perform the Work consistent with the Contract Documents. UTA may require Contractor to remove from the Project a Subcontractor or anyone employed directly or indirectly by any Subcontractor, if UTA reasonably concludes that the Subcontractor is creating safety risks at the Site or quality risks to the Project.
- 2.4.7 Contractor is responsible for the proper performance of the Work by Subcontractors and for any acts and omissions in connection with such performance. Nothing in the Contract Documents is intended or deemed to create any legal or contractual relationship between UTA and any Subcontractor, including but not limited to any third-party beneficiary rights.
- 2.4.8 Contractor shall coordinate the activities of all of its Subcontractors. If UTA performs other work on the Project or at the Site with separate contractors under UTA's control, Contractor agrees to reasonably cooperate and coordinate its activities with those of such separate contractors so that the Project can be completed in an orderly and coordinated manner without unreasonable disruption.
- 2.4.9 Contractor shall keep the Site reasonably free from debris, trash and construction wastes to permit Contractor to perform its construction services efficiently, safely and without interfering with the use of adjacent land areas. Upon Substantial Completion of the Work, or a portion of the Work, Contractor shall remove all debris, trash, construction wastes, materials, equipment, machinery and tools arising from the Work or applicable portions thereof to permit UTA to occupy the Project or a portion of the Project for its intended use.

2.5 Quality Control, Quality Assurance, Inspection, Rejection and Correction of Work.

- 2.5.1 Contractor shall develop a Project-specific construction quality control plan as

contemplated in UTA's Quality Management Plan and Construction Quality Plan. The Contractor's plan shall satisfy the minimum requirement imposed by UTA's Construction Quality Plan and shall be sufficient to ensure that Work is performed in compliance with the Contract Documents. If the Work includes any design services, Contractor shall also develop and thereafter comply with a design quality plan that meets the minimum requirements set forth in the UTA Design Quality Plan. The UTA Quality Management Plan, Construction Quality Plan and Design Quality Plan are incorporated into the Contract Documents by reference. The Contractor's plans shall be subject to UTA's review and approval.

- 2.5.2 Contractor shall comply with the approved quality control plan(s). Responsibilities shall include inspection and testing and related activities including administration, management, supervision, reports, record keeping and use of independent testing agencies and laboratories. Contractor shall provide evidence of compliance with the Contract Documents.
- 2.5.3 UTA will have the right to audit and spot check the Contractor's quality control procedures and documentation. This will include the Company's right to inspect and test all Work at reasonable times. Contractor shall cooperate with any inspection and testing performed by UTA. All contractor-furnished materials and supplies shall be subject to inspection at the point of manufacture.
- 2.5.2 Any inspection and testing performed by UTA shall be for the sole and exclusive benefit of UTA. Neither inspection and testing of Work, nor the lack of same nor acceptance of the Work by UTA, nor payment therefore shall relieve Contractor from any of its obligations under the Contract Documents.
- 2.5.3 At any time prior to Substantial Completion, UTA may reject Work which fails to conform to the Contract Documents. Contractor shall, at its sole expense, promptly re-perform or correct any Work so as to conform to the requirements of the Contract. Contractor shall not be entitled to an adjustment to the Contract Price and/or Contract Times with respect to any corrective action necessary to rectify non-conforming Work.
- 2.5.4 If Contractor fails to promptly remedy rejected Work, UTA may, without limiting or waiving any other rights or remedies it may have, self-perform (through its own forces or through other contractors) the necessary corrective action(s) and deduct all amounts so incurred from any amount then or thereafter due Contractor.

2.6 **Contractor's Warranty.**

- 2.6.1 Contractor warrants to UTA that all Work, including all materials and equipment furnished as part of the Work, shall be: (i) of good quality conforming to generally recognized industry standards; (ii) in conformance with the Contract Documents; (iii) free of defects in materials and workmanship; and (iv) consistent with applicable Legal Requirements. Without limiting the generality of the forgoing, Contractor also specifically warrants that any design, engineering or other professional services provided by Contractor shall be shall

satisfy applicable professional standards of care and that all materials and that any equipment furnished as part of the construction shall be new (unless otherwise specified in the Contract Documents). This provision is not intended to limit any manufacturer's warranty that provides UTA with greater warranty rights than set forth in this Section 2.6. Contractor shall provide UTA with all manufacturers' warranties upon Substantial Completion. Similarly, nothing in this Article is intended to limit any other express warranties set forth in the Contract Documents or to limit any other warranties implied by law, custom or usage of trade.

- 2.6.2 If Contractor becomes aware of any defect in the Work, or non-conformance with the Contract Documents, Contractor shall give prompt written notice of that defect or non-conformance to UTA.
- 2.6.3 Except as otherwise stated in the Agreement, Contractor shall correct any Work that does not comply with the warranties provided above for a period of two years following the date of Substantial Completion.
- 2.6.4 Contractor shall, within seven (7) Days of receipt of written notice from UTA that the Work does not comply with the warranties provided above, take meaningful steps to commence corrective action, including the correction, removal, replacement or re-performance of the nonconforming Work and the repair of any damage to other property caused the warranty failure. If Contractor fails to commence the necessary corrective action within such seven (7) Day period (or thereafter fails to continuously and diligently pursue such corrective action to completion), UTA may (in addition to any other remedies provided under the Contract Documents) provide Contractor with written notice that UTA will self-perform (through its own forces or through other contractors) correction of the warranty failure at Contractor's expense. If UTA performs (or causes to be performed) such corrective action, UTA may collect from Contractor all amounts so incurred. If the nonconforming Work creates an emergency requiring an immediate response, the seven (7) Day period identified above shall be deemed inapplicable.
- 2.6.5 The two-year period referenced in Section 2.6.3 above only applies to Contractor's obligation to correct nonconforming Work and is not intended to constitute a period of limitations for any other rights or remedies UTA may have regarding Contractor's other obligations under the Contract Documents

ARTICLE 3 **Site Conditions**

3.1 Hazardous Materials.

- 3.1.1 Unless otherwise expressly provided in the Contract Documents to be part of the Contractor's Work, Contractor is not responsible for any Hazardous Materials encountered at the Site. "Hazardous Materials" means any substance that: (i) is deemed a hazardous waste or substance under any environmental law; or (ii) might endanger the health of people exposed to it.

- 3.1.2 If Contractor discovers at the Site any substance the Contractor reasonably believes to be a Hazardous Material, Contractor shall immediately stop Work in the area of the discovery and immediately report the discovery to the UTA Project Manager. UTA shall determine how to deal with the Hazardous Material, and Contractor shall resume Work in the area when directed to do so by the UTA Project Manager.
- 3.1.3 Contractor will be entitled to an adjustment to the Contract Price and/or Contract Time(s) to the extent Contractor's cost and/or time of performance have been adversely impacted by the presence of Hazardous Materials.
- 3.1.4 The risk allocation and change provisions of Sections 3.1.1 through 3.1.3 do not apply to any Hazardous Materials introduced to the Site by Contractor, its Subcontractors, or anyone for whose acts Contractor is responsible. Those provisions also exclude Hazardous Materials that were properly stored and/or contained at the Site but thereafter released as a result of the Contractor's negligent performance of the Work. To the extent that Hazardous Materials are introduced and/or released at the Site by Contractor as described above in this Section 3.1.4, then: (i) to the fullest extent permitted by law, Contractor shall defend and indemnify UTA from and against all claims, losses, damages, liabilities and expenses, including attorneys' fees and expenses, arising out of or resulting from such Hazardous Materials; and (ii) Contractor shall not be entitled to an extension of Contract Price and/or Contract Time(s).

3.2 Differing Site Conditions.

- 3.2.1 If Contractor encounters a Differing Site Condition, Contractor will be entitled to an adjustment to the Contract Price and/or Contract Time(s) to the extent Contractor's cost and/or time of performance have been adversely impacted by the Differing Site Condition. "Differing Site Condition" means concealed or latent physical conditions at the Site that: (i) materially differ from the conditions indicated in the Contract Documents; and (ii) are of an unusual nature, differing materially from the conditions ordinarily encountered and generally recognized as inherent in the Work.
- 3.2.2 Upon encountering a Differing Site Condition, Contractor shall provide prompt written notice to UTA of such condition, which notice shall not be later than five (5) Days after such condition has been encountered. Contractor shall, to the extent reasonably possible, provide such notice before the Differing Site Condition has been substantially disturbed or altered.

ARTICLE 4
Payment

4.1 Schedule of Values.

- 4.1.1 Unless required by UTA upon execution of this Agreement, within ten (10) Days of execution of the Agreement, Contractor shall submit for UTA's review and approval a

Schedule of Values for all of the Work. The Schedule of Values will: (i) subdivide the Work into its respective parts; (ii) include values for all items comprising the Work; and (iii) serve as the basis for monthly progress payments made to Contractor throughout the Work.

4.1.2 UTA will timely review and approve the Schedule of Values so as not to delay the submission of the Contractor's first application for payment. UTA and Contractor shall timely resolve any differences so as not to delay the Contractor's submission of its first application for payment.

4.2 Application for Payment.

4.2.1 To receive payment, Contractor shall submit to UTA an Application for Payment requesting payment for all Work performed as of the date of the Application for Payment. Contractor shall not submit Applications for Payment more often than once per month. The Application for Payment must be accompanied by supporting documentation sufficient to establish, to UTA's reasonable satisfaction, Contractor's entitlement to receive payment.

4.2.2 The Application for Payment may request payment for equipment and materials not yet incorporated into the Project, provided that: (i) UTA is satisfied that the equipment and materials are suitably stored at either the Site or another acceptable location; (ii) the equipment and materials are protected by suitable insurance; and (iii) upon payment, UTA will receive the equipment and materials free and clear of all liens and encumbrances.

4.2.3 The Application for Payment will constitute Contractor's representation that the Work described therein has been performed consistent with the Contract Documents, has progressed to the point indicated in the Application for Payment, and that title to all materials and equipment will pass to UTA free and clear of all claims, liens, encumbrances, and security interests upon the incorporation of the materials and equipment into the Project, or upon Contractor's receipt of payment, whichever occurs earlier.

4.3 Sales Tax Exemption

4.3.1 Purchases of certain materials are exempt from Utah sales tax. UTA will provide a sales tax exemption certificate to Contractor upon request. UTA will not pay Contractor for sales taxes for exempt purchases, and such taxes should not be included in Contractor's Application for Payment.

4.4 UTA's Payment Obligations.

4.4.1 UTA shall pay Contractor all amounts properly requested and documented within thirty (30) Days of receipt of an Application for Payment.

4.4.2 Notwithstanding Section 4.4.1, UTA may withhold up to 5% of each payment as retention in accordance with Utah Code Ann. § 13-8-5.

4.4.3 Notwithstanding Section 4.4.1, UTA may offset from such Application for Payment amounts any owed to UTA by Contractor pursuant to the Contract Documents.

4.4.4 If UTA determines that Contractor is not entitled to all or part of an Application for Payment as a result of Contractor's failure to meet its obligations under the Contract Documents, UTA will notify Contractor of the specific amounts UTA has withheld (or intends to withhold), the reasons and contractual basis for the withholding, and the specific actions Contractor must take to qualify for payment under the Contract Documents. If the Contractor disputes UTA's bases for withholding, Contractor may pursue its rights under the Contract Documents, including those under Article 8.

4.5 **Contractor's Payment Obligations.**

4.5.1 Contractor shall pay Subcontractors, in accordance with its contractual obligations to such parties, all the amounts Contractor has received from UTA on account of their work. Contractor shall indemnify and defend UTA against any claims for payment and mechanic's liens as set forth in Section 5.2 hereof.

4.5.2 If the Contract Documents include Federal Clauses, the terms of those Federal Clauses pertaining to payment of Subcontractors supersede any conflicting terms of this Article 4.

4.6 **Substantial Completion.**

4.6.1 Contractor shall notify UTA when it believes the entire Work is Substantially Complete. As used in the Contract Documents, "Substantially Complete" or "Substantial Completion" refers to the Contractor's satisfactory completion of all Work in accordance with the Contract Documents (excluding Punchlist items) to point such that UTA may safely start-up, occupy or otherwise fully use the Project for its intended purposes in compliance with applicable Legal Requirements. The terms "Substantially Complete" or "Substantial Completion" also require the completion of any items of Work specifically set forth as conditions precedent to Substantial Completion in the Agreement. Within five (5) Days of UTA's receipt of Contractor's notice, UTA and Contractor will jointly inspect such Work to verify that it is Substantially Complete in accordance with the requirements of the Contract Documents. If such Work is Substantially Complete, UTA shall prepare and issue a Certificate of Substantial Completion that will set forth: (i) the date of Substantial Completion of the Work or portion thereof; (ii) the remaining Punchlist items that have to be completed before Final Completion and final payment; and (iii) provisions (to the extent not already provided in the Contract Documents) establishing UTA's and Contractor's responsibility for the Project's security, maintenance, utilities and insurance pending Final Completion and final payment.

4.6.2 Promptly after issuing the Certificate of Substantial Completion, UTA shall release to Contractor all retained amounts, less an amount equal to two times the reasonable value of all remaining Punchlist items noted in the Certificate of Substantial Completion.

- 4.6.3 Upon Contractor's request or upon UTA's own initiative, UTA may, in its sole discretion, deem a discrete segment of the Project to be Substantially Complete. The provisions of Sections 4.6.1 and 4.6.2 will apply to that discrete segment of the Project. In addition, before UTA may take possession of a discrete segment of the Project, UTA and Contractor shall obtain the consent of their sureties, insurers, and any government authorities having jurisdiction over the Project.
- 4.6.4 Following Substantial Completion, UTA may restrict Contractor's access to the Site. UTA shall allow Contractor reasonable access to the Site in order for the Contractor to achieve Final Completion.

4.7 **Final Payment.**

- 4.7.1 When Contractor has achieved Final Completion of the Work, Contractor shall submit a Final Application for Payment. As used in the Contract Documents, "Final Completion" refers to the Contractor's satisfactory completion of all Work in accordance with the Contract Documents including completion of Punchlist items, demobilization from the Site and the transmittal of all deliverables required by the Contract Documents. The Final Application for Payment shall include (at a minimum) the items set forth below.
 - 4.7.1.1 An affidavit that there are no claims, obligations or liens outstanding or unsatisfied for labor, services, materials, equipment, taxes or other items performed, furnished or incurred for or in connection with the Work which will in any way affect UTA's interests;
 - 4.7.1.2 A general release executed by Contractor waiving, upon receipt of final payment, all claims, except those claims previously made in writing to UTA and remaining unsettled at the time of final payment;
 - 4.7.1.3 All as-built drawings, redlined drawings, operating manuals, warranty assignments and other deliverables required by the Contract Documents; and
 - 4.7.1.4 Certificates of insurance confirming that required coverages will remain in effect consistent with the requirements of the Contract Documents.
- 4.7.2 Deficiencies in the Work discovered after Substantial Completion, whether or not such deficiencies would have been included on the Punchlist if discovered earlier, will be deemed warranty Work. Contractor shall correct such deficiencies pursuant to Section 2.6, and UTA may withhold from the final payment the reasonable value of completion of the deficient work until that work is completed.

ARTICLE 5 **Indemnification and Loss**

- 5.1 **Patent and Copyright Infringement.** If the Work includes any design services, provisions 5.1.1 through 5.1.3 apply.

5.1.1 Contractor shall defend any action or proceeding brought against UTA based on any claim that the Work, or any part thereof, or the operation or use of the Work or any part thereof, constitutes infringement of any United States patent or copyright, now or hereafter issued. UTA shall give prompt written notice to Contractor of any such action or proceeding and will reasonably provide authority, information and assistance in the defense of same. Contractor shall indemnify UTA from and against all damages and costs, including but not limited to attorneys' fees and expenses awarded against UTA or Contractor in any such action or proceeding. Contractor shall keep UTA informed of all developments in the defense of such actions.

5.1.2 If UTA is enjoined from the operation or use of the Work, or any part thereof, as the result of any patent or copyright suit, claim, or proceeding, Contractor shall at its sole expense take reasonable steps to procure the right to operate or use the Work. If Contractor cannot so procure such right within a reasonable time, Contractor shall promptly, at Contractor's expense, either: (i) modify the Work so as to avoid infringement of any such patent or copyright; or (ii) replace said Work with Work that does not infringe or violate any such patent or copyright.

5.1.3 Sections 5.1.1 and 5.1.2 above shall not be applicable to any suit, claim or proceeding based on infringement or violation of a patent or copyright: (i) relating solely to a particular process or product of a particular manufacturer specified by UTA and not offered or recommended by Contractor to UTA; or (ii) arising from modifications to the Work by UTA or its agents after acceptance of the Work

5.2 **Payment Claim Indemnification.** Provided that UTA is not in breach of its contractual obligation to make payments to Contractor for the Work, Contractor shall indemnify, defend and hold harmless UTA from any claims or mechanic's liens brought against UTA or against the Project as a result of the failure of Contractor, its Subcontractors, or others for whose acts Contractor is responsible, to pay for any services, materials, labor, equipment, taxes or other items or obligations furnished or incurred for or in connection with the Work. Within three (3) Days of receiving written notice from UTA that such a claim or mechanic's lien has been filed, Contractor shall commence to take the steps necessary to discharge said claim or lien, including, if necessary, the furnishing of a mechanic's lien bond. If Contractor fails to do so, UTA will have the right to discharge the claim or lien and hold Contractor liable for costs and expenses incurred, including attorneys' fees.

5.3 **Contractor's General Indemnification.**

5.3.1 Contractor, to the fullest extent permitted by law, shall indemnify, hold harmless and defend UTA, its officers, trustees, and employees from and against claims, losses, damages, liabilities, including attorneys' fees and expenses, for bodily injury, sickness or death, and property damage or destruction resulting from or arising out of the negligent acts or omissions of Contractor, Subcontractors, anyone employed directly or indirectly by any of them or anyone for whose acts any of them may be liable.

5.3.2 If an employee of Contractor, a Subcontractor, anyone employed directly or indirectly by any of them or anyone for whose acts any of them may be liable has a claim against UTA, its officers, directors, employees, or agents, Contractor's indemnity obligation set forth in Section 5.3.1 above will not be limited by any limitation on the amount of damages, compensation or benefits payable by or for Contractor, Subcontractors, or other entity under any employee benefit acts, including workers' compensation or disability acts.

5.4 **Risk of Loss.** Contractor bears all risk of loss to the Project, including materials and equipment not yet incorporated into the Project, until final payment is made by UTA.

ARTICLE 6

Time

6.1 **Obligation to Achieve the Contract Times.** Contractor shall commence performance of the Work and achieve the Contract Time(s) in accordance with the Contract Documents. The Contract Documents specify critical completion milestones with which Contractor must comply. All time and schedule requirements included within the Contract Documents are of the essence. By executing the Agreement, Contractor confirms that the completion milestones in the Contract Documents are reasonable for the performance of the Work. Unless otherwise excused by the terms of the Contract Documents, Contractor's failure to timely perform the Work in accordance with the completion milestones shall result in the assessment of liquidated damages (if, and to the extent, set forth in the Agreement) and (where no liquidated damages are provided under the Agreement or where the maximum liquidated damages available under the Agreement have been incurred) an event of default.

6.2 **Excusable Delays.** The Contract Time(s) for performance shall be equitably adjusted by Change Order to the extent that Contractor is actually and demonstrably delayed in the performance of the Work because of: (i) Differing Site Conditions (as provided in Section 3.2); (ii) Hazardous Materials (as provided in Section 3.1); (iii) Force Majeure Events (as defined in Section 1.3); (iv) changes in the Work directed by UTA (as provided in Section 7.2); (v) constructive changes (as provided in Section 7.3); (vi) changes in Legal Requirements (as provided in Section 2.3.3); (viii) a suspension without cause (as provided in Section 9.1); or (viii) UTA's unexcused delay in performing any UTA obligation specified in the Contract Documents in accordance with the completion milestones indicated in the approved schedule.

6.3 **Excusable and Compensable Delays.** In addition to Contractor's right to a time extension for those events set forth in Section 6.2 above, Contractor will also be entitled to an appropriate adjustment of the Contract Price provided, ~~however, that the Contract Price will not be adjusted for delays caused by Force Majeure Events.~~

ARTICLE 7 Changes

7.1 **Change Orders.**

7.1.1 Contractor shall not undertake any activity that materially changes the Work, or materially deviates from the requirements of the Contract Documents, except as authorized in this Article 7. Any costs incurred by Contractor without authorization as provided in this Article 7 will be considered non-compensable.

7.1.2 A Change Order is a written instrument, signed by UTA and Contractor, issued after execution of the Agreement, stating their agreement on a change in: (i) the scope of the Work; (ii) the Contract Price; and/or (iii) the Contract Time(s).

7.1.3 All changes in the Work authorized by applicable Change Order shall be performed under the applicable conditions of the Contract Documents. UTA and Contractor shall negotiate in good faith and as expeditiously as possible the appropriate adjustments for such changes.

7.2 **UTA-Directed Changes.** UTA may direct changes in the Work. Upon receipt of such direction, Contractor shall prepare an estimate of the cost and schedule impact of the change (if any). Upon agreement between UTA and Contractor on the scope of the change to the Work, and the adjustment, if any, to the Contract Price and/or Contract Times, UTA and Contractor shall execute a written Change Order.

7.3 **Constructive Changes.**

7.3.1 To the extent that Contractor: (i) receives a written or verbal direction or proceeding from UTA that Contractor believes to constitute a material change to the nature, character or schedule of the Work; and/or (ii) becomes aware of any circumstance or condition that expressly provides Contractor a right to a Change Order under the terms of the Contract Documents, then (in either case) Contractor shall deliver to UTA's Project Manager written notice (hereinafter a "Potential Change Notice") within ten (10) Days after Contractor becomes aware of (or should have reasonably become aware) the facts and circumstances which Contractor believes to give rise to a Change Order.

7.3.2 Contractor's failure to deliver a Potential Change Notice in a timely manner shall constitute a waiver of all of Contractor's rights to a Change Order.

7.3.3 In conjunction with the Potential Change Notice (or as soon as reasonably possible thereafter), Contractor shall submit to UTA all supporting information and documentation necessary for UTA to evaluate the contractual basis for the Potential Change Notice and to also evaluate the relief claimed by Contractor. Contractor shall promptly respond to all UTA inquiries about the Potential Change Notice and the supporting information and documentation.

7.3.4 To the extent UTA concludes that the Potential Change Notice demonstrates Contractor's entitlement to a Contract adjustment, and provided that the parties are able to negotiate

mutually agreeable adjustments to the Contract Documents, then UTA and Contractor shall execute a written Change Order.

7.4 Direction or Authorization to Proceed.

7.4.1 Prior to final agreement with respect to a Change Order, UTA may issue a Direction or Authorization to Proceed (“DAP”). A DAP is a written order unilaterally prepared and signed by UTA directing the Contractor to proceed with specified Work while Change Order negotiations or Claim resolution discussions continue. UTA may issue a DAP at any time, and Contractor shall undertake the Work as set forth in the DAP, and in accordance with the Contract Documents.

7.4.2 After issuance of a DAP, UTA and Contractor shall continue to negotiate in good faith to resolve outstanding issues expeditiously.

7.5 Requests for Information. UTA shall have the right, from time to time, to issue clarifications to the Work of a non-material nature at any time. Contractor shall have the corresponding right to seek clarification with respect to ambiguous or conflicting provisions of the Contract Documents. Such clarifications or conflicts shall be confirmed, implemented and documented through a Request for Information (“RFI”) process to be developed for the Project. The RFI process may also be used to document minor changes in the Work do not involve an adjustment in the Contract Price and/or Contract Time(s) and do not materially and adversely affect the Work, including the design, quality, performance and workmanship required by the Contract Documents.

7.6 Contract Price Adjustments.

7.6.1 The increase or decrease in Contract Price resulting from a change in the Work will be determined by one or more of the following methods:

7.6.1.1 Unit prices set forth in the Agreement or as subsequently agreed to between the parties;

7.6.1.2 A mutually accepted lump sum, properly itemized and supported by sufficient substantiating data to permit evaluation by UTA;

7.6.1.3 Costs, fees and any other markup rates set forth in the Agreement; or

7.6.1.4 If an increase or decrease cannot be agreed to as set forth in items 7.6.1.1 through 7.6.1.3 above and UTA issues a DAP, the cost of the change of the Work shall be determined by the reasonable expense and savings in the performance of the Work resulting from the change, including a reasonable overhead and profit rate, as may be set forth in the Agreement.

7.6.2 If unit prices are set forth in the Contract Documents or are subsequently agreed to by the parties, but application of such unit prices will cause substantial inequity to UTA or Contractor because of differences in the character or quantity of such unit items as

or change

or cost

originally contemplated, such unit prices shall be equitably adjusted.

7.6.3 Negotiations over changes in the Contract Price will be conducted using an open-book cost-estimating process. UTA defines “open-book” to include all elements of Contractor’s costs, including labor hours and rates, units and estimated quantities, unit prices, equipment estimates, material costs, and subcontractor costs. Contractor shall openly share its detailed cost estimate, material and subcontractor quotations and any other information used to compile its cost estimate.

7.7 **Disputes Regarding Change Orders.** If the parties are not able to agree as to whether a Change Order is warranted under the Contract Documents, or cannot agree upon the extent of relief to be granted under a Change Order after good faith negotiations, either party may refer the dispute to the Claim resolution provisions of Article 8. Pending resolution of such Claim, Contractor shall proceed with the Work as directed by UTA under a reservation of rights. UTA shall continue to pay any undisputed payments related to such Claim.

7.8 **Emergencies.** In any emergency affecting the safety of persons and/or property, Contractor shall act, at its discretion, to prevent threatened damage, injury or loss. Any change in the Contract Price and/or Contract Time(s) on account of emergency work shall be determined as provided in this Article 7.

ARTICLE 8 Claims and Claim Resolution

8.1 Claims.

8.1.1 “Claim” means any disputes between UTA and the Contractor arising out of or relating to the Contract Documents including any disputed claims for Contract adjustments that cannot be resolved in accordance with the Change Order negotiation process set forth in Article 8. Claims must be made by written notice. The responsibility to substantiate claims rests with the party making the claim.

8.1.2 Unless otherwise directed by UTA in writing, Contractor shall proceed diligently with performance of the Work pending final resolution of a Claim, including litigation. UTA shall continue to pay any undisputed payments related to such Claim.

8.2 Claim Resolution.

8.2.1 The parties shall attempt in good faith to resolve promptly through negotiation any Claim arising out of or relating to the Contract Documents. If a Claim should arise, UTA’s Project Manager and Contractor’s Project Manager will meet at least once to attempt to resolve the Claim. For such purpose, either may request the other to meet within seven (7) Days of the date the Claim is made, at a mutually agreed upon time and place.

8.2.2 If UTA’s Project Manager and Contractor’s Project Manager are not able to resolve the Claim within fourteen (14) Days after their first meeting (or such longer period of time as may be mutually agreed upon), either party may request that UTA’s Senior Representative

and the Contractor's management representative ("Contractor's Management Representative") meet at least once to attempt to resolve the Claim.

- 8.2.3 If the Claim has not been resolved within sixty (60) Days of the date the Claim is made, either party may refer the Claim to non-binding mediation by sending a written mediation request to the other party. In the event that such a request is made, the Parties agree to participate in the mediation process. Non-binding mediation of claims or controversies under the Contract Documents shall be conducted by a professional mediator that is mutually acceptable to and agreed upon by both parties (the "Mediator"). The parties and the Mediator may join in the mediation any other party necessary for a mutually acceptable resolution of the Claim. The mediation procedure shall be determined by the Mediator in consultation with the parties. The fees and expenses of the Mediator shall be borne equally by the parties.
- 8.2.4 If the Claim is not resolved within thirty (30) days after the commencement of mediation, or if no mediation has been commenced within one hundred and twenty (120) days of the date the Claim is made, either party may commence litigation to resolve the Claim. The exclusive forum for any such litigation is the Third District Court in and for Salt Lake County, Utah.

ARTICLE 9 **Suspension and Termination**

9.1 UTA's Right to Stop Work.

- 9.1.1 UTA may, without cause and for its convenience, order Contractor in writing to stop and suspend the Work. Such suspension shall not exceed one hundred and twenty (120) consecutive Days or aggregate more than two hundred and forty (240) Days during the duration of the Project. In the event a suspension continues longer than the above-referenced periods, Contractor shall have the right to terminate the Agreement. Any such termination shall be considered to be a termination for convenience by UTA.
- 9.1.2 If a suspension is directed by UTA without cause, Contractor shall be entitled to seek an adjustment of the Contract Price and/or Contract Time(s) if its cost or time to perform the Work has been adversely impacted by any suspension or stoppage of the Work by UTA.
- 9.1.3 In addition to its rights under Section 9.3, UTA shall have the right to order a suspension for cause if the Work at any time ceases to comply with the workmanship, safety, quality or other requirements of the Contract Documents or any Legal Requirements. Contractor shall not be entitled to seek an adjustment the Contract Price and/or Contract Time(s) with regard to any such suspension.

9.2 UTA's Right to Terminate for Convenience. Upon written notice to Contractor, UTA may, for its convenience and without cause, elect to terminate this Agreement. In such event, UTA shall pay Contractor for the following:

- 9.2.1 All Work satisfactorily completed or commenced and in process as of the effective date of termination;
- 9.2.2 The reasonable and demonstrable costs and expenses attributable to such termination, including demobilization costs and amounts due in settlement of terminated contracts with Subcontractors; and
- 9.2.3 The fair and reasonable sums for overhead and profit on the sum of items 9.2.1.1 and 9.2.1.2 above. UTA shall not be liable for anticipated profits, costs or overhead based upon Work not yet performed as of the date of termination.

9.3 UTA's Right to Terminate for Cause; Other Remedies for Default.

- 9.3.1 Subject to the cure provision of Section 9.3.2 below and other limitations set forth in these General Conditions, Contractor shall be in default of its obligations under the Contract Documents if Contractor: (i) fails to provide a sufficient number of skilled workers; (ii) fails to supply the materials required by the Contract Documents; (iii) fails to comply with applicable Legal Requirements; (iv) fails to timely pay its Subcontractors without proper cause; (v) makes a materially false or misleading representation or certification in conjunction with the Contract Documents; (vi) fails to prosecute the Work with promptness and diligence to ensure that the Work is completed by the Contract Time(s), as such times may be adjusted; (vii) fails to satisfy any guaranteed interim or completion milestone set forth in the Contract Documents; or (viii) fails to perform any other material obligations under the Contract Documents. In any such event, UTA (in addition to any other rights and remedies provided in the Contract Documents or by law) shall have the rights set forth in Sections 9.3.2 through 9.3.5 below.
- 9.3.2 Upon the occurrence of an event of default set forth in Section 9.3.1 above, UTA may provide written notice to Contractor that it intends to terminate the Agreement (in whole or in part) or pursue other available remedies unless the grounds for default are cured within ten (10) Days of Contractor's receipt of such notice. If Contractor fails to cure the grounds for default within such period, then UTA may declare the Agreement, or portions of the Agreement, terminated for default by providing written notice to Contractor of such declaration; provided, however, that to the extent that an item included is the notice of default and demand for cure is capable of cure, but not within the ten-Day cure period, then the Agreement shall not be terminated so long as Contractor commences actions to reasonably cure such breach within the 10-Day cure period and thereafter continuously and diligently proceeds with such curative actions until completion (such additional period not to exceed 45 Days). UTA may terminate the Agreement without opportunity to cure if the breach involves the Contractor's material failure to comply with any Legal Requirements pertaining to safety or environmental compliance.
- 9.3.3 Upon the continuance of a breach described in Section 9.3.1 for more than ten (10) Days following delivery of written notice to Contractor (and regardless of whether the Agreement, or any portion hereof, has been terminated as provided above), UTA shall be entitled to self-perform (through its own forces or through other contractors) the corrective

action necessary to cure Contractor's event of default and deduct all costs so incurred from any amount then or thereafter due to Contractor.

9.3.4 Upon the continuance of a breach described in Section 9.3.1 for more than ten (10) Days following delivery of written notice to Contractor (and regardless of whether the Agreement, or any portion hereof, has been terminated as provided above), UTA shall be entitled to seek performance by any guarantor of Contractor's obligations hereunder or draw upon any surety or security provided for in the Contract Documents.

9.3.5 Upon declaring the Agreement terminated pursuant to Section 9.3.2 above, UTA may enter upon the premises and take possession, for the purpose of completing the Work, of all materials, ~~equipment~~, scaffolds, ~~tools~~, ~~appliances~~ and other items thereon, which have been purchased or provided for the performance of the Work, all of which Contractor hereby transfers, assigns and sets over to UTA for such purpose, and to employ any person or persons to complete the Work and provide all of the required labor, services, materials, equipment and other items. In the event of such termination, Contractor shall not be entitled to receive any further payments under the Contract Documents until the Work shall be finally completed in accordance with the Contract Documents. At such time, if the unpaid balance of the Contract Price exceeds the cost and expense incurred by UTA in completing the Work, such excess shall be paid by UTA to Contractor. If UTA's cost and expense of completing the Work exceeds the unpaid balance of the Contract Price, then Contractor shall pay the difference to UTA. Such costs and expenses include not only the cost of completing the Work, but also losses, damages, costs and expenses, including attorneys' fees and expenses, incurred by UTA in connection with the procurement and defense of claims arising from Contractor's default.

9.3.6 All rights and remedies set forth in the Contract Documents are cumulative, and unless otherwise specifically provided in the Contract Documents are not exclusive of any other rights or remedies that may be available, whether provided by law, equity, statute, in any other agreement between the Parties or otherwise. Upon the occurrence of any such default, following the applicable process described in this Article, UTA shall be entitled to pursue any and all other rights and remedies, including without limitation damages, that UTA may have against Contractor under the Contract Documents or at law or in equity.

9.3.7 If UTA improperly terminates the Agreement for cause, the termination for cause will be converted to a termination for convenience in accordance with the provisions of Section 9.2 above.

9.4 **Bankruptcy of Contractor.**

9.4.1 If Contractor institutes or has instituted against it a case under the United States Bankruptcy Code, such event may impair or frustrate the Contractor's ability to perform its obligations under the Contract Documents. Accordingly, should such event occur:

9.4.1.1 Contractor, its trustee or other successor, shall furnish, upon request of UTA, adequate assurance of the ability of the Contractor to perform all future material obligations under

the Contract Documents, which assurances shall be provided within ten (10) Days after receiving notice of the request; and

9.4.1.2 Contractor shall file an appropriate action within the bankruptcy court to seek assumption or rejection of the Agreement within sixty (60) Days of the institution of the bankruptcy filing and shall diligently prosecute such action. If Contractor fails to comply with its foregoing obligations, UTA shall be entitled to request the bankruptcy court to reject the Agreement, declare the Agreement terminated and pursue any other recourse available to the UTA under this Article 9.

9.4.2 The rights and remedies under Section 9.4.1 above shall not be deemed to limit the ability of UTA to seek any other rights and remedies provided by the Contract Documents or by law, including its ability to seek relief from any automatic stays under the United States Bankruptcy Code.

ARTICLE 10 **Value Engineering**

10.1 Value Engineering Change Proposals.

10.1.1 A Value Engineering Change Proposal (“VECP”) is a proposal developed, prepared, and submitted to UTA by the Contractor, which reduces the cost of the Work without impairing essential functions or characteristics of the Project, as determined by UTA in its sole discretion. UTA encourages Contractor to submit VECPs whenever it identifies potential savings or improvements. UTA may also request the Contractor to develop and submit a specific VECP.

10.1.2 In determining whether a VECP will impair essential functions or characteristics of the Project, UTA may consider: (i) relative service life; (ii) maintenance effort and frequency; (iii) environmental and aesthetic impacts; (iv) system service; (v) effect of other system components; and (vi) other issues as UTA deems relevant. A VECP must not be based solely on a change in quantities.

10.1.3 Contractor must include the following information in any VECP:

10.1.3.1 A narrative description of the proposed change,

10.1.3.2 A discussion of differences between existing requirements and the proposed change, together with advantages and disadvantages of each changed item;

10.1.3.3 A complete cost analysis, including the cost estimate of any additional rights-of-way or easements required for implementation of the VECP;

10.1.3.4 Justification for changes in function or characteristics of each item and effect of the change on the performance on the end item;

10.1.3.5 A description of any previous use or testing of the proposed approach and the conditions and results. If the VECP was previously submitted on another UTA

project, the Contractor shall indicate the date, contract number, and the action taken by UTA;

10.1.3.6 Costs of development and implementation; and

10.1.3.7 Any additional information requested by UTA, which must be provided in a timely manner.

10.2 Review and Approval of VECPs

10.2.1 Upon receipt of a VECP, UTA shall process it expeditiously, but will not be liable for any delay in acting upon any VECP. Contractor may withdraw all or part of any VECP at any time prior to approval by UTA, but shall, in any case, be liable for costs incurred by UTA in reviewing the withdrawn VECP, or part thereof. In all other situations, each party will bear its own costs in connection with preparation and review of VECPs.

10.2.2 UTA may approve in whole or in part any VECP submitted. The decision of UTA regarding rejection or approval of any VECP will be at the sole discretion of UTA and will be final and not subject to appeal. Contractor will have no claim for any additional costs or delays resulting from the rejection of a VECP, including development costs, loss of anticipated profits, or increased material or labor costs

10.3 **Cost Savings.** Except as otherwise stated in the Agreement, any savings resulting from an approved VECP will accrue to the benefit of UTA and Contractor on a 50/50 cost sharing basis.

10.4 **Ownership of VECPs.** All approved or disapproved VECPs will become the property of UTA and must contain no restrictions imposed by Contractor on their use or disclosure. UTA retains the right to use, duplicate, and disclose, in whole or in part, any data necessary for the utilization of the VECP on any other projects without any obligation to Contractor. This provision is not intended to deny rights provided by law with respect to patented materials or processes.

ARTICLE 11 Health Insurance

11.1 Insurance Coverage for Employees.

11.1.1 If the Contract Price is \$2,000,000 or more, Contractor shall, prior to the effective date of the Agreement, demonstrate to UTA that Contractor has and will maintain an offer of qualified health insurance coverage (as defined by Utah Code Ann. § 17B-2a-818.5) for the Contractor's employees and the employee's dependents during the duration of the Contract.

11.2.1 If the Contractor enters into any subcontracts under the Contract Documents in an amount of \$1,000,000 or more, then Contractor shall also demonstrate to UTA that such subcontractor(s) have and will maintain an offer of qualified health insurance coverage for the subcontractor's employees and the employee's dependents during the duration of the subcontract

ARTICLE 12
Miscellaneous

- 12.1 **Confidential Information.** “Confidential Information” means information that is determined by the transmitting party to be of a confidential or proprietary nature and: (i) the transmitting party identifies in writing as either confidential or proprietary; (ii) the transmitting party takes steps to maintain the confidential or proprietary nature of the information; and (iii) the document is not otherwise available in or considered to be in the public domain. To the extent permitted by law (including specifically UCA Title 63G Chapter 2), the receiving party shall maintain the confidentiality of the Confidential Information and shall use the Confidential Information solely in connection with the Project. The parties agree that the Agreement itself (including all incorporated Contract Documents) does not constitute Confidential Information.
- 12.2 **PUBLIC INFORMATION:** Vendor acknowledges that the Contract and related materials (invoices, orders, etc.) will be public documents under the Utah Government Records Access and Management Act (GRAMA). Vendor’s response to the solicitation for the Contract will also be a public document subject to GRAMA, except for legitimate trade secrets, so long as such trade secrets were properly designated in accordance with terms of the solicitation.
- 12.3 **Prohibited Interest.** No member, officer, agent, or employee of UTA during his or her tenure or for one year thereafter shall have any interest, direct or indirect, including prospective employment by, Contractor or the proceeds under the Contract Documents without specific written authorization by UTA.
- 12.4 **Assignment.** Contractor acknowledges that the Work to be performed by Contractor is considered personal by UTA. Contractor shall not assign or transfer its interest in the Contract Documents without prior written approval by UTA.
- 12.5 **Successors.** Contractor and UTA intend that the provisions of the Contract Documents are binding upon the parties, their employees, agents, heirs, successors and permitted assigns.
- 12.6 **Governing Law.** The Agreement and all Contract Documents are governed by the laws of the State of Utah, without giving effect to its conflict of law principles. Actions to enforce the terms of this Agreement may only be brought in the Third District Court for Salt Lake County, Utah.
- 12.7 **Attorneys Fees and Costs.** If any party to this Agreement brings an action to enforce or defend its rights or obligations hereunder, the prevailing party shall be entitled to recover its costs and expenses, including mediation, arbitration, litigation, court costs and attorneys’ fees, if any, incurred in connection with such suit, including on appeal.
- 12.8 **Severability.** If any provision or any part of a provision of the Contract Documents is finally determined to be superseded, invalid, illegal, or otherwise unenforceable pursuant to any applicable Legal Requirements, such determination shall not impair or otherwise affect the validity, legality, or enforceability of the remaining provision or parts of the provision of the Contract Documents, which shall remain in full force and effect as if the unenforceable provision or part were deleted.

12.9 **No Waiver.** The failure of either Contractor or UTA to insist, in any one or more instances, on the performance of any of the obligations required by the other under the Contract Documents shall not be construed as a waiver or relinquishment of such obligation or right with respect to future performance.

12.10 **Headings.** The headings used in these General Conditions, or any other Contract Document, are for ease of reference only and shall not in any way be construed to limit or alter the meaning of any provision.

12.11 **Amendments.** The Contract Documents may not be changed, altered, or amended in any way except in writing signed by a duly authorized representative of each party.

12.12 **FORCE MAJEURE:** Neither party to the Contract will be held responsible for delay or default caused by fire, riot, acts of God and/or war which are beyond that party's reasonable control. UTA may terminate the Contract after determining such delay or default will reasonably prevent successful performance of the Contract.

Exhibit A Scope of Work

OVERVIEW

Contractor will install electronic signage with real-time digital electronic passenger information signs at several of our high-volume bus stops. This pilot project will include areas where buses and trains have collocated stops (Intermodal Hubs) in order to inform customers either transferring from trains to buses or arriving by some other means to the bus stop, when the next bus on a particular route departs.

In order to display the real-time bus departure information that will be developed in-house, UTA is asking for proposals to provide the installation of digital electronic passenger information signs (provided by others), fabrication and installation of steel signposts, networking equipment with NEMA enclosures, network and power cabling, and other construction and installation services.

The project consists of the construction and installation for twenty-three (23) real-time digital electronic passenger information signs (provided by others) at seven (7) bus hub locations. There will be seventeen (17) small signs six (6) large sign types. Locations and addresses of sign locations are located in Appendix A.

NETWORK EQUIPMENT

Contractor will use Cisco certified networking equipment and proposer must only propose Cisco certified networking equipment. The proposer will be responsible for providing all necessary equipment at each installation site including mounts, cabling, conduit, connectors, etc.

Contractor will provide network equipment and installation methods required to complete the installations.

WARRANTY AND GUARANTEE ON INSTALLATION AND EQUIPMENT

Contractor shall include the length and details of any warranty or guarantee on all construction and hardware and equipment installed. Digital signs are covered under separate warranties by others.

CONSTRUCTION AND INSTALLATION SERVICES

UTA will require comprehensive construction and installation services by qualified technicians. Subcontracting with vendors providing such services is permitted.

Construction and installation activities include (refer to project plans and specifications for more detailed information):

- Boring or digging trenches and installing conduit between sign location and network/power sources
- Fabrication of powder coated steel tube sign mounting poles (and associated mounting hardware)
- Installing signage poles into poured concrete footings
- Installing UTA provided digital signs on new sign poles and existing bus shelters
- Installing network equipment in NEMA enclosures
- Mounting NEMA enclosures at predetermined locations
- Patching concrete and/or asphalt
- Installing conduit and cabling
- Connecting equipment to power and network sources

The plan set includes overhead views of each site and construction details of where signs will be installed. The desired location of the sign installation and the existing network and power locations are shown. Locating and marking existing utilities will be the responsibility of the contractor. Any applicable as-built drawings in the project areas will be provided.

Contractor will complete the UTA TRAX & RWP Coordination through the source listed below:

<https://www.rideuta.com/Doing-Business/Property-Management>

Coordinate TRAX Access Permit, rail access insurance and construction activities with Owen Thompson, UTA Light Rail Operations Supervisor: 385-414-7795. All crew must be RWP trained prior to starting work (Class available online in the above link) and RWIC must be present during construction activities within 10' of nearest rail.

Contacts:

Project Management: Brandon Heath, 801-237-1915 or bheath@rideuta.com
Permits: Obtain TRAX Access Permit and Insurance

Exhibit B

Pricing and Payment Schedule

The Not to Exceed amount of this contract will be \$651,901.79. This includes the original amount listed below of \$617,558.00 on page 42 below, plus the additional amount from the updated scope below of \$34,343.79 on page 47 below.

Original Scope below before the detailed site visits between UTA and Skyline Electric.

**Real Time Bus Signage Construction and Installation
Cost Estimate**

				
Bus RTI Signage - Pricing Sheet				
	Unit	Quantity*	Unit Cost	Item Cost
Installation Items				
Contractor Mobilization, Permits, Traffic Control, Project Controls	LUMP	8	\$5,200.00	\$41,600
Sawcut	LF	846	\$4.75	\$4,019
Horizontal Conduit - Above Ground (2 @ 2", incl mounting equip)	LF	66	\$35.35	\$2,333
Horizontal Conduit - Buried (2 @ 2" dia sch 40 PVC, incl excavation, concrete, bedding, backfill, & compaction - 2' deep)	LF	2349	\$25.30	\$59,430
Vertical Conduit - Estimated (2 @ 2", incl mounting equip)	LF	30	\$47.06	\$1,412
Wire (3 - 12 AWG stranded 90° C copper wire, incl install through new or existing conduit)	LF	3225	\$2.50	\$8,063
Network Cable, incl install through new or existing conduit)	LF	7932	\$6.69	\$53,065
Concrete Patch (12" wide)	LF	416	\$47.00	\$19,552
Concrete Patch w/ color (12" wide)	LF	180	\$47.00	\$8,460
Concrete Patch @ curb & gutter	EA	13	\$150.00	\$1,950
Asphalt Patch (12" wide)	LF	0	\$0.00	\$0
Junction Box	EA	27	\$1,200.00	\$32,400
Panel Connection (Power & Network)	EA	14	\$3,900.00	\$54,600
Sign Connection (Power & Network)	EA	23	\$3,750.00	\$86,250
Sign Type A (Small) - install digital sign on post, see below for post & foundation items	EA	14	\$375.00	\$5,250
Sign Type B (Large) - install digital sign on post, see below for post & foundation items	EA	6	\$475.00	\$2,850
Shelter Mounted Sign Type A (Small) - install digital sign on bus shelter	EA	3	\$375.00	\$1,125
Landscape & Irrigation Repair	LUMP	5	\$1,500.00	\$7,500
Heat Cable Repair @ SL Central & Farmington (NO VENDOR QUOTE AVAILABLE. NO BID)	LUMP	0	\$0.00	\$0
Tyco refused to quote do to lack of information				
Post Fabrication Items**				
Steel Tubing 6"x6"x1/2"x20'	EA	20	810	\$16,200
Base plates, hand hole covers, nuts bolts, misc parts	EA	20	320	\$6,400
Cut Weld Labor	LUMP	20	1200	\$24,000
Powder Coating	LUMP	20	350	\$7,000
Mounting Brackets	EA	20	111	\$2,220
Install Post (half day 2 person crew)	LUMP	20	310	\$6,200
				\$0
Post Foundation Items**				
				\$0
Drill 6' deep 2' dia. shaft	EA	20	1050	\$21,000
Conduit	EA	20	130	\$2,600
Structural Concrete	EA	20	210	\$4,200
Misc parts - sono Tube, 2x4, bolt pattern	EA	20	1270	\$25,400
Form Labor	LUMP	20	280	\$5,600
Contractor Markup, Overhead, & Profit				\$73,290
Contractor Management Fee				\$33,590
Total Project Estimated Cost				\$617,558
*Contractor to confirm quantities				
** Post mounted signs are required at twenty (20) locations				

Payments will be made after the delivery and approval by UTA of the services completed. All services will be invoiced each month as ~~each area~~ ^{work} is completed.

Job ID: FY2021-0089



Project: UTA - 03456BM RTI Equipment Installation Budget

CO: 001: Scope Change

Summary Cost Codes Report

Vendor: Target

Labor Level: LABOR 1

7 Oct 2021 9:53:51

Cost Code 100, BRANCH			15.42% of Job Total				27.56% of Job Total			
Item #	Size	Description	Quantity	U/	Mat Unit	M-	Mat Result	Lab Unit	L-Fact	Lab Result
10002	1	GRC	160.00	FT	4.9053	1.000	784.85	0.0700	1.000	11.20
10181	1	CONDUIT CUT & THREAD	13.00	EA				0.4000	1.000	5.20
20131	1	GRC 90-DEG ELBOW	8.00	EA	16.0830	1.000	128.66	0.5000	1.000	4.00
20175	1	GRC FIELD BEND	12.00	EA				0.9000	1.000	10.80
30002	1	GRC COUPLING	15.00	EA	6.2894	1.000	94.34	0.2000	1.000	3.00
30344	1	GRC LB CONDUIT BODY	6.00	EA	17.1835	1.000	103.10	0.7500	1.000	4.50
40080	1	MYERS THREADED GRD HUB	4.00	EA	6.5902	1.000	26.36	1.2000	1.000	4.80
40133	1	LOCKNUT	16.00	EA	0.4523	1.000	7.24	0.2000	1.000	3.20
40219	1	GRD BUSHING INSULATED	8.00	EA	5.0188	1.000	40.15	0.3000	1.000	2.40
50075	1	LIQUIDTITE CONDUIT	42.00	FT	1.9210	1.000	80.68	0.0750	1.000	3.15
50086	1	LIQUIDTITE ANGLE CONNECTOR	4.00	EA	20.7914	1.000	83.17	0.2880	1.000	1.15
50097	1	LIQUIDTITE STRAIGHT CONNECTOR	6.00	EA	6.5197	1.000	39.12	0.2400	1.000	1.44
160706	1	GRC 1-HOLE MALLEABLE STRAP	10.00	EA	1.3166	1.000	13.17	0.0400	1.000	0.40
500130	1	ENCLOSURE HOLE PUNCH	8.00	EA				0.5600	1.000	4.48
630230	1	COND 1-PC NUT-BOLT STEEL STRUT CLAMP	17.00	EA	1.7462	1.000	29.69	0.0300	1.000	0.51

Cost Code 100, BRANCH totals: \$1,430.52

60.23

Cost Code 200, FEEDER			5.50% of Job Total				10.20% of Job Total			
Item #	Size	Description	Quantity	U/	Mat Unit	M-	Mat Result	Lab Unit	L-Fact	Lab Result
10005	2	GRC	4.00	FT	10.0876	1.000	40.35	0.1100	1.000	0.44
10062	2	PVC SCH 40	60.00	FT	3.0594	1.000	183.56	0.0800	1.000	4.80
10184	2	CONDUIT CUT & THREAD	2.00	EA				0.7000	1.000	1.40
20134	2	GRC 90-DEG ELBOW	2.00	EA	41.7465	1.000	83.49	1.0000	1.000	2.00
30005	2	GRC COUPLING	2.00	EA	14.5612	1.000	29.12	0.3000	1.000	0.60
30240	2	PVC COUPLING	6.00	EA	0.9020	1.000	5.41	0.3000	1.000	1.80
30289	2	PVC FEMALE ADAPTER	2.00	EA	1.2643	1.000	2.53	0.3000	1.000	0.60
30301	2	PVC END BELLS	2.00	EA	4.3839	1.000	8.77	0.2300	1.000	0.46
30347	2	GRC LB CONDUIT BODY	2.00	EA	63.1800	1.000	126.36	1.5000	1.000	3.00
40083	2	MYERS THREADED GRD HUB	2.00	EA	10.5760	1.000	21.15	1.6000	1.000	3.20
40234	2	GROUNDING BUSHING	2.00	EA	4.8176	1.000	9.64	0.6000	1.000	1.20

Summary Cost Codes: UTA - 03456BM RTI Equipment Installation Budget

7 Oct 2021 9:53:51

Cost Code 200, FEEDER totals: \$510.39 22.30

Cost Code 300, WIRE & TERMINATIONS 65.95% of Job Total 37.28% of Job Total

Item #	Size	Description	Quantity	U/	Mat Unit	M-	Mat Result	Lab Unit	L-Fact	Lab Result
70034	10	THHN/THWN CU (STR)	4,260.00	FT	0.4310	1.000	1,835.88	0.0070	1.000	29.82
70035	8	THHN/THWN CU (STR)	2,595.00	FT	0.8133	1.000	2,110.60	0.0090	1.000	23.36
70036	6.	THHN/THWN CU (STR)	1,671.00	FT	1.2512	1.000	2,090.81	0.0110	1.000	18.38
500090	2500#	MULE TAPE/HERCULINE PULL LINE	3,050.00	FT	0.0272	1.000	83.07	0.0026	1.000	7.93
500142	1/4	DRILL HOLE	16.00	EA	0.0000	1.000	0.00	0.1250	1.000	2.00

Cost Code 300, WIRE & TERMINATIONS totals: \$6,120.36 81.49

Cost Code 800, MISCELLANEOUS/OTHER 0.42% of Job Total 3.98% of Job Total

Item #	Size	Description	Quantity	U/	Mat Unit	M-	Mat Result	Lab Unit	L-Fact	Lab Result
40050	QUART	PVC (GLUE) CEMENT	1.00	EA	7.8986	1.000	7.90	0.2000	1.000	0.20
160089	1/4 x 3 1/4"	WEDGE ANCHOR	10.00	EA	1.3607	1.000	13.61	0.2000	1.000	2.00
160154	1/4"	FLAT WASHER (PLT)	10.00	EA	0.0365	1.000	0.37	0.0012	1.000	0.01
160163	1/4"	LOCK WASHER (PLT)	10.00	EA	0.0143	1.000	0.14	0.0012	1.000	0.01
160444	1/4 x 1 1/2"	LAG BOLT	10.00	EA	0.2098	1.000	2.10	0.1400	1.000	1.40
160468	3/8 x 1 1/2"	LAG BOLT	10.00	EA	0.3634	1.000	3.63	0.1500	1.000	1.50
160584	1/4 x 1 1/2 - 3"	HAMMER DRILLED HOLE	10.00	EA	0.0000	1.000	0.00	0.2600	1.000	2.60
240029	1 5/8" x 1 5/8"H	U-STRUT CHNL SGL-12G SLOT GALV	8.00	FT	1.3488	1.000	10.79	0.1225	1.000	0.98

Cost Code 800, MISCELLANEOUS/OTHER totals: \$38.54 8.70

Cost Code 901, DEMOLITION 0.00% of Job Total 1.73% of Job Total

Item #	Size	Description	Quantity	U/	Mat Unit	M-	Mat Result	Lab Unit	L-Fact	Lab Result
380105	10	EXISTING WIRE TO PULL OUT	630.00	FT				0.0060	1.000	3.78

Cost Code 901, DEMOLITION totals: \$0.00 3.78

Cost Code 920, SITE & CONSTRUCTION 0.00% of Job Total 1.87% of Job Total

Item #	Size	Description	Quantity	U/	Mat Unit	M-	Mat Result	Lab Unit	L-Fact	Lab Result
390187	12" x 36" DEEP	MACHINE TRENCHING	30.00	FT				0.0195	1.000	0.59
390223	12" WIDE	MACHINE COMPACT TRENCH	30.00	FT				0.0504	1.000	1.51
390246	12" x 36" DEEP	MACHINE BACKFILL TRENCH	30.00	FT				0.0660	1.000	1.98

Cost Code 920, SITE & CONSTRUCTION totals: \$0.00 4.08

Cost Code Q920, QUO SITE WORK 1.94% of Job Total 0.00% of Job Total

Item #	Size	Description	Quantity	U/	Mat Unit	M-	Mat Result	Lab Unit	L-Fact	Lab Result
390187	12" x 36" DEEP	MACHINE TRENCHING	30.00	FT	6.0000	1.000	180.00			
390223	12" WIDE	MACHINE COMPACT TRENCH	30.00	FT	0.0000	1.000	0.00			
390246	12" x 36" DEEP	MACHINE BACKFILL TRENCH	30.00	FT	0.0000	1.000	0.00			

Cost Code Q920, QUO SITE WORK totals: \$180.00 0.00



Updated Scope below after the detailed site visits between UTA and Skyline Electric.

PROPOSAL

Project: **UTA RTI Equipment Installation Scope Changes**

Date: 10/7/21

Skyline Electric Company appreciates the opportunity of providing you with a proposal for the above-mentioned project.

Item Name	Price
Salt Lake Central Intermodal	\$599.44
Farmington Station	\$(2,262.22)
Murray Central Station	\$699.21
Central Pointe Station	\$852.88
West Valley Station	\$630.06
Clearfield Station	\$29,454.76
Ogden Station	\$3,979.20
Total	\$33,953.33
<u>Additional Bond at 1.15%</u>	<u>\$390.46</u>
Total	\$34,343.79

Inclusions:

- See attached breakdown sheet for site details of scope change.

Exclusions:

- Pedestrian and Bus Management
- Additional work created by un-foreseen circumstances

Clarifications & Other:

- Assumed work schedule is day (1st) shift, Monday – Friday.
- Assumed full unaffected access to work area as needed.
- Our insurance limits and payment terms can be viewed at the link below. This proposal includes these conditions unless noted otherwise. [Insurance Limits & Payment Terms](#)

Skyline Electric Company offers this proposal to you in good faith for a period of Thirty Days. Your confidential handling of this proposal is greatly appreciated. The proposal price(s) contained in this proposal is conditioned upon present material and labor prices to provide you with the most competitive price available. In the event material or labor prices increase by more than 5% from the date of this proposal, Skyline Electric Company reserves the right to adjust its pricing and schedule to meet market fluctuations in material and labor costs.

The COVID-19 pandemic, its direct and indirect effects, and the resulting current and potential future restrictions imposed by governmental authorities are dynamic events that may affect the labor force, site restrictions, costs, means and methods to perform work, and the availability and delivery of goods and materials. The duration of the pandemic and related government restrictions is unknown at this time, these circumstances are not included within this proposal. While Skyline Electric Company will make every reasonable effort to meet schedules and delivery milestone dates, we cannot guarantee them and will notify you, amend and supplement this proposal and/or schedule as necessary when information is available.

Sincerely,

Cade Markle
Transportation Division Manager

Salt Lake Central**Credited Scope**

Wire (3 - 12 AWG stranded 90° C copper wire, incl install through new or existing conduit)	LF	48	\$2.50	\$120.00
Concrete Patch (12" wide)	LF	6	\$47.00	\$282.00
Post Fabrication Items**				
Steel Tubing 6"x6"x1/2"x20'	EA	1	\$810.00	\$810.00
Base plates, hand hole covers, nuts bolts, misc parts	EA	1	\$320.00	\$320.00
Cut Weld Labor	LUMP	1	\$1,200.00	\$1,200.00
Powder Coating	LUMP	1	\$350.00	\$350.00
Mounting Brackets	EA	1	\$111.00	\$111.00
Install Post (half day 2 person crew)	LUMP	1	\$310.00	\$310.00
Post Foundation Items**				
Drill 6' deep 2' dia. shaft	EA	1	\$1,050.00	\$1,050.00
Conduit	EA	1	\$130.00	\$130.00
Structural Concrete	EA	1	\$210.00	\$210.00
Misc parts - sono Tube, 2x4, bolt pattern	EA	1	\$1,270.00	\$1,270.00
Form Labor	LUMP	1	\$280.00	\$280.00
Sub Total				\$6,443.00
Contractor Markup, Overhead, & Profit			12%	\$764.64
Contractor Management Fee			5%	\$350.45
Credit Total				\$7,558.08

Changed Scope

Steel Tubing 6"x6"x1/2"x20'	EA	1	\$480.00	\$480.00
Base plates, hand hole covers, nuts bolts, misc parts	EA	1	\$195.00	\$195.00
Cut Weld Labor	LUMP	1	\$650.00	\$650.00
Powder Coating	LUMP	1	\$80.00	\$80.00
Mounting Brackets	EA	1	\$46.00	\$46.00
Install Post	LUMP	1	\$2,385.00	\$2,385.00
Wire (3 - 12 AWG stranded 90° C copper wire, incl install through new or existing conduit)	LF	100	\$2.50	\$250.00
Miscellaneous Conduit work	LUMP	1	\$2,868.00	\$2,868.00
Sub Total				\$6,954.00
Contractor Markup, Overhead, & Profit			12%	\$825.28
Contractor Management Fee			5%	\$378.24
Changed Scope Total				\$8,157.52

Farmington Station

Credited Scope

Horizontal Conduit - Above Ground (2 @ 2", incl mounting equip)	LF	66	\$35.35	\$2,333.00
Vertical Conduit - Estimated (2 @ 2", incl mounting equip)	LF	30	\$47.06	\$1,412.00
Wire (3 - 12 AWG stranded 90° C copper wire, incl install through new or existing conduit)	LF	48	\$2.50	\$120.00
Concrete Patch (12" wide)	LF	6	\$47.00	\$282.00
Post Fabrication Items**				
Steel Tubing 6"x6"x1/2"x20'	EA	1	\$810.00	\$810.00
Base plates, hand hole covers, nuts bolts, misc parts	EA	1	\$320.00	\$320.00
Cut Weld Labor	LUMP	1	\$1,200.00	\$1,200.00
Powder Coating	LUMP	1	\$350.00	\$350.00
Mounting Brackets	EA	1	\$111.00	\$111.00
Install Post (half day 2 person crew)	LUMP	1	\$310.00	\$310.00
Post Foundation Items**				
Drill 6' deep 2' dia. shaft	EA	1	\$1,050.00	\$1,050.00
Conduit	EA	1	\$130.00	\$130.00
Structural Concrete	EA	1	\$210.00	\$210.00
Misc parts - sono Tube, 2x4, bolt pattern	EA	1	\$1,270.00	\$1,270.00
Form Labor	LUMP	1	\$280.00	\$280.00
Sub Total				\$10,188

Contractor Markup, Overhead, & Profit			12%	\$1,209.08
Contractor Management Fee			5%	\$554.14
Credit Total				\$11,951.22

Changed Scope

Steel Tubing 6"x6"x1/2"x20'	EA	1	\$498.00	\$498.00
Base plates, hand hole covers, nuts bolts, misc parts	EA	1	\$210.00	\$210.00
Cut Weld Labor	LUMP	1	\$675.00	\$675.00
Powder Coating	LUMP	1	\$80.00	\$80.00
Mounting Brackets	EA	1	\$46.00	\$46.00
Install Post	LUMP	1	\$2,385.00	\$2,385.00
Wire (3 - 12 AWG stranded 90° C copper wire, incl install through new or existing conduit)	LF	100	\$2.50	\$250.00
Miscellaneous Conduit work	LUMP	1	\$5,545.00	\$5,545.00
Sub Total				\$9,689.00

Contractor Markup, Overhead, & Profit			12%	\$1,149.86
Contractor Management Fee			5%	\$527.00
Changed Scope Total				\$11,365.86

Salt Lake Central**Credited Scope**

Wire (3 - 12 AWG stranded 90° C copper wire, incl install through new or existing conduit)	LF	48	\$2.50	\$120.00
Concrete Patch (12" wide)	LF	6	\$47.00	\$282.00
Post Fabrication Items**				
Steel Tubing 6"x6"x1/2"x20'	EA	1	\$810.00	\$810.00
Base plates, hand hole covers, nuts bolts, misc parts	EA	1	\$320.00	\$320.00
Cut Weld Labor	LUMP	1	\$1,200.00	\$1,200.00
Powder Coating	LUMP	1	\$350.00	\$350.00
Mounting Brackets	EA	1	\$111.00	\$111.00
Install Post (half day 2 person crew)	LUMP	1	\$310.00	\$310.00
Post Foundation Items**				
Drill 6' deep 2' dia. shaft	EA	1	\$1,050.00	\$1,050.00
Conduit	EA	1	\$130.00	\$130.00
Structural Concrete	EA	1	\$210.00	\$210.00
Misc parts - sono Tube, 2x4, bolt pattern	EA	1	\$1,270.00	\$1,270.00
Form Labor	LUMP	1	\$280.00	\$280.00
Sub Total				\$6,443.00

Contractor Markup, Overhead, & Profit			12%	\$764.64
Contractor Management Fee			5%	\$350.45
Credit Total				\$7,558.08

Changed Scope

Steel Tubing 6"x6"x1/2"x20'	EA	1	\$480.00	\$480.00
Base plates, hand hole covers, nuts bolts, misc parts	EA	1	\$195.00	\$195.00
Cut Weld Labor	LUMP	1	\$650.00	\$650.00
Powder Coating	LUMP	1	\$80.00	\$80.00
Mounting Brackets	EA	1	\$46.00	\$46.00
Install Post	LUMP	1	\$2,385.00	\$2,385.00
Wire (3 - 12 AWG stranded 90° C copper wire, incl install through new or existing conduit)	LF	100	\$2.50	\$250.00
Miscellaneous Conduit work	LUMP	1	\$2,868.00	\$2,868.00
Sub Total				\$6,954.00

Contractor Markup, Overhead, & Profit			12%	\$825.28
Contractor Management Fee			5%	\$378.24
Changed Scope Total				\$8,157.52

Central Pointe Station

Credited Scope

Wire (3 - 12 AWG stranded 90° C copper wire, incl install through new or existing conduit)	LF	555	\$ 2.50	\$ 1,387.50
Sub Total				\$ 1,387.50

Contractor Markup, Overhead, & Profit			12%	\$ 164.66
Contractor Management Fee			5%	\$ 75.47
Credited Scope Total				\$ 1,627.63

Changed Scope

Wire adjustment to #10	LF	555	\$ 3.81	\$ 2,114.55
Sub Total				\$ 2,114.55

Contractor Markup, Overhead, & Profit			12%	\$ 250.95
Contractor Management Fee			5%	\$ 115.01
Changed Scope Total				\$ 2,480.51

West Valley Station**Credited Scope**

Wire (3 - 12 AWG stranded 90° C copper wire, incl install through new or existing conduit)	LF	410	\$2.50	\$1,025.00
Sub Total				\$1,025.00

Contractor Markup, Overhead, & Profit			12%	\$121.64
Contractor Management Fee			5%	\$55.75
Credited Scope Total				\$1,202.40

Changed Scope

Wire adjustment to #10	LF	410	\$ 3.81	\$1,562.10
Sub Total				\$1,562.10

Contractor Markup, Overhead, & Profit			12%	\$185.39
Contractor Management Fee			5%	\$84.97
Changed Scope Total				\$1,832.45

Clearfield Station**Credited Scope**

Wire (3 - 12 AWG stranded 90° C copper wire, incl install through new or existing conduit)	LF	865	\$2.50	\$2,162.50
Sub Total				\$2,162.50

Contractor Markup, Overhead, & Profit			12%	\$256.64
Contractor Management Fee			5%	\$117.62
Credited Scope Total				\$2,536.76

Changed Scope

Junction Box	EA	1	\$1,200.00	\$1,200.00
Horizontal Conduit - Buried (2 @ 2" dia sch 40 PVC, incl excavation, concrete, bedding, backfill, & compaction - 2' deep)	LF	610	\$34.53	\$21,063.30
Wire adjustment to #8	LF	865	\$5.79	\$5,008.35
Sub Total				\$27,271.65

Contractor Markup, Overhead, & Profit			12%	\$3,236.52
Contractor Management Fee			5%	\$1,483.35
Changed Scope Total				\$31,991.52

Ogden Station**Credited Scope**

Wire (3 - 12 AWG stranded 90° C copper wire, incl install through new or existing conduit)	LF	557	\$2.50	\$1,392.50
Sub Total				\$1,392.50

Contractor Markup, Overhead, & Profit			12%	\$165.26
Contractor Management Fee			5%	\$75.74
Credited Scope Total				\$1,633.50

Changed Scope

Wire adjustment to #10	LF	557	\$ 8.59	\$4,784.63
Sub Total				\$4,784.63

Contractor Markup, Overhead, & Profit			12%	\$567.83
Contractor Management Fee			5%	\$260.24
Changed Scope Total				\$5,612.70

Richards

SHEET METAL WORKS, INC.

2680 Industrial Drive Ogden UT 84401
 Ogden (801) 621-3341 SLC (801) 364-3979
 Fax (801) 392-9567

Precision Metal Fabrication since 1928

Celebrating 93 Years of Service

Quote To:	Date: 10/4/2021
SKYLINE ELECTRIC COMPANY PO BOX 26666 SALT LAKE CITY UT 84126-0666	Reference:
	Sales Person: Tom Davidson

Phone: 801-972-3656

Fax: 801-973-9287

Quote Number: 86107**QUOTE**

10/4/2021

Page: 1

Line	Part Number	Description	Revision	Drawing
1	UTA SIGN POST	FABRICATE AND DELIVER SIGN POST PER PROVIDED DRAWINGS		

*POWDER COAT WITH STANDARD
POWDER (COLOR TBD)*

*SIGN FOUNDATION NOT
INCLUDED*

ANCHOR BOLTS NOT INCLUDED

*NEOPRENE SEALS NOT
INCLUDED*

*HAND HOLE BOLT PLATE
FIGURED AT 1" THICK (SECTION
A-A)*

Quantity **UM** **Unit Price** **Extended Price**

Line	Part Number	Description	Revision	Drawing
2	UTA FARM MOUNT ARM	FABRICATE AND DELIVER SIGN MOUNTING ARM PER PROVIDED DRAWINGS FARMINGTON		

*POWDER COAT WITH STANDARD
POWDER (COLOR TBD)*

*SIGN FOUNDATION NOT
INCLUDED*

ANCHOR BOLTS NOT INCLUDED

Quote Number: 86107

QUOTE

10/4/2021

Page:

2

<u>Quantity</u>	<u>UM</u>	<u>Unit Price</u>	<u>Extended Price</u>
1.00	EA	\$1,509.00	\$1,509.00

<u>Line</u>	<u>Part Number</u>	<u>Description</u>	<u>Revision</u>	<u>Drawing</u>
3	UTA SLC MOUNT ARM	FABRICATE AND DELIVER SIGN MOUNTING ARM PER PROVIDED DRAWINGS SALT LAKE CITY		

POWDER COAT WITH STANDARD POWDER (COLOR TBD)

SIGN FOUNDATION NOT INCLUDED

ANCHOR BOLTS NOT INCLUDED

<u>Quantity</u>	<u>UM</u>	<u>Unit Price</u>	<u>Extended Price</u>
1.00	EA	\$1,451.00	\$1,451.00

Terms and Conditions

PROGRAMMING: All parts produced generally require cutting geometry. Quotes are based on the need for accurate CAD geometry to use in our cutting and forming equipment. Receiving a usable CAD file at the time of the Request for Quote (RFQ) will enable Richards Sheet Metal to calculate cutting and forming to the most accurate levels possible. Costs to program parts will be included in the quote provided if the customer has not provided CAD files with the RFQ solicitation. All files should be drawn using a 1 to 1 scale. Richards Sheet Metal utilizes Solidworks as our primary CAD platform but we are able to work with other commercially available CAD programs. Acceptable file types are: .sldprt, .prt, .iges, .step, .stp (STEP AP214), .ifc (IFC 2X3), DXF, Parasolid (*.x_t), dwg.

QUALITY: Quality documents may be provided upon request include Certificates of Compliance/Conformance (CofC), and Material Test Reports. The request for these documents should be made with the RFQ, but no later than with the Purchase Order. Further quality documentation can be provided at an additional cost (Visual/Dimensional inspection reports, PPAP, ISIR, FAIR). Contact your sales representative if any of these are required. Material surface quality will be according to industry standards for commercial materials unless other finishes are specified by the customer prior to the commencement of the jobs.

GENERAL TOLERANCES: Laser Cutting Flat*:

	± .010" on materials 1/2" and thinner
	± .015" on material 5/8" and thicker
	One (1) microtab / microjoint allowed per part at up to 15% of the material thickness
Laser Cutting Tube:	± .010" on features
	± .030" on locations and lengths
Forming:	Maximum Length formed 162" (dependent on material thickness)
	.0157" to .375" thick material ± 1 Degree on bends
	± .030" on lengths
	Greater than .375": ± 1 Degree on bends
	± .060" on lengths
Welded parts:	± .030" on dimensions
	± 2 Degrees on angles
Machining:	± .005" on features

*Tolerances closer than those shown may be available based on material and the part configuration.

INSPECTION: All claims regarding product conformity must be made within 20 days of receipt and notification provided within this time for any rejection(s). Richards will take immediate and necessary actions to credit, rework or replace nonconforming parts/product. If RSM is not notified within 30 days of delivery, customer releases RSM of liability for repair or replacement.

WARRANTY: RSM warrants its goods to be free from defects in material and/or workmanship under normal and intended use and service for a period of one (1) year from the date of purchase. Seller does not warrant its goods against any defect except as set forth above, and Seller is not responsible for, and it does not warrant against, any defect or damage caused by transportation, storage, improper installation, maintenance, internal or external hostile environment, misuse, abuse, negligence, accident, modification, tampering, the attachment of any unauthorized accessory, alteration to the goods, or any other conditions whatsoever that do not constitute a defect in material and/or workmanship. Sellers sole responsibility under this Express warranty shall be, at its option, to either repair or replace any goods which fail during the warranty period, provided that Buyer has promptly reported same to Seller in writing, and complies with the provisions of this Warranty.

PRICING AND MATERIAL: **PRICING WILL BE BASED ON THE MATERIAL MARKET PRICE ON THE DAY OF ORDER RECEIPT.** Supplier imposed material surcharges may be applicable on materials at the time of the order. Quotes include material unless noted as "Customer Supplied Material"

CUSTOMER SUPPLIED MATERIAL: **Flat sheet and plate:** Customer supplied sheet must not be longer than 162" or wider than 80" for materials up to 1". All material must be palletized and banded. No loose materials will be offloaded. Coordinate with RSM sales personnel for all material over 60" wide or 120" long.

Tube and shape: Customer supplied tube and structural shapes must be a minimum of 10' in length and no longer than 45'. All tube and shapes must have square cut ends. Materials received over the lengths specified with irregular ends will be subject to an additional processing charge. Any coatings on tube, pipe, or structural shapes may result in additional processing charges to sandblast materials prior to cutting. Materials are preferred to be bare of any finishes or excessive markings.

Programming and nesting on customer material: Programming and calculating part yields will not begin until the received part sizes and lengths are verified. If materials are not consistent in size and additional fee may be added to accommodate the additional time needed to nest for best yield on the various sizes and lengths provided.

Remnant material: At the time of the request for quote the customer needs to communicate if any remnant material is to be returned to the customer. Excess material not picked up will be disposed of in the most economical manner possible within 10 days of shipment.

Customer material receiving: Deliveries of customer supplied materials must be scheduled with the RSM Shipping Manager (801-621-3341 Ext 3044). Material is only received from 7AM to 3PM M-Th and 7AM to 2PM Friday. Any deliveries outside of these times will need to be coordinated with the Shipping Manager.

LEAD TIMES: All estimated lead times are subject to change and are based on current committed shop capacity **ON THE DATE THE ORDER IS RECEIVED.** Please contact your sales representative for current lead time.

PAYMENT TERMS: All orders for customers without accounts must be paid in full at the time the order is placed. For customers of record, the terms are Net 30 unless otherwise agreed upon by both parties prior to the placement of the order. Any modification to these terms must be presented in advance to the RSM financial department for consideration.

SALES TAX: Sales tax is not included in the quoted price and will be added when the invoice is generated. If qualified as tax exempt, please provide a copy of the exemption certificate and notify your sales representative at the time of the order. Rev.01 082619

R & S Directional Underground Drilling
6144 Vista Mesa Dr
West Valley City, UT 84128 US
randsdrilling@gmail.com



ADDRESS

Skyline Electric Company
1848 West 2300 South
WEST VALLEY CITY, UT 84119
United States

SHIP TO

Skyline Electric Company
1848 West 2300 South
WEST VALLEY CITY, UT 84119
United States

Estimate 1087

DATE 10/04/2021

DATE	ACTIVITY	DESCRIPTION	QTY	RATE	AMOUNT
	Sales	Span Placement Directional Bore Install 2x2"	610	21.00	12,810.00
	Sales	Conduit Price (2" INNER DUCT- GRAY, SDR 11)	610	2.34	1,427.40
	Sales	Potholes W/Restoration	5	250.00	1,250.00
	Sales	CONCRETE TEAR OUT/REPLACE (PER SQFT) ESTIMATION	40	45.00	1,800.00
	Sales	CLEARFIELD PERMITTING (COST +20%)	1	1.00	1.00

Job Number: E-015
Job Address: 1250 South State Street, Clearfield, Utah
(Clearfield Station)

TOTAL \$17,288.40

Accepted By

Accepted Date

EXHIBIT C

FEDERAL CLAUSES FOR CONSTRUCTION CONTRACTS

ACCESS REQUIREMENTS FOR PERSONS WITH DISABILITIES

Contractor shall comply with 49 USC 5301(d), stating federal policy that the elderly and persons with disabilities have the same rights as other persons to use mass transportation services and facilities and that special efforts shall be made in planning and designing those services and facilities to implement that policy. Contractor shall also comply with all applicable requirements of Section 504 of the Rehabilitation Act of 1973, as amended, 29 USC 794, which prohibits discrimination on the basis of disability; the Americans with Disabilities Act of 1990 (ADA), as amended, 42 USC 12101 et seq., which requires that accessible facilities and services be made available to persons with disabilities; and the Architectural Barriers Act of 1968, as amended, 42 USC §4151 et seq., which requires that buildings and public accommodations be accessible to individuals with disabilities.

ACCESS TO RECORDS AND REPORTS

Contractor will retain, and will require its subcontractors of all tiers to retain, complete and readily accessible records related in whole or in part to the Contract, including, but not limited to, data, documents, reports, statistics, sub-agreements, leases, subcontracts, arrangements, other third party agreements of any type, and supporting materials related to those records.

Contractor agrees to comply with the record retention requirements in accordance with 2 CFR §200.333. Contractor shall maintain all books, records, accounts and reports required under the Contract for a period equal to the longer of: (i) three (3) years; or (ii) such longer period as may be specified in the Contract (except in the event of litigation or settlement of claims arising from the performance of the Contract, in which case records shall be maintained until the full and final disposition of all such claims or litigation (including appeals related thereto)).

Contractor agrees to provide sufficient access to United States Department of Transportation, Federal Transit Administration (FTA) and its contractors to inspect and audit records and information related to performance of the Contract as reasonably may be required.

Contractor agrees to permit FTA and its contractors access to the sites of performance under the Contract as reasonably may be required.

BONDING REQUIREMENTS [Applicable Only to Contracts valued at more than \$150,000]

Unless a different requirement is set forth in the Contract, Contractor shall maintain the following bonds:
A bid guarantee from each bidder equivalent to five percent of the bid price. The "bid guarantee" must consist of a firm commitment such as a bid bond, certified check, or other negotiable instrument accompanying a bid as assurance that the bidder will, upon acceptance of the bid, execute such contractual documents as may be required within the time specified.

A performance bond in the amount of **100%** of the Contract value is required by the Recipient to ensure faithful performance of the Contract. The performance bond shall be provided by Contractor and shall remain in full force for the term of the Contract. Contractor will provide the performance bond to UTA within ten (10) business days from execution of the Contract. The performance bond must be provided by a fully qualified surety company acceptable to the UTA and listed as a company currently authorized under 31 CFR Part 22 as possessing a certificate of authority as described thereunder. UTA may require additional performance bond protection if the Contract price is increased. The increase in protection shall generally equal 100 percent of the increase in Contract price. UTA may secure additional protection by directing Contractor to increase the amount of the existing bond or to obtain an additional bond.

A labor and materials payment bond equal to the full value of the Contract must be furnished by Contractor to UTA as security for payment by Contractor and subcontractors for labor, materials, and rental of equipment. The bond may be issued by a fully qualified surety company acceptable to UTA and listed as a company currently authorized under 31 CFR Part 223 as possessing a certificate of authority as described thereunder.

BUY AMERICA CERTIFICATION [Applicable Only to Contracts valued at more than \$150,000]

Contractor shall comply with 49 USC 5323(j) and 49 CFR 661, as amended by MAP-21 stating that federal funds may not be obligated unless steel, iron and manufactured products used in FTA-funded projects are produced in the United States, unless a waiver has been granted by FTA or the product is subject to a general waiver. General waivers are listed in 49 CFR 661.7. Separate requirements for rolling stock are set out at 49 USC §5323(j)(2)(C) and 49 CFR §661.11. Rolling stock must be assembled in the United States and have the applicable percentage of domestic content required by 49 USC 5323(j) and 49 CFR 661. Contractor shall be responsible for ensuring that lower tier contractors and subcontractors are in compliance with these requirements. All respondents to the UTA solicitation for the Contract must include the appropriate Buy America certification with their responses and any response that is not accompanied by a completed Buy America Certification will be rejected as nonresponsive.

CARGO PREFERENCE [Applicable Only to Contracts Involving Equipment, Materials or Commodities Transported by Ocean Vessels]

Contractor shall: (i) use privately owned US-Flag commercial vessels to ship at least 50% of the gross tonnage (computed separately for dry bulk carriers, dry cargo liners and tankers) involved, whenever shipping any equipment, materials or commodities pursuant to the Contract, to the extent such vessels are available at fair and reasonable rates for US flag commercial vessels; (ii) furnish, within 20 working days following the loading date of shipments originating within the US or within 30 working days following the loading date of shipments originating outside the US, a legible copy of a rated, "on-board" commercial bill-of-lading in English for each shipment of cargo described herein to the Division of National Cargo, Office of Market Development, Maritime Administration, Washington, DC 20590 and to UTA (through Contractor in the case of a subcontractor's bill-of-lading.); and (iii) include these requirements in all subcontracts issued pursuant to the Contract when the subcontract involves the transport of equipment, material or commodities by ocean vessel.

CHANGES TO FEDERAL REQUIREMENTS

Contractor shall comply with all applicable regulations, policies, procedures and directives of the FTA. Applicable regulations, policies, procedures and directives include, without limitation, those listed directly or by reference in the Master Agreement between UTA and FTA, as they may be amended or promulgated from time to time during the term of the Contract. Contractor's failure to comply shall constitute a material breach of the Contract.

CIVIL RIGHTS REQUIREMENTS

In accordance with Federal transit law at 49 USC §5332, Contractor agrees that it will not discriminate against any employee or applicant for employment because of race, color, religion, national origin, sex, disability, or age. In addition, Contractor agrees to comply with applicable Federal implementing regulations and other implementing requirements FTA may issue including, without limitation the following equal employment opportunity requirements:

(1) **Race, Color, Creed, National Origin, Sex** – In accordance with Title VII of the Civil Rights Act, as amended, 42 USC §2000e et seq., and federal transit laws at 49 USC §5332, Contractor agrees to comply with all applicable equal employment opportunity requirements of U.S. Department of Labor (U.S. DOL) regulations, "Office of Federal Contract Compliance Programs, Equal Employment Opportunity, Department of Labor," 41 CFR Part 60, and Executive Order No. 11246, "Equal Employment Opportunity in Federal Employment," September 24, 1965, 42 USC §2000e note, as amended by any later Executive Order that amends or supersedes it, referenced in 42 USC §2000e note. Contractor agrees to take affirmative action to ensure that applicants are employed, and that employees are treated during employment, without regard to their race, color, religion, national origin, or sex (including sexual orientation and gender identity). Such action shall include, but not be limited to, the following: employment, promotion, demotion or transfer, recruitment or recruitment advertising, layoff or termination; rates of pay or other forms of compensation; and selection for training, including apprenticeship. In addition, Contractor agrees to comply with any implementing requirements FTA may issue.

(2) **Age** – In accordance with the Age Discrimination in Employment Act, 29 USC §§621-634, U.S. Equal Employment Opportunity Commission (U.S. EEOC) regulations, "Age Discrimination in Employment Act," 29 CFR

Part 1625, the Age Discrimination Act of 1975, as amended, 42 USC §6101 et seq., U.S. Health and Human Services regulations, "Nondiscrimination on the Basis of Age in Programs or Activities Receiving Federal Financial Assistance," 45 CFR Part 90, and federal transit law at 49 USC §5332, Contractor agrees to refrain from discrimination against present and prospective employees for reason of age. In addition, Contractor agrees to comply with any implementing requirements FTA may issue.

(3) **Disabilities** – In accordance with Section 504 of the Rehabilitation Act of 1973, as amended, 29 USC §794, the Americans with Disabilities Act of 1990, as amended, 42 USC §12101 et seq., the Architectural Barriers Act of 1968, as amended, 42 USC §4151 et seq., and federal transit law at 49 USC §5332, Contractor agrees that it will not discriminate against individuals on the basis of disability. In addition, Contractor agrees to comply with any implementing requirements FTA may issue.

Contractor also agrees to include these requirements in each subcontract financed in whole or in part with federal assistance provided by FTA, modified only if necessary to identify the affected parties.

CLEAN AIR [Applicable Only to Contracts valued at more than \$150,000]

Contractor shall comply with all applicable standards, orders or regulations pursuant to the Clean Air Act, 42 USC 7401 et seq. Contractor agrees that it will not use any violating facilities. Contractor shall report each violation to UTA and understands and agrees that UTA will, in turn, report each violation as required to FTA and the appropriate EPA Regional Office. Contractor shall include these requirements in each subcontract exceeding \$150,000 financed in whole or in part with FTA assistance.

CLEAN WATER [Applicable Only to Contracts valued at more than \$150,000]

Contractor shall comply with all applicable standards, orders or regulations issued pursuant to the Federal Water Pollution Control Act, as amended, 33 USC 1251 et seq. Contractor shall report each violation to UTA and understands and agrees that UTA will, in turn, report each violation as required to FTA and the appropriate EPA Regional Office. Contractor shall include these requirements in each subcontract exceeding \$150,000 financed in whole or in part with FTA assistance.

CONFORMANCE WITH NATIONAL ITS ARCHITECTURE [Applicable Only to Contracts and Solicitations for Intelligent Transportation Systems]

To the extent applicable, Contractor agrees to conform to the National Intelligent Transportation Systems (ITS) Architecture and Standards as required by SAFETEA-LU § 5307(c), 23 U.S.C. § 512 note, and comply with FTA Notice, "FTA National ITS Architecture Policy on Transit Projects" 66 Fed. Reg. 1455 et seq., January 8, 2001, and any subsequent further implementing directives, except to the extent FTA determines otherwise in writing.

CONTRACT WORK HOURS AND SAFETY STANDARDS ACT [Applicable Only to Contracts valued at more than \$150,000]

(1) **Overtime Requirements** – Neither Contractor nor any subcontractor contracting for any part of the work under the Contract which may require or involve the employment of laborers or mechanics shall require or permit any such laborer or mechanic in any workweek in which he or she is employed on such work to work in excess of forty hours in such workweek unless such laborer or mechanic receives compensation at a rate not less than one and one-half times the basic rate of pay for all hours worked in excess of forty hours in such workweek.

(2) **Violation; Liability for Unpaid Wages; Liquidated Damages** – In the event of any violation of the clause set forth in paragraph (1) of this section, Contractor and any subcontractor responsible therefore shall be liable for the unpaid wages. In addition, Contractor and such subcontractor shall be liable to the United States for liquidated damages. Such liquidated damages shall be computed with respect to each individual laborer or mechanic, including watchmen and guards, employed in violation of the clause set forth in paragraph (1) of this section, in the sum of \$10 for each calendar day on which such individual was required or permitted to work in excess of the standard workweek of forty hours without payment of the overtime wages required by the clause set forth in paragraph (1) of this section.

(3) **Withholding for Unpaid Wages and Liquidated Damages** – UTA shall upon its own action or upon written request of an authorized representative of the Department of Labor withhold or cause to be withheld, from any moneys

payable on account of work performed by Contractor or any subcontractor under the Contract or any other federal contract with Contractor, or any other federally-assisted contract subject to the Contract Work Hours and Safety Standards Act, which is held by Contractor, such sums as may be determined to be necessary to satisfy any liabilities of Contractor or any subcontractor for unpaid wages and liquidated damages as provided in the clause set forth in paragraph (2) of this section.

(4) **Subcontracts** – Contractor and all subcontractors shall insert in any subcontracts the clauses set forth in paragraphs (1) through (4) of this section and also a clause requiring the subcontractors to include these clauses in any lower tier subcontracts. Contractor shall be responsible for compliance by any subcontractor or lower tier subcontractor with the clauses set forth in paragraphs (1) through (4) of this section.

DAVIS-BACON ACT PREVAILING WAGE AND COPELAND ACT ANTI-KICKBACK REQUIREMENTS

(1) **Minimum wages** – (i) All laborers and mechanics employed or working upon the site of the work (or under the United States Housing Act of 1937 or under the Housing Act of 1949 in the construction or development of the project), will be paid unconditionally and not less often than once a week, and without subsequent deduction or rebate on any account (except such payroll deductions as are permitted by regulations issued by the Secretary of Labor under the Copeland Act (29 CFR Part 3)), the full amount of wages and bona fide fringe benefits (or cash equivalents thereof) due at time of payment computed at rates not less than those contained in the wage determination of the Secretary of Labor which is attached hereto and made a part hereof, regardless of any contractual relationship which may be alleged to exist between Contractor and such laborers and mechanics.

Contributions made or costs reasonably anticipated for bona fide fringe benefits under Section 1(b)(2) of the Davis-Bacon Act on behalf of laborers or mechanics are considered wages paid to such laborers or mechanics, subject to the provisions of paragraph (1)(iv) of this section; also, regular contributions made or costs incurred for more than a weekly period (but not less often than quarterly) under plans, funds, or programs which cover the particular weekly period, are deemed to be constructively made or incurred during such weekly period. Such laborers and mechanics shall be paid the appropriate wage rate and fringe benefits on the wage determination for the classification of work actually performed, without regard to skill, except as provided in 29 CFR Part 5.5(a)(4). Laborers or mechanics performing work in more than one classification may be compensated at the rate specified for each classification for the time actually worked therein: Provided that the employer's payroll records accurately set forth the time spent in each classification in which work is performed. The wage determination (including any additional classifications and wage rates conformed under paragraph (1)(ii) of this section) and the Davis-Bacon poster (WH-1321) shall be posted at all times by Contractor and its subcontractors at the site of the work in a prominent and accessible place where it can be easily seen by the workers.

(ii)(A) UTA's Civil Rights Compliance Office shall require that any class of laborers or mechanics, including helpers, which is not listed in the wage determination and which is to be employed under the Contract shall be classified in conformance with the wage determination. UTA's Civil Rights Compliance Office shall approve an additional classification and wage rate and fringe benefits therefore only when the following criteria have been met:

Except with respect to helpers as defined as 29 CFR 5.2(n)(4), the work to be performed by the classification requested is not performed by a classification in the wage determination; and

(1) The classification is utilized in the area by the construction industry; and

(2) The proposed wage rate, including any bona fide fringe benefits, bears a reasonable relationship to the wage rates contained in the wage determination; and

(3) With respect to helpers as defined in 29 CFR 5.2(n)(4), such a classification prevails in the area in which the work is performed.

(B) If Contractor and the laborers and mechanics to be employed in the classification (if known), or their representatives, and UTA's Civil Rights Compliance Office agree on the classification and wage rate (including the amount designated for fringe benefits where appropriate), a report of the action taken shall be sent by UTA's Civil Rights Compliance Office to the Administrator of the Wage and Hour Division, Employment Standards Administration, U.S. Department of Labor, Washington, DC 20210. The Administrator, or an authorized representative, will approve, modify, or disapprove every additional classification action within 30 days of receipt and so advise UTA's Civil Rights Compliance Office or will notify UTA's Civil Rights Compliance Office within the 30-day period that additional time is necessary.

(C) In the event Contractor, the laborers or mechanics to be employed in the classification or their representatives, and UTA's Civil Rights Compliance Office do not agree on the proposed classification and wage rate (including the amount designated for fringe benefits, where appropriate), UTA's Civil Rights Compliance Office shall refer the questions, including the views of all interested parties and the recommendation of UTA's Civil Rights Compliance Office, to the Administrator for determination. The Administrator, or an authorized representative, will issue a determination within 30 days of receipt and so advise UTA's Civil Rights Compliance Office or will notify UTA's Civil Rights Compliance Office within the 30-day period that additional time is necessary.

(D) The wage rate (including fringe benefits where appropriate) determined pursuant to paragraph (1)(ii) (B) or (C) of this section, shall be paid to all workers performing work in the classification under the Contract from the first day on which work is performed in the classification.

(iii) Whenever the minimum wage rate prescribed in the Contract for a class of laborers or mechanics includes a fringe benefit which is not expressed as an hourly rate, Contractor shall either pay the benefit as stated in the wage determination or shall pay another bona fide fringe benefit or an hourly cash equivalent thereof.

(iv) If Contractor does not make payments to a trustee or other third person, Contractor may consider as part of the wages of any laborer or mechanic the amount of any costs reasonably anticipated in providing bona fide fringe benefits under a plan or program, Provided, That the Secretary of Labor has found, upon the written request of Contractor, that the applicable standards of the Davis-Bacon Act have been met. The Secretary of Labor may require Contractor to set aside in a separate account assets for the meeting of obligations under the plan or program.

(v)(A) UTA's Civil Rights Compliance Office shall require that any class of laborers or mechanics which is not listed in the wage determination and which is to be employed under the Contract shall be classified in conformance with the wage determination. UTA's Civil Rights Compliance Office shall approve an additional classification and wage rate and fringe benefits therefore only when the following criteria have been met:

(1) The work to be performed by the classification requested is not performed by a classification in the wage determination; and

(2) The classification is utilized in the area by the construction industry; and

(3) The proposed wage rate, including any bona fide fringe benefits, bears a reasonable relationship to the wage rates contained in the wage determination.

(B) If Contractor and the laborers and mechanics to be employed in the classification (if known), or their representatives, and UTA's Civil Rights Compliance Office agree on the classification and wage rate (including the amount designated for fringe benefits where appropriate), a report of the action taken shall be sent by UTA's Civil Rights Compliance Office to the Administrator of the Wage and Hour Division, Employment Standards Administration, Washington, DC 20210. The Administrator, or an authorized representative, will approve, modify, or disapprove every additional classification action within 30 days of receipt and so advise UTA's Civil Rights Compliance Office or will notify UTA's Civil Rights Compliance Office within the 30-day period that additional time is necessary.

(C) In the event Contractor, the laborers or mechanics to be employed in the classification or their representatives, and UTA's Civil Rights Compliance Office do not agree on the proposed classification and wage rate (including the amount designated for fringe benefits, where appropriate), UTA's Civil Rights Compliance Office shall refer the questions, including the views of all interested parties and the recommendation of UTA's Civil Rights Compliance Office, to the Administrator for determination. The Administrator, or an authorized representative, will issue a determination within 30 days of receipt and so advise UTA's Civil Rights Compliance Office or will notify UTA's Civil Rights Compliance Office within the 30-day period that additional time is necessary.

(D) The wage rate (including fringe benefits where appropriate) determined pursuant to paragraphs (1)(v) (B) or (C) of this section, shall be paid to all workers performing work in the classification under the Contract from the first day on which work is performed in the classification.

(2) **Withholding** – UTA shall upon its own action or upon written request of an authorized representative of the Department of Labor withhold or cause to be withheld from Contractor under the Contract or any other federal contract for which Contractor is the prime contractor, or any other federally-assisted contract subject to Davis-Bacon prevailing wage requirements, which is held by Contractor, so much of the accrued payments or advances as may be considered

necessary to pay laborers and mechanics, including apprentices, trainees, and helpers, employed by Contractor or any subcontractor the full amount of wages required by the Contract. In the event of failure to pay any laborer or mechanic, including any apprentice, trainee, or helper, employed or working on the site of the work (or under the United States Housing Act of 1937 or under the Housing Act of 1949 in the construction or development of the project), all or part of the wages required by the Contract, UTA may, after written notice to Contractor, sponsor, applicant, or owner, take such action as may be necessary to cause the suspension of any further payment, advance, or guarantee of funds until such violations have ceased.

(3) **Payrolls and basic records** – (i) Payrolls and basic records relating thereto shall be maintained by Contractor during the course of the work and preserved for a period of three years thereafter for all laborers and mechanics working at the site of the work (or under the United States Housing Act of 1937, or under the Housing Act of 1949, in the construction or development of the project). Such records shall contain the name, address, and social security number of each such worker, his or her correct classification, hourly rates of wages paid (including rates of contributions or costs anticipated for bona fide fringe benefits or cash equivalents thereof of the types described in Section 1 (b)(2)(B) of the Davis-Bacon Act), daily and weekly number of hours worked, deductions made and actual wages paid. Whenever the Secretary of Labor has found under 29 CFR 5.5(a)(1)(iv) that the wages of any laborer or mechanic include the amount of any costs reasonably anticipated in providing benefits under a plan or program described in Section 1(b)(2)(B) of the Davis-Bacon Act, Contractor shall maintain records which show that the commitment to provide such benefits is enforceable, that the plan or program is financially responsible, and that the plan or program has been communicated in writing to the laborers or mechanics affected, and records which show the costs anticipated or the actual cost incurred in providing such benefits. If Contractor employs apprentices or trainees under approved programs, Contractor shall maintain written evidence of the registration of apprenticeship programs and certification of trainee programs, the registration of the apprentices and trainees, and the ratios and wage rates prescribed in the applicable programs.

(ii)(A) Contractor shall submit weekly for each week in which any work under the Contract is performed a copy of all payrolls to UTA for transmission to the FTA. The payrolls submitted shall set out accurately and completely all of the information required to be maintained under Section 5.5(a)(3)(i) of Regulations, 29 CFR Part 5. This information may be submitted in any form desired. Optional Form WH-347 is available for this purpose and may be purchased from the Superintendent of Documents (Federal Stock Number 029-005-00014-1), U.S. Government Printing Office, Washington, DC 20402. Contractor is responsible for the submission of copies of payrolls by all subcontractors.

(B) Each payroll submitted shall be accompanied by a "Statement of Compliance," signed by Contractor or subcontractor or his or her agent who pays or supervises the payment of the persons employed under the Contract and shall certify the following: That the payroll for the payroll period contains the information required to be maintained under Section 5.5(a)(3)(i) of Regulations, 29 CFR Part 5 and that such information is correct and complete:

(1) That each laborer or mechanic (including each helper, apprentice, and trainee) employed on the Contract during the payroll period has been paid the full weekly wages earned, without rebate, either directly or indirectly, and that no deductions have been made either directly or indirectly from the full wages earned, other than permissible deductions as set forth in Regulations, 29 CFR Part 3; and

(2) That each laborer or mechanic has been paid not less than the applicable wage rates and fringe benefits or cash equivalents for the classification of work performed, as specified in the applicable wage determination incorporated into the Contract.

(C) The weekly submission of a properly executed certification set forth on the reverse side of Optional Form WH-347 shall satisfy the requirement for submission of the "Statement of Compliance" required by paragraph (3)(ii)(B) of this section.

(D) The falsification of any of the above certifications may subject Contractor or subcontractor to civil or criminal prosecution under Section 1001 of title 18 and Section 231 of title 31 of the United States Code.

(iii) Contractor and any subcontractor shall make the records required under paragraph (3) of this section available for inspection, copying, or transcription by authorized representatives of the FTA or the Department of Labor, and shall permit such representatives to interview employees during working hours on the job. If Contractor or subcontractor fails to submit the required records or to make them available, the federal agency may, after written notice to Contractor, sponsor, applicant, or owner, take such action as may be necessary to cause the suspension of any further payment, advance, or guarantee of funds. Furthermore, failure to submit the required records upon request or to make such

records available may be grounds for debarment action pursuant to 29 CFR §5.12.

(4) **Apprentices and trainees** – (i) Apprentices – Apprentices will be permitted to work at less than the predetermined rate for the work they performed when they are employed pursuant to and individually registered in a bona fide apprenticeship program registered with the U.S. Department of Labor, Employment and Training Administration, Bureau of Apprenticeship and Training, or with a State Apprenticeship Agency recognized by the Bureau, or if a person is employed in his or her first 90 days of probationary employment as an apprentice in such an apprenticeship program, who is not individually registered in the program, but who has been certified by the Bureau of Apprenticeship and Training or a State Apprenticeship Agency (where appropriate) to be eligible for probationary employment as an apprentice. The allowable ratio of apprentices to journeymen on the job site in any craft classification shall not be greater than the ratio permitted to Contractor as to the entire work force under the registered program. Any worker listed on a payroll at an apprentice wage rate, who is not registered or otherwise employed as stated above, shall be paid not less than the applicable wage rate on the wage determination for the classification of work actually performed. In addition, any apprentice performing work on the job site in excess of the ratio permitted under the registered program shall be paid not less than the applicable wage rate on the wage determination for the work actually performed. Where Contractor is performing construction on a project in a locality other than that in which its program is registered, the ratios and wage rates (expressed in percentages of the journeyman's hourly rate) specified in Contractor's or subcontractor's registered program shall be observed. Every apprentice must be paid at not less than the rate specified in the registered program for the apprentice's level of progress, expressed as a percentage of the journeymen hourly rate specified in the applicable wage determination. Apprentices shall be paid fringe benefits in accordance with the provisions of the apprenticeship program. If the apprenticeship program does not specify fringe benefits, apprentices must be paid the full amount of fringe benefits listed on the wage determination for the applicable classification. If the Administrator of the Wage and Hour Division of the U.S. Department of Labor determines that a different practice prevails for the applicable apprentice classification, fringes shall be paid in accordance with that determination. In the event the Bureau of Apprenticeship and Training, or a State Apprenticeship Agency recognized by the Bureau, withdraws approval of an apprenticeship program, Contractor will no longer be permitted to utilize apprentices at less than the applicable predetermined rate for the work performed until an acceptable program is approved.

(ii) Trainees – Except as provided in 29 CFR 5.16, trainees will not be permitted to work at less than the predetermined rate for the work performed unless they are employed pursuant to and individually registered in a program which has received prior approval, evidenced by formal certification by the U.S. Department of Labor, Employment and Training Administration. The ratio of trainees to journeymen on the job site shall not be greater than permitted under the plan approved by the Employment and Training Administration. Every trainee must be paid at not less than the rate specified in the approved program for the trainee's level of progress, expressed as a percentage of the journeyman hourly rate specified in the applicable wage determination. Trainees shall be paid fringe benefits in accordance with the provisions of the trainee program. If the trainee program does not mention fringe benefits, trainees shall be paid the full amount of fringe benefits listed on the wage determination unless the Administrator of the Wage and Hour Division determines that there is an apprenticeship program associated with the corresponding journeyman wage rate on the wage determination which provides for less than full fringe benefits for apprentices. Any employee listed on the payroll at a trainee rate who is not registered and participating in a training plan approved by the Employment and Training Administration shall be paid not less than the applicable wage rate on the wage determination for the classification of work actually performed. In addition, any trainee performing work on the job site in excess of the ratio permitted under the registered program shall be paid not less than the applicable wage rate on the wage determination for the work actually performed. In the event the Employment and Training Administration withdraws approval of a training program, Contractor will no longer be permitted to utilize trainees at less than the applicable predetermined rate for the work performed until an acceptable program is approved.

(iii) Equal employment opportunity – The utilization of apprentices, trainees and journeymen under this part shall be in conformity with the equal employment opportunity requirements of Executive Order 11246, as amended, and 29 CFR Part 30.

(5) **Compliance with Copeland “Anti-Kickback” Act Requirements** – Contractor shall comply with the requirements of 29 CFR Part 3, which are incorporated by reference in the Contract. Contractor is prohibited from inducing, by any means, any person employed in the construction, completion, or repair of public work, to give up any part of the compensation to which he or she is otherwise entitled.

(6) **Subcontracts** – Contractor and any subcontractor shall insert in any subcontracts the clauses contained in 29 CFR

5.5(a)(1) through (10) and such other clauses as the FTA may by appropriate instructions require, and also a clause requiring the subcontractors to include these clauses in any lower tier subcontracts. Contractor shall be responsible for the compliance by any subcontractor or lower tier subcontractor with all the contract clauses in 29 CFR 5.5.

(7) Contract Termination: Debarment – A breach of the contract clauses in 29 CFR 5.5 may be grounds for termination of the Contract, and for debarment of Contractor as a contractor and a subcontractor as provided in 29 CFR 5.12.

(8) Compliance with Davis-Bacon and Related Act Requirements – All rulings and interpretations of the Davis-Bacon and Related Acts contained in 29 CFR Parts 1, 3, and 5 are herein incorporated by reference in the Contract.

(9) Disputes Concerning Labor Standards – Disputes arising out of the labor standards provisions of the Contract shall not be subject to the general disputes clause of the Contract. Such disputes shall be resolved in accordance with the procedures of the Department of Labor set forth in 29 CFR Parts 5, 6, and 7. Disputes within the meaning of this clause include disputes between Contractor (or any of its subcontractors) and the contracting agency, the U.S. Department of Labor, or the employees or their representatives.

(10) Certification of Eligibility – (i) By entering into the Contract, Contractor certifies that neither Contractor nor any person or firm who has an interest in Contractor's firm is a person or firm ineligible to be awarded Government contracts by virtue of Section 3(a) of the Davis-Bacon Act or 29 CFR 5.12(a)(1). (ii) No part of the Contract shall be subcontracted to any person or firm ineligible for award of a Government contract by virtue of Section 3(a) of the Davis-Bacon Act or 29 CFR 5.12(a)(1). (iii) The penalty for making false statements is prescribed in the U.S. Criminal Code, 18 USC 1001.

DEBARMENT AND SUSPENSION [Applicable Only to Contracts valued at more than \$25,000]

Contractor shall comply and facilitate compliance with U.S. DOT regulations, “Nonprocurement Suspension and Debarment,” 2 CFR Part 1200, which adopts and supplements the U.S. Office of Management and Budget (U.S. OMB) “Guidelines to Agencies on Governmentwide Debarment and Suspension (Nonprocurement),” 2 CFR Part 180. These provisions apply to each contract at any tier of \$25,000 or more, and to each contract at any tier for a federally required audit (irrespective of the Contract amount), and to each contract at any tier that must be approved by an FTA official irrespective of the Contract amount. As such, Contractor shall verify that its principals, affiliates, and subcontractors are eligible to participate in this federally funded contract and are not presently declared by any federal department or agency to be: (i) debarred from participation in any federally assisted award; (ii) suspended from participation in any federally assisted award; (iii) proposed for debarment from participation in any federally assisted award; (iv) declared ineligible to participate in any federally assisted award; (iv) voluntarily excluded from participation in any federally assisted award; and/or (v) disqualified from participation in any federally assisted award. By submitting a response to UTA’s solicitation for the Contract, Contractor has certified that the foregoing items (i) through (v) are true. The certification in this clause is a material representation of fact relied upon by UTA. If it is later determined by UTA that Contractor knowingly rendered an erroneous certification, in addition to other remedies available that may be available to UTA, the federal government may pursue available remedies, including but not limited to suspension and/or debarment. Contractor agrees to comply with the requirements of 2 CFR Part 180, subpart C, as supplemented by 2 CFR Part 1200, during the Contract term. Contractor further agrees to include a provision requiring such compliance in its lower tier covered transactions.

DISADVANTAGED BUSINESS ENTERPRISES

(1) **FTA Policy** – The Contract is subject to 49 CFR Part 26. Therefore, Contractor must satisfy the requirements for DBE participation as set forth herein. These requirements are in addition to all other equal opportunity employment requirements of the Contract. UTA shall make all determinations with regard to whether or not Contractor is in compliance with the requirements stated herein.

(2) **Nondiscrimination** – Neither Contractor nor any subcontractor shall discriminate on the basis of race, color, national origin, or sex in the performance of the Contract. Contractor shall carry out applicable requirements of 49 CFR Part 26 in the award and administration of FTA-assisted contracts. Failure by Contractor to carry out these requirements is a material breach of the Contract, which may result in the termination of the Contract or such other remedy as UTA deems appropriate, which may include, but is not limited to: (i) withholding monthly progress payments in whole or in part; (ii) assessing any liquidated damages as may be provided in the Contract; (iii) requiring Contractor to stand-down with respect to the Work (without an increase in the Contract cost or an adjustment to the

Contract schedule) until Contractor achieves compliance with respect to these requirements and/or (iv) disqualifying Contractor from future participation in UTA contracts.

(3) **DBE Goals and Good Faith Efforts** – The national goal for participation of Disadvantaged Business Enterprises (DBE) is 10%. No separate contract goal has been set for the Phase 1 construction Services Agreement. If UTA executes the Phase 2 Construction Services Amendment, a contract goal of 6% will apply to the Phase 2 work. If a separate contract goal for DBE participation has been established for the Contract, it is listed in the solicitation documents that have been incorporated into the Contract. Contractor is required to document sufficient DBE participation to meet the applicable goal. If Contractor is unable to meet the applicable goal, Contractor must alternatively document adequate good faith efforts to meet the DBE Goal. The types of actions that the UTA will consider as part of the Bidder/Officer's good faith efforts include, but are not limited to, the following: (i) Contractor's attendance at a pre-bid meeting (as applicable) scheduled by UTA to inform DBEs of subcontracting opportunities; (ii) advertisement of subcontracting opportunities in general circulation media, trade association publications, and minority-focus media; (iii) written notification to capable DBEs that their interest in the Contract is solicited; (iv) documentation of efforts to negotiate with DBEs for specific subcontracts including the names, addresses, and telephone numbers of DBEs that were contacted and the date(s) of contact, a description of the information provided to DBEs regarding the work to be performed and a statement explaining why additional agreements with DBEs were not reached; (v) for each DBE Contractor contacted but rejected as unqualified, the reason for Contractor's conclusion; (vi) documentation of efforts made to assist the DBEs contacted that needed assistance in obtaining required bonding or insurance; (vii) documentation of efforts to utilize the services of small business organizations, community and contractor groups to locate qualified DBEs; (viii) documentation of Contractor's efforts to break out Contract work items into economically feasible units in fields where there are available DBE firms to perform the work; (ix) evidence that adequate information was provided to interested DBEs about the plans, specifications and requirements of the Contract, and that such information was communicated in a timely manner; and (x) documentation of any efforts made to assist interested DBEs in obtaining necessary equipment, supplies, materials or related assistance or services.

(4) **Race-Neutral Procurements** – If no separate contract goal has been established, the successful bidder/officer will be required to report its DBE participation obtained through race-neutral means throughout the period of performance.

(5) **Verification of Compliance** – Contractor shall assist UTA in verifying compliance with the DBE requirements of the Contract by submitting status reports itemizing payments to all DBEs with each monthly request for payment. Upon Contract completion, Contractor shall submit a summary of payments, by subcontract, made to all subcontractors to UTA's Civil Rights Compliance Officer.

(6) **Prompt Payment of Subcontractors** – Contractor is required to pay all of its subcontractors performing work related to the Contract for satisfactory performance of that work no later than 30 days after Contractor's receipt of payment for that work from UTA. In addition, Contractor may not hold retainage from its subcontractors or must return any retainage payments to those subcontractors within 30 days after the subcontractor's work related to the Contract is satisfactorily completed or must return any retainage payments to those subcontractors within 30 days after incremental acceptance of the subcontractor's work by UTA and Contractor's receipt of the partial retainage payment related to the subcontractor's work. The failure to make prompt payment to subcontractors as required above shall constitute a material breach of the Contract and shall give rise to remedies including, without limitation, the Authority's right to withhold amounts payable to the Contract and make direct payments (including interest) to subcontractors.

(7) **Termination of a DBE Subcontractor** – Contractor shall not terminate any DBE subcontractor identified in the Contract (or Contractor's response to the Contract solicitation) without UTA's prior written consent. UTA may provide such written consent only if Contractor has good cause to terminate the DBE subcontractor. Before transmitting a request to terminate, Contractor shall give notice in writing to the DBE subcontractor of its intent to terminate and the basis for the termination. Contractor shall give the DBE subcontractor five days to respond to the notice and advise of the reasons why the DBE subcontractor believes there is not good cause to terminate the subcontract. When a subcontract with the DBE subcontractor is terminated or when a DBE subcontractor fails to complete its work on the Contract for any reason, Contractor shall make good faith efforts to find another DBE subcontractor to substitute for the original DBE subcontractor and immediately notify UTA in writing of its efforts to replace the original DBE subcontractor. These good faith efforts shall be directed at finding another DBE to perform

at least the same amount of work under the Contract as the DBE subcontractor whose subcontract was terminated, to the extent needed to meet the applicable goal.

ENERGY CONSERVATION

Contractor shall comply with mandatory standards and policies relating to energy efficiency, stated in the state energy conservation plan issued in compliance with the Energy Policy & Conservation Act.

FALSE STATEMENTS OR CLAIMS CIVIL AND CRIMINAL FRAUD

Contractor acknowledges that the provisions of the Program Fraud Civil Remedies Act of 1986, as amended, 31 USC 3801 et seq. and USDOT regulations, "Program Fraud Civil Remedies," 49 CFR 31, apply to its actions pertaining to this project. Upon execution of the Contract, Contractor certifies or affirms the truthfulness and accuracy of any statement it has made, it makes, it may make, or causes to be made, pertaining to the Contract or FTA assisted project for which the Contract work is being performed. In addition to other penalties that may be applicable, Contractor further acknowledges that if it makes, or causes to be made, a false, fictitious, or fraudulent claim, statement, submittal, or certification, the US Government reserves the right to impose the penalties of the Program Fraud Civil Remedies Act (1986) on

Contractor to the extent the US Government deems appropriate.

Contractor also acknowledges that if it makes, or causes to be made, a false, fictitious, or fraudulent claim, statement, submission, or certification to the federal government under the Contract, the federal government reserves the right to impose the penalties of 18 USC §1001 and 49 USC §5323(l) on Contractor, to the extent the federal government deems appropriate.

Contractor shall include the above two clauses in each subcontract financed in whole or in part with FTA assistance. The clauses shall not be modified, except to identify the subcontractor who will be subject to the provisions.

FLY AMERICA REQUIREMENTS [Applicable Only to Contracts Involving Transportation of Persons or Property, by Air between the U.S. and/or Places Outside the U.S.]

Contractor shall comply with 49 USC 40118 (the "Fly America" Act) in accordance with General Services Administration regulations 41 CFR 301-10, stating that recipients and subrecipients of federal funds and their contractors are required to use US Flag air carriers for US Government-financed international air travel and transportation of their personal effects or property, to the extent such service is available, unless travel by foreign air carrier is a matter of necessity, as defined by the Fly America Act. Contractor shall submit, if a foreign air carrier was used, an appropriate certification or memorandum adequately explaining why service by a US flag air carrier was not available or why it was necessary to use a foreign air carrier and shall, in any event, provide a certificate of compliance with the Fly America requirements. Contractor shall include the requirements of this section in all subcontracts that may involve international air transportation.

INCORPORATION OF FTA TERMS

The Contract includes certain Standard Terms and Conditions required by the FTA, whether or not expressly stated in the Contract. All FTA-required contractual provisions, as stated in 2 CFR Part 200 or FTA Circular 4220.1F, are hereby incorporated by reference. Anything to the contrary herein notwithstanding, all FTA mandated terms shall be deemed to control in the event of a conflict with other provisions contained in the Contract. Contractor shall not perform any act, fail to perform any act, or refuse to comply with any request that would cause UTA to be in violation of FTA terms and conditions.

LOBBYING [Applicable Only to Contracts valued at more than \$150,000]

Byrd Anti-Lobbying Amendment, 31 USC 1352, as amended by the Lobbying Disclosure Act of 1995, P.L. 104-65 [to be codified at 2 USC §1601, et seq.] – Contractors who apply or bid for an award of \$150,000 or more shall file the certification required by 49 CFR Part 20, "New Restrictions on Lobbying." Each tier certifies to the tier above

that it will not and has not used federal appropriated funds to pay any person or organization for influencing or attempting to influence an officer or employee of any agency, a member of Congress, officer or employee of Congress, or an employee of a member of Congress in connection with obtaining any federal contract, grant or any other award covered by 31 USC 1352. Each tier shall also disclose the name of any registrant under the Lobbying Disclosure Act of 1995 who has made lobbying contacts on its behalf with non-federal funds with respect to that federal contract, grant or award covered by 31 USC 1352. Such disclosures are forwarded from tier to tier up to UTA.

NO FEDERAL GOVERNMENT OBLIGATIONS TO THIRD PARTIES

UTA and Contractor acknowledge and agree that, notwithstanding any concurrence by the federal government in or approval of the solicitation or award of the underlying Contract, absent the express written consent by the federal government, the federal government is not a party to the Contract and shall not be subject to any obligations or liabilities to UTA, Contractor or any other party (whether or not a party to the Contract) pertaining to any matter resulting from the Contract. Contractor agrees to include the above clause in each subcontract financed in whole or in part with federal assistance provided by the FTA. It is further agreed that the clause shall not be modified, except to identify the subcontractor who will be subject to its provisions.

RECYCLED PRODUCTS

Contractor agrees to provide a preference for those products and services that conserve natural resources, protect the environment, and are energy efficient by complying with and facilitating compliance with Section 6002 of the Resource Conservation and Recovery Act, as amended, 42 USC §6962, and U.S. Environmental Protection Agency (U.S. EPA), “Comprehensive Procurement Guideline for Products Containing Recovered Materials,” 40 CFR Part 247.

RESOLUTION OF DISPUTES, BREACHES AND OTHER LITIGATION

UTA and Contractor intend to resolve all disputes under the Contract to the best of their abilities in an informal manner. To accomplish this end, the parties will attempt to resolve disputes through communications between their respective staffs, and, if resolution is not reached at that level, a procedure for review and action on such disputes by appropriate management level officials within UTA and Contractor’s organization.

Unless otherwise directed by UTA, Contractor shall continue performance under the Contract while matters in dispute are being resolved.

Unless the Contract provides otherwise, all claims, counterclaims, disputes and other matters in question between UTA and Contractor arising out of or relating to the Contract or its breach will be decided by alternative dispute resolution if the parties mutually agree, or in a court of competent jurisdiction within the State of Utah.

Duties and obligations imposed by the Contract and the rights and remedies available thereunder shall be in addition to and not a limitation of any duties, obligations, rights and remedies otherwise imposed or available by law. No action or failure to act by UTA or Contractor shall constitute a waiver of any right or duty afforded any of them under the Contract, nor shall any such action or failure to act constitute an approval of or acquiescence in any breach thereunder, except as may be specifically agreed in writing.

SEISMIC SAFETY [Applicable Only to Contracts Involving Construction of new buildings or additions to existing buildings]

Contractor agrees that any new building or addition to an existing building shall be designed and constructed in accordance with the standards required in USDOT Seismic Safety Regulations 49 CFR 41 and shall certify compliance to the extent required by the regulation. Contractor shall also ensure that all work performed under the Contract, including work performed by subcontractors, complies with the standards required by 49 CFR 41 and the certification of compliance issued on the project.

TERMINATION

Upon ten (10) days' written notice to Contractor, UTA may, for its convenience and without cause, elect to terminate the Contract. If UTA terminates the Contract for its convenience, UTA shall pay Contractor for that portion of the work performed up to the date of the notice of termination, plus Contractor's actual, reasonable and documented costs attributable to the termination, including those incurred to terminate applicable subcontracts and leases, but excluding consequential damages, which includes, but is not limited to, lost profits and/or opportunity costs associated with the terminated portion of the work.

If Contractor materially fails to perform any of its obligations under the Contract, and such failure is not cured within ten (10) days of written notice from UTA identifying the breach, then UTA may terminate the Contract by delivering to Contractor a Notice of Termination specifying the nature of the default. In such event, UTA may take over the work and complete it by contract or otherwise, and may take possession of and use any materials, appliances and equipment on the work site necessary for completing the work. Contractor and its sureties shall be liable for any damages to UTA resulting from Contractor's refusal or failure to complete the work within specified time, whether or not Contractor's right to proceed with the work is terminated. Notwithstanding the foregoing, no cure period shall be required if Contractor's default is due to its failure to satisfy any legal requirement concerning workplace safety or environmental compliance, or if Contractor's action(s) and/or omission(s) materially jeopardize safety.

Accept Terms of Clauses _____ Date _____ Company Name _____ Federal I.D. No. _____

Appendix A

UTA Bus RTI Signage Plans and Locations

UTAH TRANSIT AUTHORITY



BUS FACILITIES REAL TIME INFORMATION SIGNAGE

PROJECT LOCATIONS

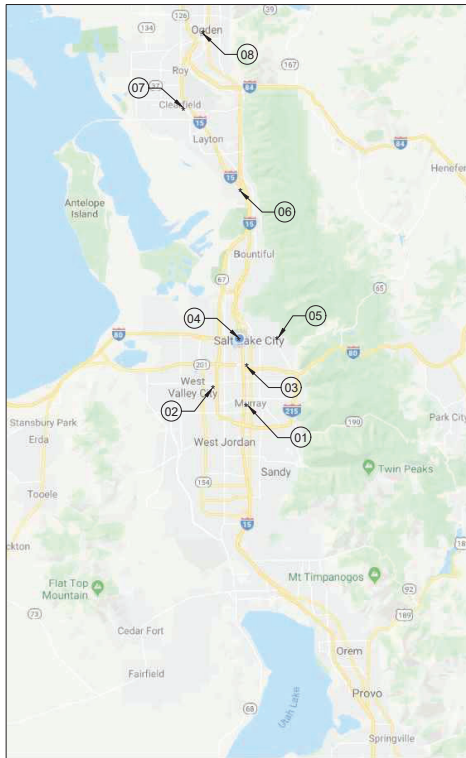

INDEX TO SHEETS	
SHEET NUMBER	DESCRIPTION
TITLE	TITLE SHEET
1	MURRAY CENTRAL STATION
2	WEST VALLEY CENTRAL STATION
3	CENTRAL POINTE STATION
4	SALT LAKE CENTRAL INTERMODAL
5	UNIVERSITY OF UTAH BUS LOOP
6	FARMINGTON STATION
7	CLEARFIELD STATION
8	OGDEN STATION
9	SIGN POST DETAILS 1 OF 2
10	SIGN POST DETAILS 2 OF 2
11	SIGN MOUNTING ARM DETAILS 1 OF 1
12	JUNCTION BOX DETAIL

REV	DATE	Description
△		
△		
△		
△	9/27/21	SIGN ATTACHMENT REVISION
△	8/6/21	RFP ADDENDUM #1

Submitted By: _____

Approved By: _____



Designed By:	XX
Drawn By:	XX
Checked By:	XX
Approved By:	XX

UTAH TRANSIT AUTHORITY
BUS FACILITIES
REAL TIME INFORMATION SIGNAGE

Scale:	
CADD Filename:	
Submital Date:	
UTA Contract No.:	
Drawing No.:	Sheet No.:
	TITLE



PLAN

NOTES

1. ALL MEASUREMENTS OF EXISTING CONDITIONS ARE APPROXIMATE AND SHALL BE VERIFIED IN FIELD BY CONTRACTOR.
2. LOCATIONS OF EXISTING UTILITIES ARE UNKNOWN AND SHALL BE LOCATED (BLUE STAKED) BY CONTRACTOR PRIOR TO BEGINNING OF CONSTRUCTION.
3. STOCKPILE AND REPLACE SOIL REMOVED DURING TRENCHING.
4. REPLACE SURFACE TREATMENT REMOVED BY TRENCHING (SOD, LANDSCAPE MULCH, SIDEWALK, ROADWAY, ETC) IN KIND. MATCH ALL EXISTING DEPTHS AND MATERIAL TYPES. SEAL ANY CONCRETE SAW CUT JOINTS WITH TYPE F1 JOINT FILLER MATERIAL PER APWA SECTION 32 13 73 (SIKAFLEX OR APPROVED EQUAL).
5. ANY VEGETATION, LANDSCAPING, OR IRRIGATION THAT IS DISTURBED DURING CONSTRUCTION SHALL BE REPLACED IN KIND BY CONTRACTOR.
6. REFER TO STRUCTURAL AND SIGNAGE DRAWINGS FOR SIGN AND POST INSTALLATION DETAILS.
7. CONFIRM SIGN ORIENTATION WITH UTA PRIOR TO INSTALLATION.
8. INSTALL JUNCTION BOX AT EACH SIGN LOCATION AND AS NEEDED FOR WIRE INSTALLATION. SEE JUNCTION BOX DETAIL.
9. INSTALL NETWORK CABLE IN A SEPARATE CONDUIT. REFER TO SIGN SPECIFICATIONS FOR CABLE REQUIREMENTS.
10. REFER TO SIGN SPECIFICATIONS FOR POWER REQUIREMENTS AND CONDUCTOR SIZING.
11. REFER TO PROJECT ENVIRONMENTAL DOCUMENT FOR EXCAVATION REQUIREMENTS. COORDINATE WITH UTA ENVIRONMENTAL, BUFFIE CHOURNOS, 801-287-3064.

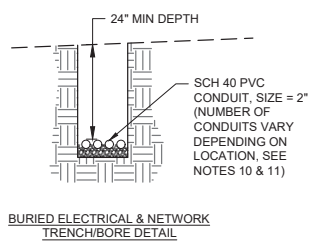
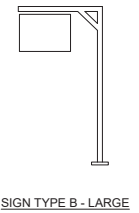
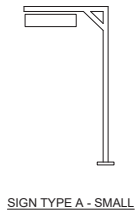

LEGEND

- BURIED CONDUIT (TRENCH/BORE)
- RTI SIGN TYPE A LOCATION
- RTI SIGN TYPE B LOCATION
- NETWORK ACCESS LOCATION
- POWER ACCESS LOCATION

△		
△		
△		
△		
△	8/6/21	RFP ADDENDUM #1
REV	DATE	Description

Submitted By: _____

Approved By: _____



Designed By:	XX
Drawn By:	XX
Checked By:	XX
Approved By:	XX

UTAH TRANSIT AUTHORITY
BUS FACILITIES
REAL TIME INFORMATION SIGNAGE
MURRAY CENTRAL STATION
5144 COTTONWOOD ST, MURRAY UT

Scale:	
CADD Filename:	
Submittal Date:	
UTA Contract No.:	
Drawing No.:	Sheet No.:
	1



SITE PHOTO



SITE PHOTO



PLAN

NOTES

1. ALL MEASUREMENTS OF EXISTING CONDITIONS ARE APPROXIMATE AND SHALL BE VERIFIED IN FIELD BY CONTRACTOR.
2. LOCATIONS OF EXISTING UTILITIES ARE UNKNOWN AND SHALL BE LOCATED (BLUE STAKED) BY CONTRACTOR PRIOR TO BEGINNING OF CONSTRUCTION.
3. STOCKPILE AND REPLACE SOIL REMOVED DURING TRENCHING.
4. REPLACE SURFACE TREATMENT REMOVED BY TRENCHING (SOD, LANDSCAPE MULCH, SIDEWALK, ROADWAY, ETC) IN KIND. MATCH ALL EXISTING DEPTHS AND MATERIAL TYPES.
5. SEAL ANY CONCRETE SAW CUT JOINTS WITH TYPE F1 JOINT FILLER MATERIAL PER APWA SECTION 32 13 73 (SIKAFLEX OR APPROVED EQUAL).
6. ANY VEGETATION, LANDSCAPING, OR IRRIGATION THAT IS DISTURBED DURING CONSTRUCTION SHALL BE REPLACED IN KIND BY CONTRACTOR.
7. REFER TO STRUCTURAL AND SIGNAGE DRAWINGS FOR SIGN AND POST INSTALLATION DETAILS.
8. CONFIRM SIGN ORIENTATION WITH UTA PRIOR TO INSTALLATION.
9. INSTALL JUNCTION BOX AT EACH SIGN LOCATION AND AS NEEDED FOR WIRE INSTALLATION. SEE JUNCTION BOX DETAIL.
10. INSTALL NETWORK CABLE IN A SEPARATE CONDUIT. REFER TO SIGN SPECIFICATIONS FOR CABLE REQUIREMENTS.
11. REFER TO SIGN SPECIFICATIONS FOR POWER REQUIREMENTS AND CONDUCTOR SIZING.

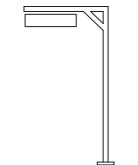

SIGN TYPE A - SMALL

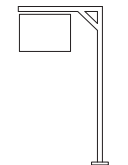

SIGN TYPE B - LARGE

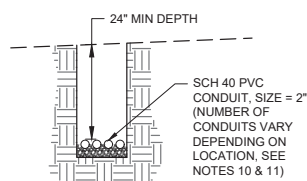

BURIED ELECTRICAL & NETWORK TRENCH/BORE DETAIL

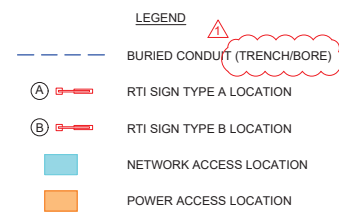

△		
△		
△		
△		
△	8/6/21	RFP ADDENDUM #1
REV	DATE	Description

Submitted By: _____



Approved By: _____

Designed By:	XX
Drawn By:	XX
Checked By:	XX
Approved By:	XX

UTAH TRANSIT AUTHORITY
 BUS FACILITIES
 REAL TIME INFORMATION SIGNAGE
 WEST VALLEY CENTRAL STATION
 2750 W 3590 S, WEST VALLEY CITY, UT

Scale:	
CADD Filename:	
Submital Date:	
UTA Contract No.:	
Drawing No.:	Sheet No.:
	2

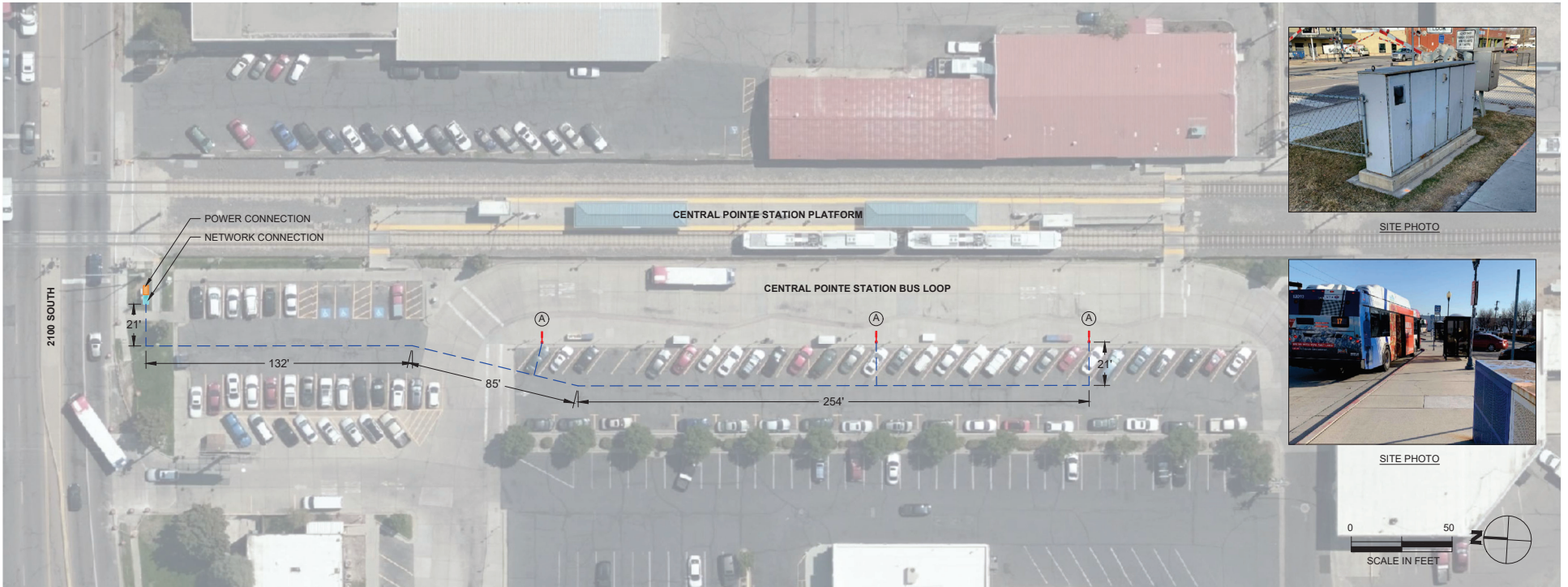

PLAN

NOTES

1. ALL MEASUREMENTS OF EXISTING CONDITIONS ARE APPROXIMATE AND SHALL BE VERIFIED IN FIELD BY CONTRACTOR.
2. LOCATIONS OF EXISTING UTILITIES ARE UNKNOWN AND SHALL BE LOCATED (BLUE STAKED) BY CONTRACTOR PRIOR TO BEGINNING OF CONSTRUCTION.
3. STOCKPILE AND REPLACE SOIL REMOVED DURING TRENCHING.
4. REPLACE SURFACE TREATMENT REMOVED BY TRENCHING (SOD, LANDSCAPE MULCH, SIDEWALK, ROADWAY, ETC) IN KIND. MATCH ALL EXISTING DEPTHS AND MATERIAL TYPES.
5. SEAL ANY CONCRETE SAW CUT JOINTS WITH TYPE F1 JOINT FILLER MATERIAL PER APWA SECTION 32 13 73 (SIKAFLEX OR APPROVED EQUAL).
6. ANY VEGETATION, LANDSCAPING, OR IRRIGATION THAT IS DISTURBED DURING CONSTRUCTION SHALL BE REPLACED IN KIND BY CONTRACTOR.
7. REFER TO STRUCTURAL AND SIGNAGE DRAWINGS FOR SIGN AND POST INSTALLATION DETAILS.
8. CONFIRM SIGN ORIENTATION WITH UTA PRIOR TO INSTALLATION.
9. INSTALL JUNCTION BOX AT EACH SIGN LOCATION AND AS NEEDED FOR WIRE INSTALLATION. SEE JUNCTION BOX DETAIL.
10. INSTALL NETWORK CABLE IN A SEPARATE CONDUIT. REFER TO SIGN SPECIFICATIONS FOR CABLE REQUIREMENTS.
11. REFER TO SIGN SPECIFICATIONS FOR POWER REQUIREMENTS AND CONDUCTOR SIZING.

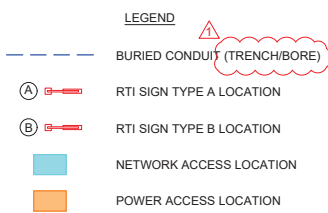
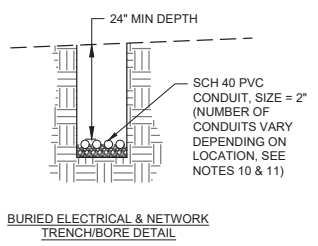
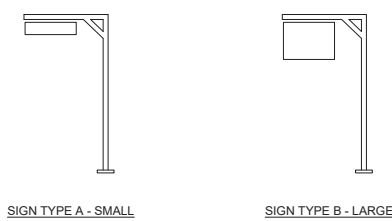

△		
△		
△		
△		
△	8/6/21	RFP ADDENDUM #1
REV	DATE	Description

Submitted By: _____

Approved By: _____



Designed By:	XX
Drawn By:	XX
Checked By:	XX
Approved By:	XX

UTAH TRANSIT AUTHORITY
BUS FACILITIES
REAL TIME INFORMATION SIGNAGE
CENTRAL POINTE STATION
221 W 2100 S, SALT LAKE CITY, UT

Scale:	
CADD Filename:	
Submittal Date:	
UTA Contract No.:	
Drawing No.:	Sheet No.:
	3

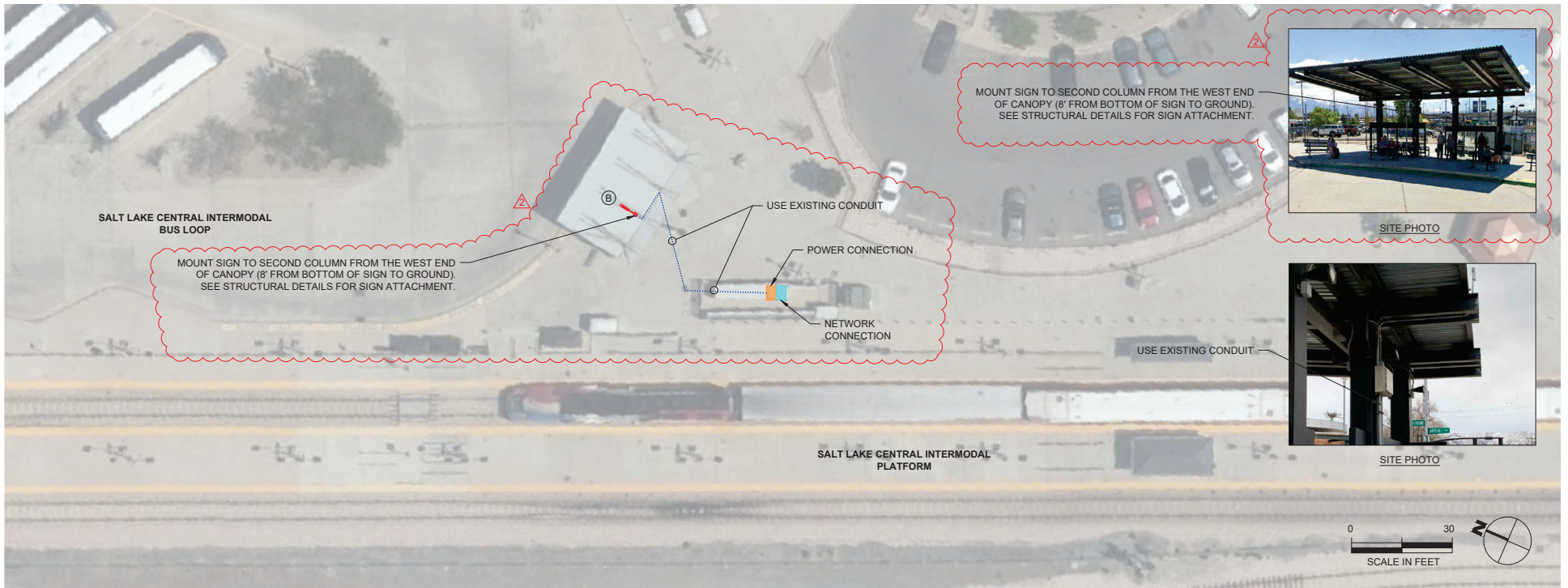

PLAN

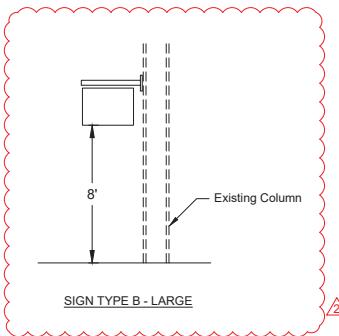

LEGEND

- EXISTING CONDUIT
- (A) RTI SIGN TYPE A LOCATION
- (B) RTI SIGN TYPE B LOCATION
- NETWORK ACCESS LOCATION
- POWER ACCESS LOCATION

NOTES

1. ALL MEASUREMENTS OF EXISTING CONDITIONS ARE APPROXIMATE AND SHALL BE VERIFIED IN FIELD BY CONTRACTOR.
2. LOCATIONS OF EXISTING UTILITIES ARE UNKNOWN AND SHALL BE LOCATED (BLUE STAKED) BY CONTRACTOR PRIOR TO BEGINNING OF CONSTRUCTION.
3. STOCKPILE AND REPLACE SOIL REMOVED DURING TRENCHING.
4. REPLACE SURFACE TREATMENT REMOVED BY TRENCHING (SOD, LANDSCAPE MULCH, SIDEWALK, ROADWAY, ETC) IN KIND. MATCH ALL EXISTING DEPTHS AND MATERIAL TYPES.
5. SEAL ANY CONCRETE SAW CUT JOINTS WITH TYPE F1 JOINT FILLER MATERIAL PER APWA SECTION 32 13 73 (SIKAFLEX OR APPROVED EQUAL).
6. ANY VEGETATION, LANDSCAPING, OR IRRIGATION THAT IS DISTURBED DURING CONSTRUCTION SHALL BE REPLACED IN KIND BY CONTRACTOR.
7. REFER TO STRUCTURAL AND SIGNAGE DRAWINGS FOR SIGN AND POST INSTALLATION DETAILS.
8. CONFIRM SIGN ORIENTATION WITH UTA PRIOR TO INSTALLATION.
9. INSTALL JUNCTION BOX AT EACH SIGN LOCATION AND AS NEEDED FOR WIRE INSTALLATION. SEE JUNCTION BOX DETAIL.
10. COORDINATE SIGN FOUNDATION AND JUNCTION BOX PLACEMENT WITH UTA FACILITIES.
11. INSTALL NETWORK CABLE IN A SEPARATE CONDUIT. REFER TO SIGN SPECIFICATIONS FOR CABLE REQUIREMENTS.
12. REFER TO SIGN SPECIFICATIONS FOR POWER REQUIREMENTS AND CONDUCTOR SIZING.
13. REFER TO PROJECT ENVIRONMENTAL DOCUMENT FOR EXCAVATION REQUIREMENTS. COORDINATE WORK WITH UTA ENVIRONMENTAL, BUFFIE CHOURNOS, 801-287-3064.

△		
△		
△		
△	9/27/21	SIGN ATTACHMENT REVISION
△	8/6/21	RFP ADDENDUM #1
REV	DATE	Description

Submitted By: _____

Approved By: _____



Designed By:	XX
Drawn By:	XX
Checked By:	XX
Approved By:	XX

UTAH TRANSIT AUTHORITY
BUS FACILITIES
REAL TIME INFORMATION SIGNAGE
SALT LAKE CENTRAL INTERMODAL
300 S 600 W, SALT LAKE CITY, UT

Scale:	
CADD Filename:	
Submital Date:	
UTA Contract No.:	
Drawing No.:	Sheet No.:
	4

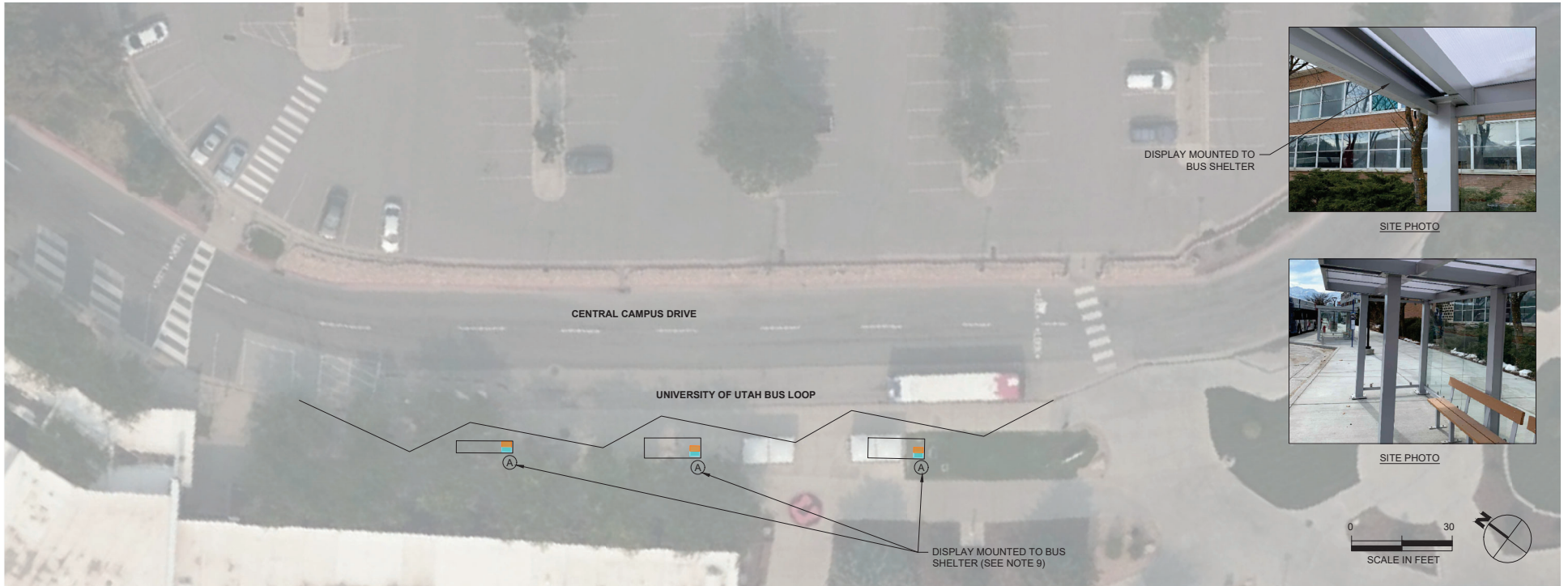

PLAN

NOTES

1. ALL MEASUREMENTS OF EXISTING CONDITIONS ARE APPROXIMATE AND SHALL BE VERIFIED IN FIELD BY CONTRACTOR.
2. LOCATIONS OF EXISTING UTILITIES ARE UNKNOWN AND SHALL BE LOCATED (BLUE STAKED) BY CONTRACTOR PRIOR TO BEGINNING OF CONSTRUCTION.
3. STOCKPILE AND REPLACE SOIL REMOVED DURING TRENCHING.
4. REPLACE SURFACE TREATMENT REMOVED BY TRENCHING (SOD, LANDSCAPE MULCH, SIDEWALK, ROADWAY, ETC) IN KIND. MATCH ALL EXISTING DEPTHS AND MATERIAL TYPES.
5. SEAL ANY CONCRETE SAW CUT JOINTS WITH TYPE F1 JOINT FILLER MATERIAL PER APWA SECTION 32 13 73 (SIKAFLEX OR APPROVED EQUAL).
6. ANY VEGETATION, LANDSCAPING, OR IRRIGATION THAT IS DISTURBED DURING CONSTRUCTION SHALL BE REPLACED IN KIND BY CONTRACTOR.
7. REFER TO STRUCTURAL AND SIGNAGE DRAWINGS FOR SIGN AND POST INSTALLATION DETAILS.
8. CONFIRM SIGN ORIENTATION WITH UTA PRIOR TO INSTALLATION.
9. POWER & NETWORK CONDUIT STUBBED TO EXISTING SHELTERS. SEE PROJECT DOCUMENTS FOR CONDUIT & MOUNTING LOCATIONS.

LEGEND

- BURIED CONDUIT
- (A) → RTI SIGN TYPE A LOCATION
- (B) → RTI SIGN TYPE B LOCATION
- NETWORK ACCESS LOCATION
- POWER ACCESS LOCATION

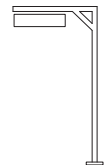

SIGN TYPE A - SMALL

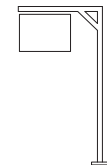

SIGN TYPE B - LARGE

△		
△		
△		
△		
△		
△		
REV	DATE	Description

Submitted By: _____

Approved By: _____



Designed By:	XX
Drawn By:	XX
Checked By:	XX
Approved By:	XX

UTAH TRANSIT AUTHORITY
 BUS FACILITIES
 REAL TIME INFORMATION SIGNAGE
 UNIVERSITY OF UTAH BUS LOOP
 200 S CENTRAL CAMPUS DR, SALT LAKE CITY, UT

Scale:	
CADD Filename:	
Submital Date:	
UTA Contract No.:	
Drawing No.:	Sheet No.:
	5

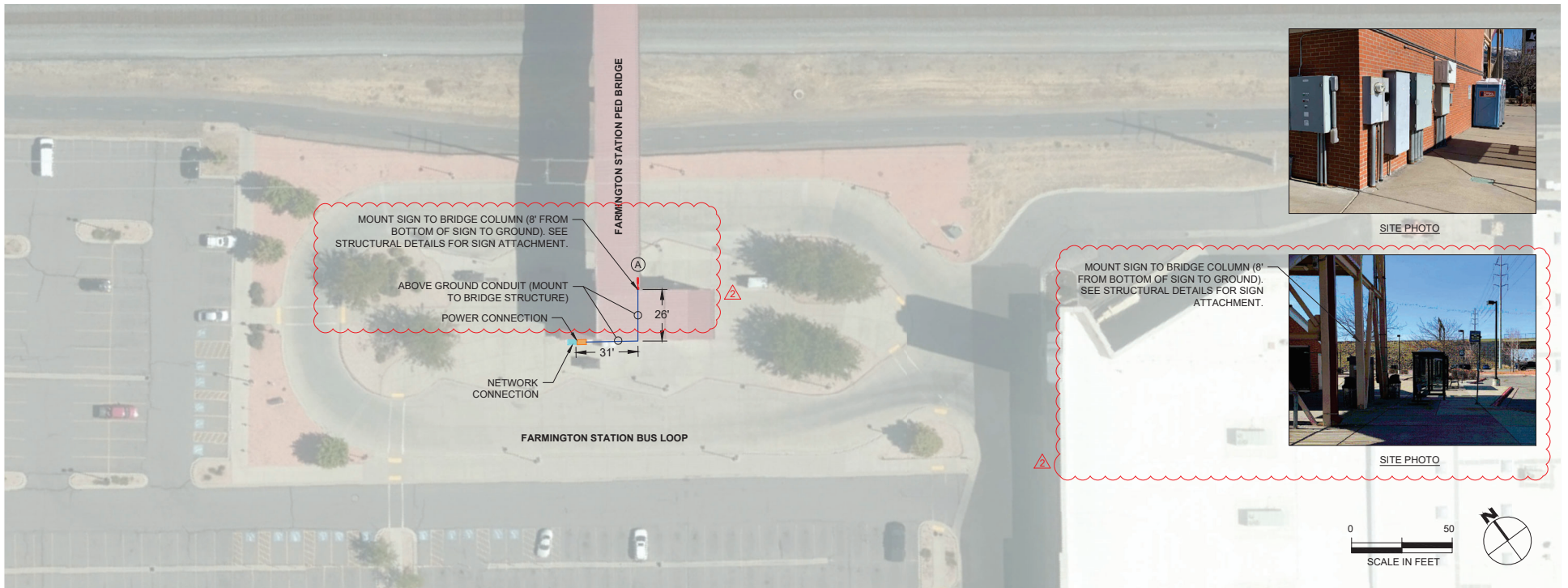

PLAN

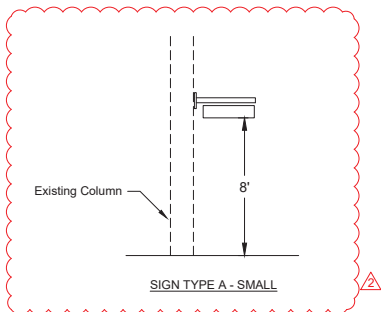

- LEGEND**
- BURIED CONDUIT (TRENCH/BORE)
 - ABOVE GROUND CONDUIT
 - A RTI SIGN TYPE A LOCATION
 - B RTI SIGN TYPE B LOCATION
 - NETWORK ACCESS LOCATION
 - POWER ACCESS LOCATION

NOTES

1. ALL MEASUREMENTS OF EXISTING CONDITIONS ARE APPROXIMATE AND SHALL BE VERIFIED IN FIELD BY CONTRACTOR.
2. LOCATIONS OF EXISTING UTILITIES ARE UNKNOWN AND SHALL BE LOCATED (BLUE STAKED) BY CONTRACTOR PRIOR TO BEGINNING OF CONSTRUCTION.
3. STOCKPILE AND REPLACE SOIL REMOVED DURING TRENCHING.
4. REPLACE SURFACE TREATMENT REMOVED BY TRENCHING (SOD, LANDSCAPE MULCH, SIDEWALK, ROADWAY, ETC) IN KIND. MATCH ALL EXISTING DEPTHS AND MATERIAL TYPES.
5. SEAL ANY CONCRETE SAW CUT JOINTS WITH TYPE F1 JOINT FILLER MATERIAL PER APWA SECTION 32 13 73 (SIKAFLEX OR APPROVED EQUAL).
6. ANY VEGETATION, LANDSCAPING, OR IRRIGATION THAT IS DISTURBED DURING CONSTRUCTION SHALL BE REPLACED IN KIND BY CONTRACTOR.
7. REFER TO STRUCTURAL AND SIGNAGE DRAWINGS FOR SIGN AND POST INSTALLATION DETAILS.
8. CONFIRM SIGN ORIENTATION WITH UTA PRIOR TO INSTALLATION.
9. INSTALL JUNCTION BOX AT EACH SIGN LOCATION AND AS NEEDED FOR WIRE INSTALLATION. SEE JUNCTION BOX DETAIL.
10. COORDINATE SIGN FOUNDATION AND JUNCTION BOX PLACEMENT WITH UTA FACILITIES. RUN CONDUIT ABOVE GROUND ALONG BRIDGE STRUCTURE.
11. INSTALL NETWORK CABLE IN A SEPARATE CONDUIT. REFER TO SIGN SPECIFICATIONS FOR CABLE REQUIREMENTS.
12. REFER TO SIGN SPECIFICATIONS FOR POWER REQUIREMENTS AND CONDUCTOR SIZING.

△		
△		
△		
△	9/27/21	SIGN ATTACHMENT REVISION
△	8/6/21	RFP ADDENDUM #1
REV	DATE	Description

Submitted By: _____

Approved By: _____



UTAH TRANSIT AUTHORITY

Designed By:	XX
Drawn By:	XX
Checked By:	XX
Approved By:	XX

UTAH TRANSIT AUTHORITY
BUS FACILITIES
REAL TIME INFORMATION SIGNAGE
FARMINGTON STATION
450 N 850 W, FARMINGTON, UT

Scale:	
CADD Filename:	
Submitted Date:	
UTA Contract No.:	
Drawing No.:	Sheet No.:
	6

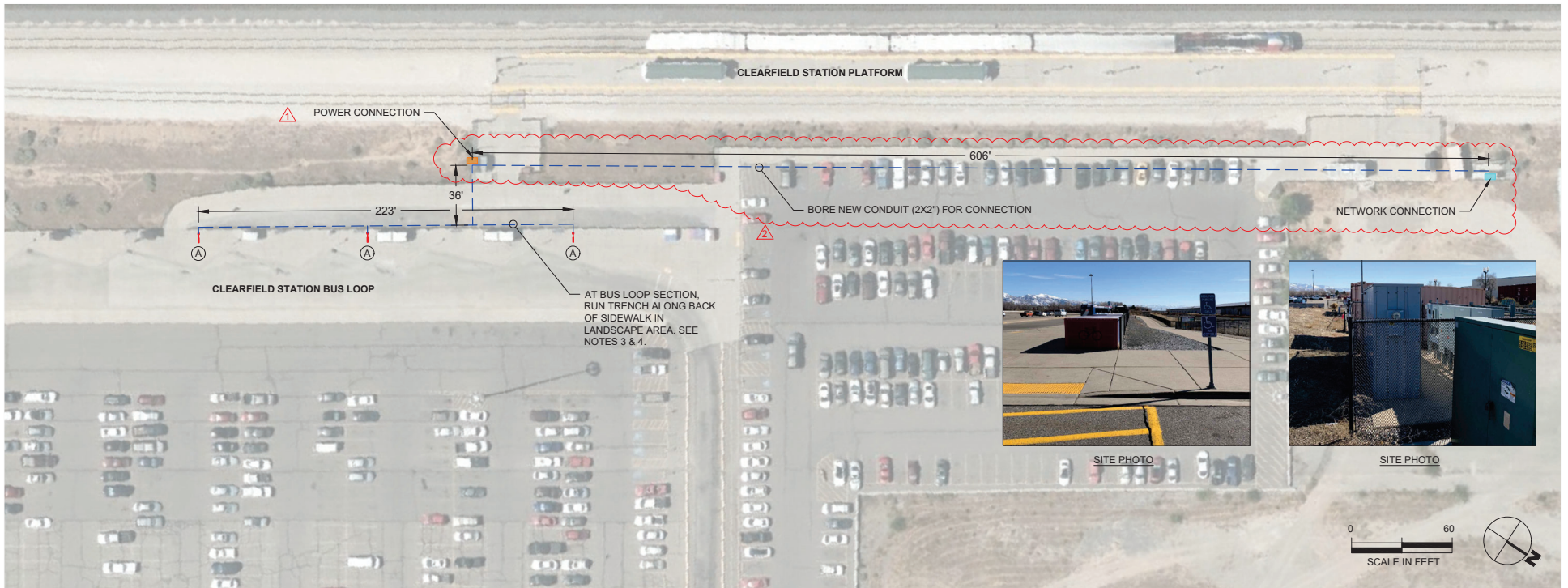

PLAN

NOTES

- ALL MEASUREMENTS OF EXISTING CONDITIONS ARE APPROXIMATE AND SHALL BE VERIFIED IN FIELD BY CONTRACTOR.
- LOCATIONS OF EXISTING UTILITIES ARE UNKNOWN AND SHALL BE LOCATED (BLUE STAKED) BY CONTRACTOR PRIOR TO BEGINNING OF CONSTRUCTION.
- STOCKPILE AND REPLACE SOIL REMOVED DURING TRENCHING.
- REPLACE SURFACE TREATMENT REMOVED BY TRENCHING (SOD, LANDSCAPE MULCH, SIDEWALK, ROADWAY, ETC) IN KIND. MATCH ALL EXISTING DEPTHS AND MATERIAL TYPES.
- SEAL ANY CONCRETE SAW CUT JOINTS WITH TYPE F1 JOINT FILLER MATERIAL PER APWA SECTION 32 13 73 (SIKAFLEX OR APPROVED EQUAL).
- ANY VEGETATION, LANDSCAPING, OR IRRIGATION THAT IS DISTURBED DURING CONSTRUCTION SHALL BE REPLACED IN KIND BY CONTRACTOR.
- REFER TO STRUCTURAL AND SIGNAGE DRAWINGS FOR SIGN AND POST INSTALLATION DETAILS.
- CONFIRM SIGN ORIENTATION WITH UTA PRIOR TO INSTALLATION.
- INSTALL JUNCTION BOX AT EACH SIGN LOCATION AND AS NEEDED FOR WIRE INSTALLATION. SEE JUNCTION BOX DETAIL.
- INSTALL NETWORK CABLE IN A SEPARATE CONDUIT. REFER TO SIGN SPECIFICATIONS FOR CABLE REQUIREMENTS.
- REFER TO SIGN SPECIFICATIONS FOR POWER REQUIREMENTS AND CONDUCTOR SIZING.

LEGEND

- EXISTING CONDUIT
- - - - - BURIED CONDUIT (TRENCH/BORE)
- (A) RTI SIGN TYPE A LOCATION
- (B) RTI SIGN TYPE B LOCATION
- NETWORK ACCESS LOCATION
- POWER ACCESS LOCATION

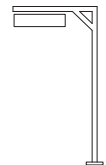

SIGN TYPE A - SMALL

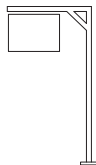

SIGN TYPE B - LARGE

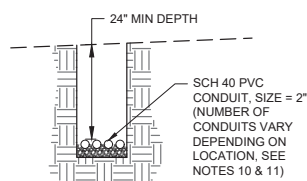

BURIED ELECTRICAL & NETWORK TRENCH/BORE DETAIL

△		
△		
△		
△	9/27/21	SIGN ATTACHMENT REVISION
△	8/6/21	RFP ADDENDUM #1
REV	DATE	Description

Submitted By: _____

Approved By: _____



UTAH TRANSIT AUTHORITY

Designed By:	XX
Drawn By:	XX
Checked By:	XX
Approved By:	XX

UTAH TRANSIT AUTHORITY
 BUS FACILITIES
 REAL TIME INFORMATION SIGNAGE
 CLEARFIELD STATION
 1250 S STATE ST, CLEARFIELD, UT

Scale:	
CADD Filename:	
Submittal Date:	
UTA Contract No.:	
Drawing No.:	Sheet No.:
	7

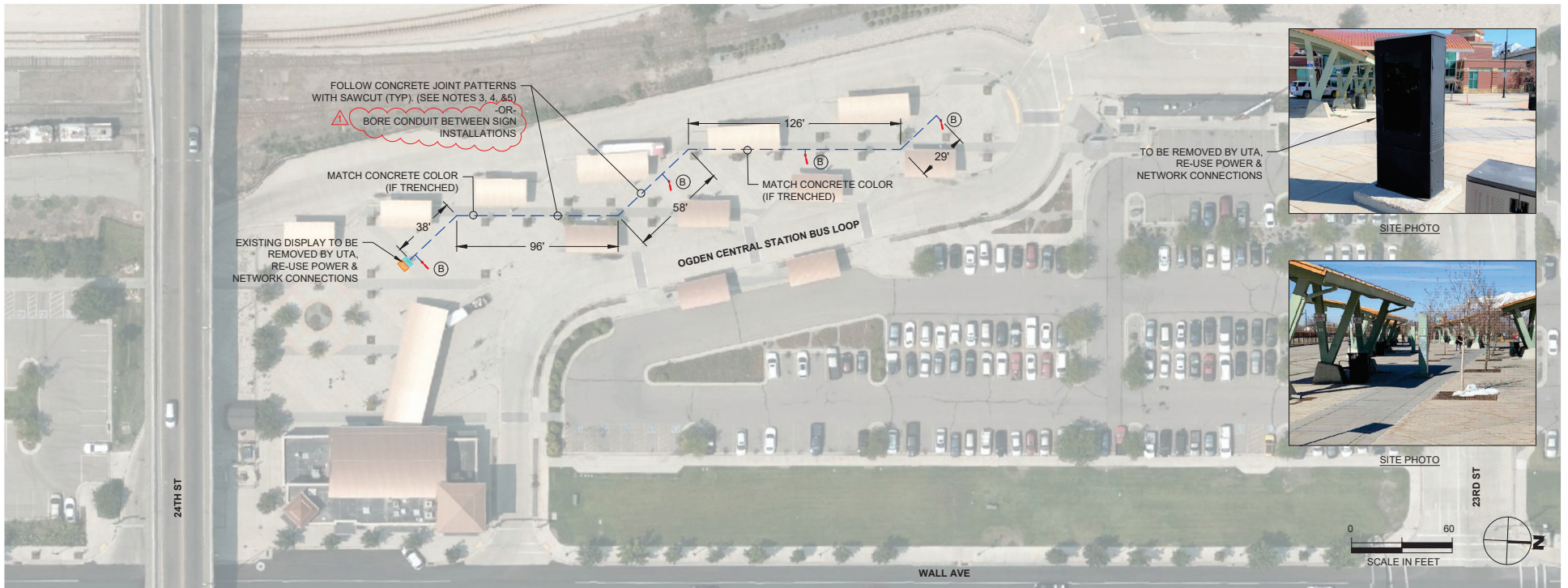

SITE PHOTO



SITE PHOTO



PLAN

NOTES

1. ALL MEASUREMENTS OF EXISTING CONDITIONS ARE APPROXIMATE AND SHALL BE VERIFIED IN FIELD BY CONTRACTOR.
2. LOCATIONS OF EXISTING UTILITIES ARE UNKNOWN AND SHALL BE LOCATED (BLUE STAKED) BY CONTRACTOR PRIOR TO BEGINNING OF CONSTRUCTION.
3. STOCKPILE AND REPLACE SOIL REMOVED DURING TRENCHING.
4. REPLACE SURFACE TREATMENT REMOVED BY TRENCHING (SOD, LANDSCAPE MULCH, SIDEWALK, ROADWAY, ETC) IN KIND. MATCH ALL EXISTING DEPTHS AND MATERIAL TYPES.
5. SEAL ANY CONCRETE SAW CUT JOINTS WITH TYPE F1 JOINT FILLER MATERIAL PER APWA SECTION 32 13 73 (SIKAFLEX OR APPROVED EQUAL).
6. ANY VEGETATION, LANDSCAPING, OR IRRIGATION THAT IS DISTURBED DURING CONSTRUCTION SHALL BE REPLACED IN KIND BY CONTRACTOR.
7. REFER TO STRUCTURAL AND SIGNAGE DRAWINGS FOR SIGN AND POST INSTALLATION DETAILS.
8. CONFIRM SIGN ORIENTATION WITH UTA PRIOR TO INSTALLATION.
9. INSTALL JUNCTION BOX AT EACH SIGN LOCATION AND AS NEEDED FOR WIRE INSTALLATION. SEE JUNCTION BOX DETAIL.
10. INSTALL NETWORK CABLE IN A SEPARATE CONDUIT. REFER TO SIGN SPECIFICATIONS FOR CABLE REQUIREMENTS.
11. REFER TO SIGN SPECIFICATIONS FOR POWER REQUIREMENTS AND CONDUCTOR SIZING.

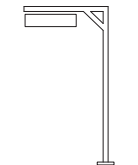

SIGN TYPE A - SMALL

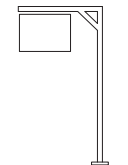

SIGN TYPE B - LARGE

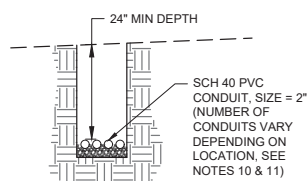

BURIED ELECTRICAL & NETWORK TRENCH/BORE DETAIL

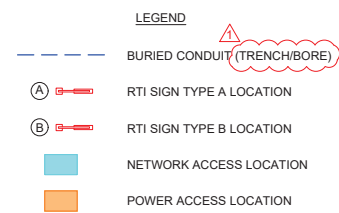

△		
△		
△		
△		
△	8/6/21	RFP ADDENDUM #1
REV	DATE	Description

Submitted By: _____

Submitted By: _____ Approved By: _____

Designed By:	XX
Drawn By:	XX
Checked By:	XX
Approved By:	XX

UTAH TRANSIT AUTHORITY
BUS FACILITIES
REAL TIME INFORMATION SIGNAGE
OGDEN CENTRAL STATION
2350 WALL AVE, OGDEN, UT

Scale:	
CADD Filename:	
Submital Date:	
UTA Contract No.:	
Drawing No.:	Sheet No.:
	8

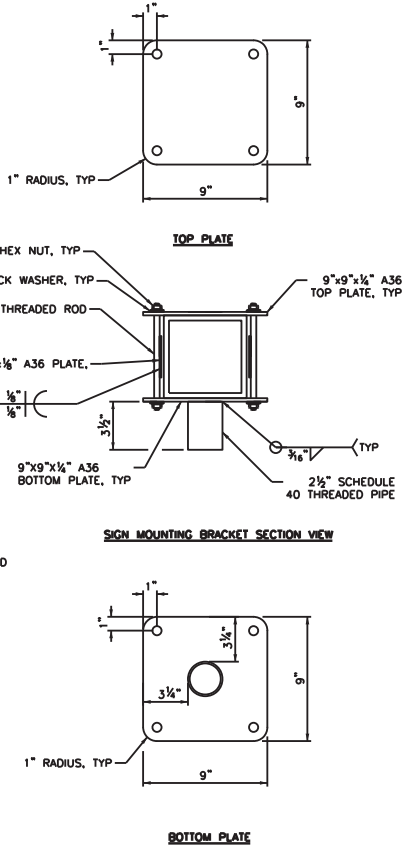
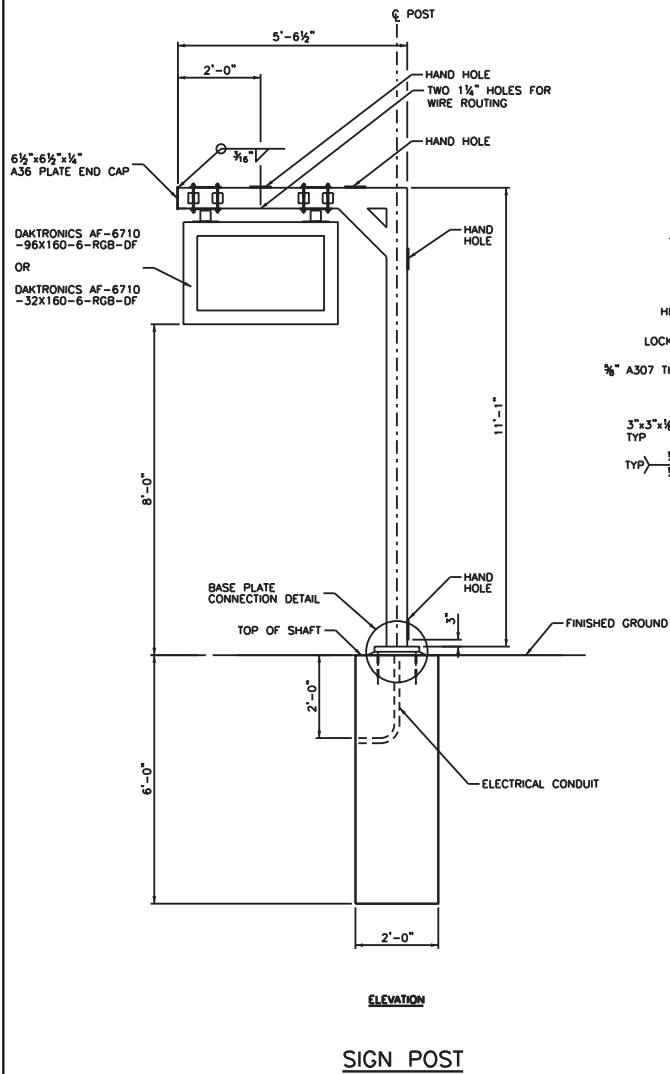

SIGN MOUNTING BRACKET

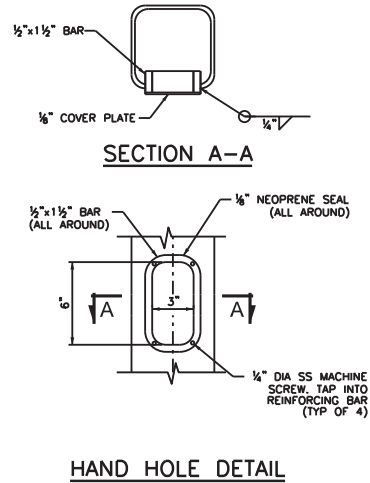

DESIGN DATA

LOADING IN ACCORDANCE WITH AASHTO LRFD STANDARD SPECIFICATIONS FOR STRUCTURAL SUPPORTS FOR HIGHWAY SIGNS, LUMINAIRES AND TRAFFIC SIGNALS, 6th EDITION.

WIND LOAD:	55 PSF
DEAD LOAD:	300 LBS MAX
SIGN BOX:	4'-0" x 2'-6" MAX SIGN SIZE
LIVE LOAD:	200 LBS
USE FATIGUE CATEGORY III	
STRUCTURAL STEEL:	F _y = 36 KSI (PLATES) F _y = 46 ksi (HSS SHAPE)
REINFORCING STEEL:	GR. 60
CAST-IN-PLACE CONCRETE:	f' _c = 4.0 KSI

NOTES

- WELD ACCORDING TO THE CURRENT EDITION OF THE ANSI/AWS D1.1 STRUCTURAL WELDING CODE (STEEL).
- GALVANIZE ALL NUTS, BOLTS AND WASHERS ACCORDING TO ASTM F2329.
- GALVANIZE ALL OTHER STEEL ITEMS ACCORDING TO ASTM A123 AND PROVIDE DRAIN HOLES AS REQUIRED.
- POWDER COAT ALL EXPOSED SURFACES, INCLUDING ANCHOR BOLTS AND BOLTING HARDWARE, ACCORDING TO ASTM D7803. UTA WILL SPECIFY FINISH COLOR.
- SUBMIT SHOP DRAWINGS FOR ALL SIGN POSTS AND MOUNTING ARMS TO THE ENGINEER FOR APPROVAL.
- ELECTRICIAN WILL SELECT CONDUIT SIZE.

REV	DATE	Description

Submitted By: _____

Approved By: _____



Designed By:
R. TEGATZ
Drawn By:
A. ALJAGIC
Checked By:
C. VANEK
Approved By:

SIGN POST DETAILS 1 OF 2

Scale:	
CADD Filename:	NONE
Submitter Date:	
UTA Contract No.:	
Drawing No.:	XX-XX
Sheet No.:	9

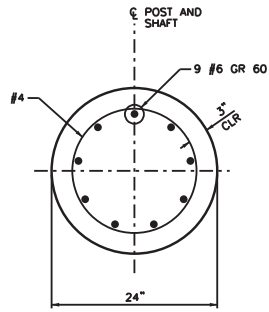

SECTION A-A

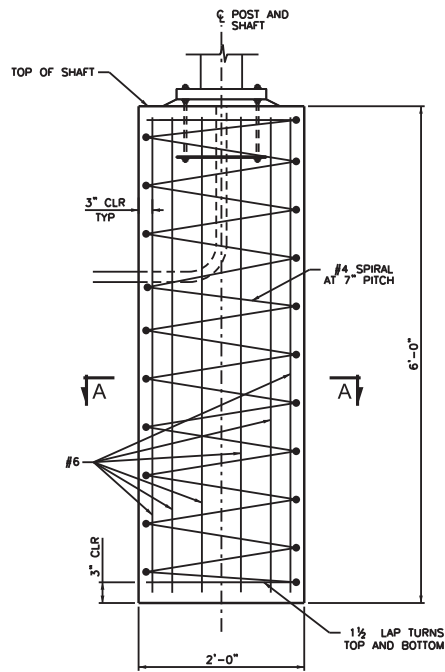

SIGN FOUNDATION

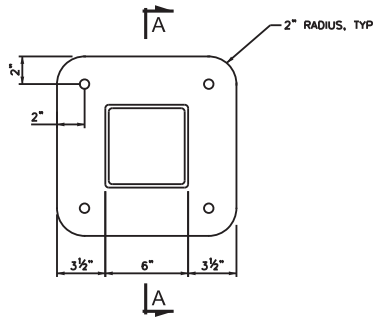

PLAN

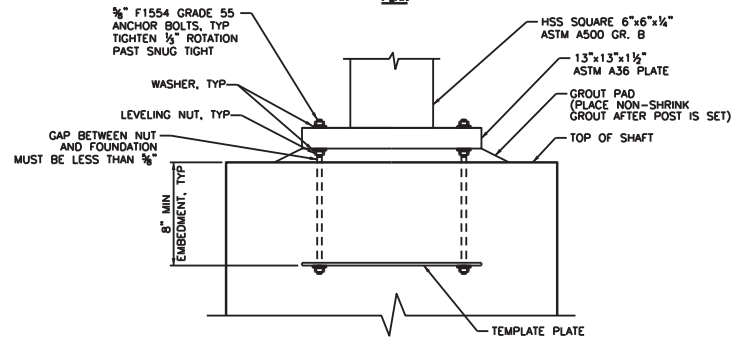

BASE PLATE CONNECTION DETAIL

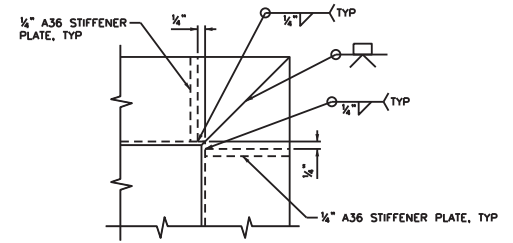

CORNER STIFFENER PLATE DETAIL

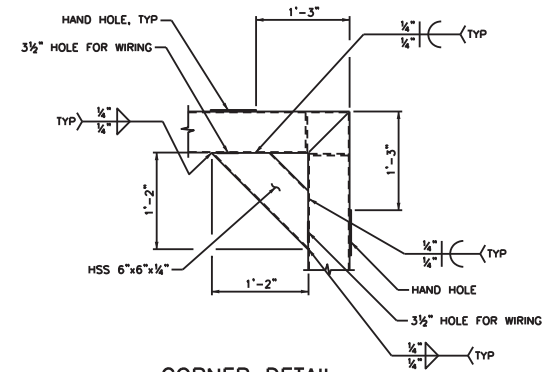

CORNER DETAIL

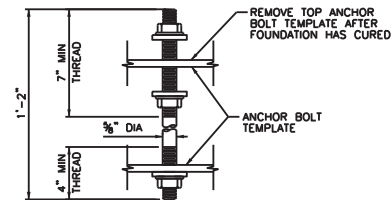

ANCHOR BOLT

△		
△		
△		
△		
△		
REV	DATE	Description

Submitted By: _____

Approved By: _____

UTA

UTAH TRANSIT AUTHORITY

Designed By: R. TEGATZ
Drawn By: A. ALJAGIC
Checked By: C. VANEK
Approved By:

SIGN POST DETAILS 2 OF 2

Scale:	
CADD Filename:	NONE
Submitor Date:	
UTA Contract No.:	
Drawing No.:	XX-XX
Sheet No.:	10

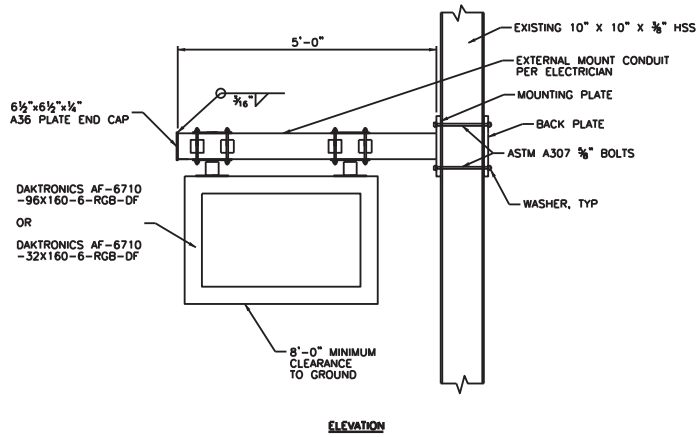

ELEVATION

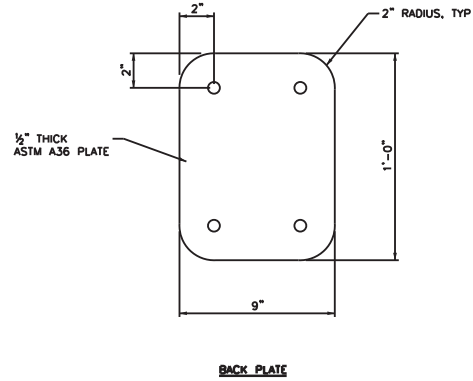

BACK PLATE

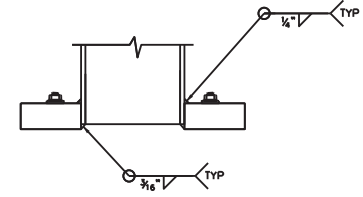

SECTION A-A

FARMINGTON SIGN STRUCTURE MOUNTING ARM

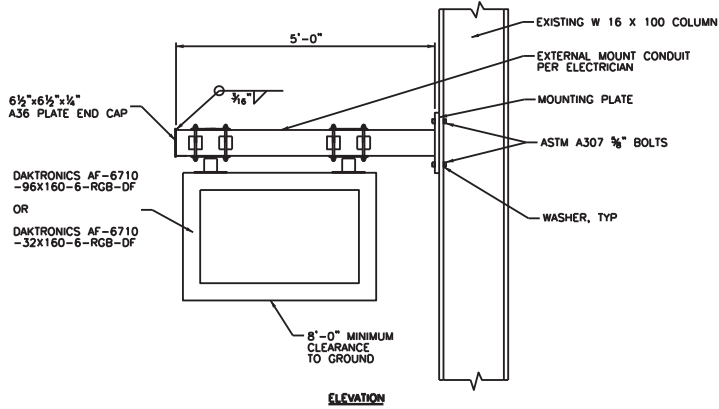

ELEVATION

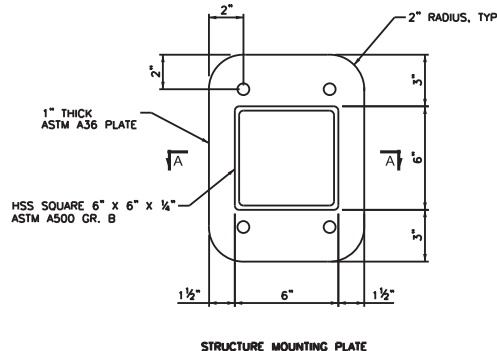

STRUCTURE MOUNTING PLATE

SALT LAKE CENTRAL SIGN STRUCTURE MOUNTING ARM

△		
△		
△		
△		
△		
△		
REV	DATE	Description

Submitted By: _____

Approved By: _____



Designed By:	R, TEGATZ
Drawn By:	A, ALLJAGIC
Checked By:	C, VANEK
Approved By:	

SIGN MOUNTING ARM DETAILS 1 OF 1

Scale:	
CADD Filename:	NONE
Submitter Date:	
UTA Contract No.:	
Drawing No.:	XX-XX
Sheet No.:	11

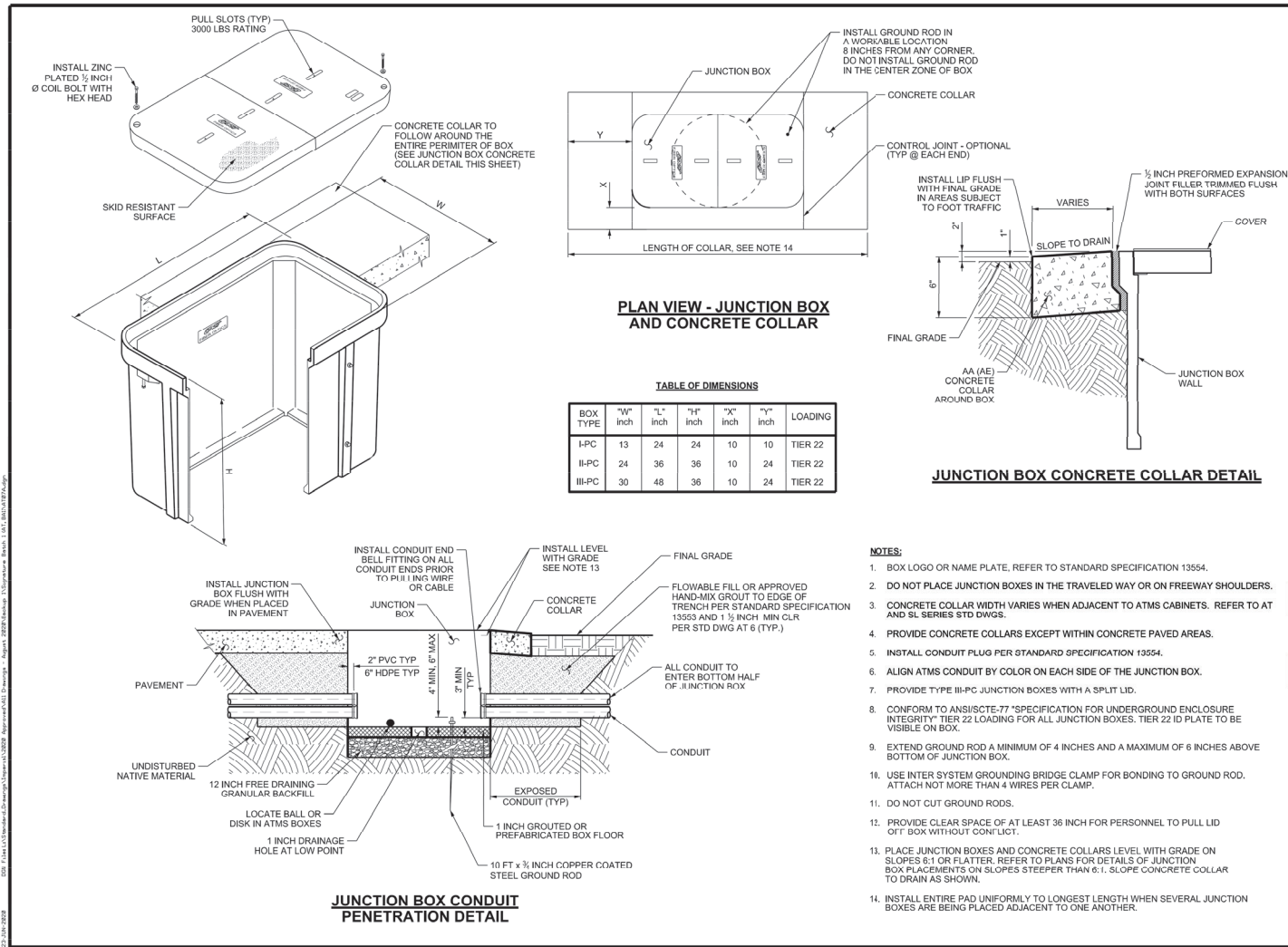

- NOTES:**
- BOX LOGO OR NAME PLATE. REFER TO STANDARD SPECIFICATION 13554.
 - DO NOT PLACE JUNCTION BOXES IN THE TRAVELED WAY OR ON FREEWAY SHOULDERS.
 - CONCRETE COLLAR WIDTH VARIES WHEN ADJACENT TO ATMS CABINETS. REFER TO AT AND SL SERIES STD DWGS.
 - PROVIDE CONCRETE COLLARS EXCEPT WITHIN CONCRETE PAVED AREAS.
 - INSTALL CONDUIT PLUG PER STANDARD SPECIFICATION 13554.
 - ALIGN ATMS CONDUIT BY COLOR ON EACH SIDE OF THE JUNCTION BOX.
 - PROVIDE TYPE III-PC JUNCTION BOXES WITH A SPLIT LID.
 - CONFORM TO ANSISCTE-77 "SPECIFICATION FOR UNDERGROUND ENCLOSURE INTEGRITY" TIER 22 LOADING FOR ALL JUNCTION BOXES. TIER 22 ID PLATE TO BE VISIBLE ON BOX.
 - EXTEND GROUND ROD A MINIMUM OF 4 INCHES AND A MAXIMUM OF 6 INCHES ABOVE BOTTOM OF JUNCTION BOX.
 - USE INTER SYSTEM GROUNDING BRIDGE CLAMP FOR BONDING TO GROUND ROD. ATTACH NOT MORE THAN 4 WIRES PER CLAMP.
 - DO NOT CUT GROUND RODS.
 - PROVIDE CLEAR SPACE OF AT LEAST 36 INCH FOR PERSONNEL TO PULL LID OFF BOX WITHOUT CONFLICT.
 - PLACE JUNCTION BOXES AND CONCRETE COLLARS LEVEL WITH GRADE ON SLOPES 8:1 OR FLATTER. REFER TO PLANS FOR DETAILS OF JUNCTION BOX PLACEMENTS ON SLOPES STEEPER THAN 6:1. SLOPE CONCRETE COLLAR TO DRAIN AS SHOWN.
 - INSTALL ENTIRE PAD UNIFORMLY TO LONGEST LENGTH WHEN SEVERAL JUNCTION BOXES ARE BEING PLACED ADJACENT TO ONE ANOTHER.

UTAH DEPARTMENT OF TRANSPORTATION
STANDARD DRAWINGS FOR ROAD AND BRIDGE CONSTRUCTION
SALT LAKE CITY, UTAH

DESIGNED BY: [Signature]
CHECKED BY: [Signature]
APPROVED BY: [Signature]

DATE: AUGUST 2020
DATE: AUGUST 2020
DATE: [Blank]

STANDARD DRAWING TITLE
POLYMER CONCRETE JUNCTION BOX DETAILS

STD. DWG. NO.
AT 7A

4/30/2020 MAX. ADDED OPTIONAL TO CONCRETE COLLAR DETAIL

REFERENCE DRAWING

△		
△		
△		
△		
△		
REV	DATE	Description

Submitted By: _____

Approved By: _____

UTA
UTAH TRANSIT AUTHORITY

Designed By: XX
Drawn By: XX
Checked By: XX
Approved By: XX

UTAH TRANSIT AUTHORITY
BUS FACILITIES
REAL TIME INFORMATION SIGNAGE
JUNCTION BOX DETAIL

Scale:	
CADD Filename:	
Submitted Date:	
UTA Contract No.:	
Drawing No.:	Sheet No.:
	12