

UTA Board of Trustees Meeting

July 13, 2022



Call to Order and Opening Remarks



Pledge of Allegiance



Safety First Minute



In Memoriam: Candice Hamilton



Candice Hamilton



In Memoriam: Andrew Fetzer



Andrew Fetzer passed away unexpectedly on June 29, 2022. He was 45 years old. Andrew loved his dog, his family, his girlfriend, and UTA. Andrew was a quiet, gentle soul; a friend to all, loved by all, held forever in our hearts.

UTAH TRANSIT AUTHORITY



Public Comment

Live comments are limited to 3 minutes per commenter

Public comment was solicited prior to the meeting through alternate means, including email, telephone, and the UTA website

Any comments received through alternate means were distributed to the board for review in advance of the meeting



Consent Agenda

- a. Approval of June 22, 2022 Board Meeting Minutes
- b. 2021 UTA Annual Comprehensive Financial Report (ACFR) and National Transit Database (NTD) Agreed Upon Procedure Report



Recommended Action **(by acclamation)**

Motion to approve consent agenda



Reports



Executive Director's Report



Financial Report – May 2022



Operating



UTA Board Dashboard

May 2022

UTAH TRANSIT AUTHORITY

Financial Metrics	Fav/ (Unfav) %				Fav/ (Unfav) %			
	May Actual	May Budget			YTD Actual	YTD Budget		
Sales Tax (Apr '22 mm \$)	\$ 42.7	\$ 35.9	\$ 6.85	19.1%	\$ 154.9	\$ 132.2	\$ 22.71	17.2%
Fare Revenue (mm)	\$ 2.9	\$ 2.7	\$ 0.18	6.6%	\$ 14.0	\$ 14.0	\$ 0.02	0.1%
Operating Exp (mm)	\$ 27.4	\$ 29.1	1.67	5.7%	\$ 134.8	\$ 147.0	\$ 12.22	8.3%
Subsidy Per Rider (SPR)	\$ 9.80	\$ 13.25	\$ 3.45	26.0%	\$ 9.70	\$ 13.25	\$ 3.55	26.8%
UTA Diesel Price (\$/gal)	\$ 4.58	\$ 2.75	\$ (1.83)	-66.6%	\$ 3.71	\$ 2.75	\$ (0.96)	-34.8%
Operating Metrics	May Actual	May-21	F/ (UF)	%	YTD Actual	YTD 2021	F/ (UF)	%
Ridership (mm)	2.50	1.77	0.7	41.3%	12.45	8.67	3.8	43.7%
Alternative Fuels	CNG Price (Diesel Gal Equiv)		\$ 1.82					

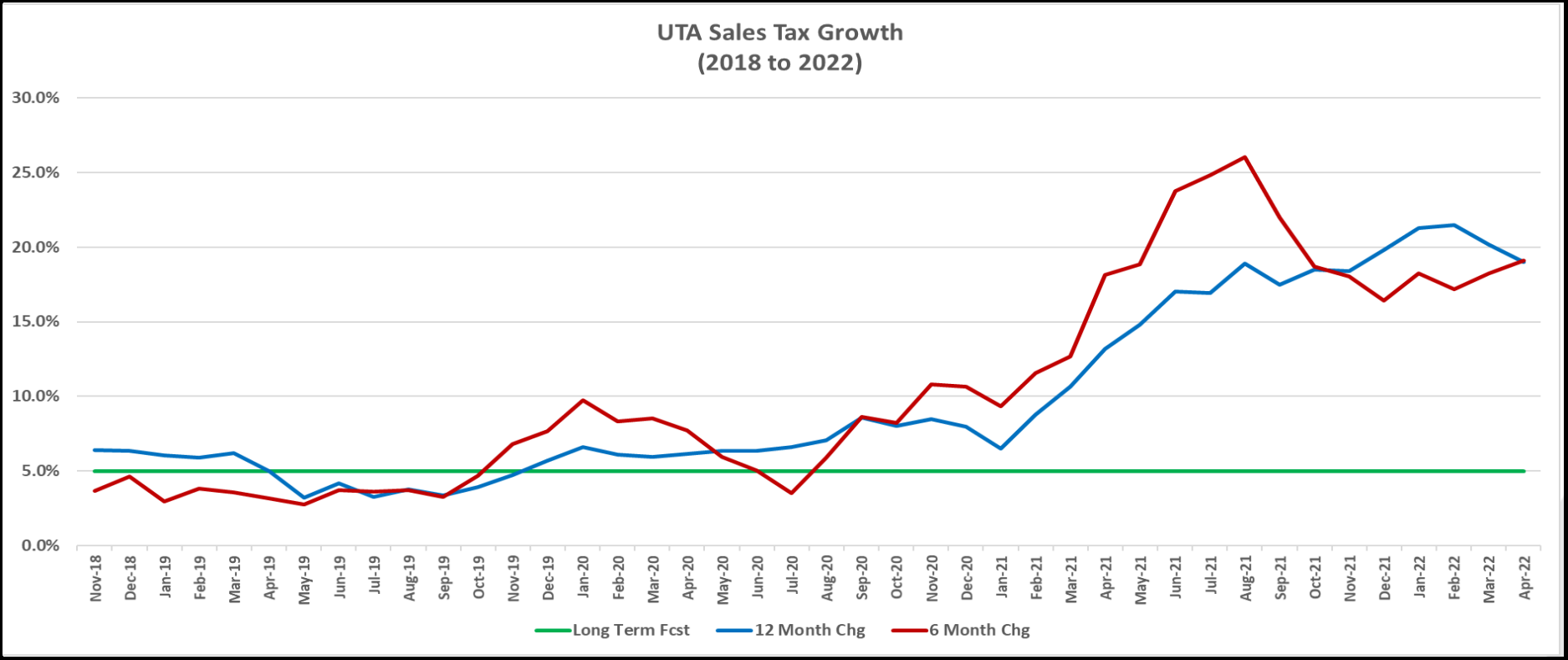

Sales Tax

- 2021 Actual
- Mo Budget
- Mo Actuals
- Cum Budget
- Cum Actual
- Cum 2021

UTAH TRANSIT AUTH

2022 Sales Tax April (YTD Variance +\$22.7 million)

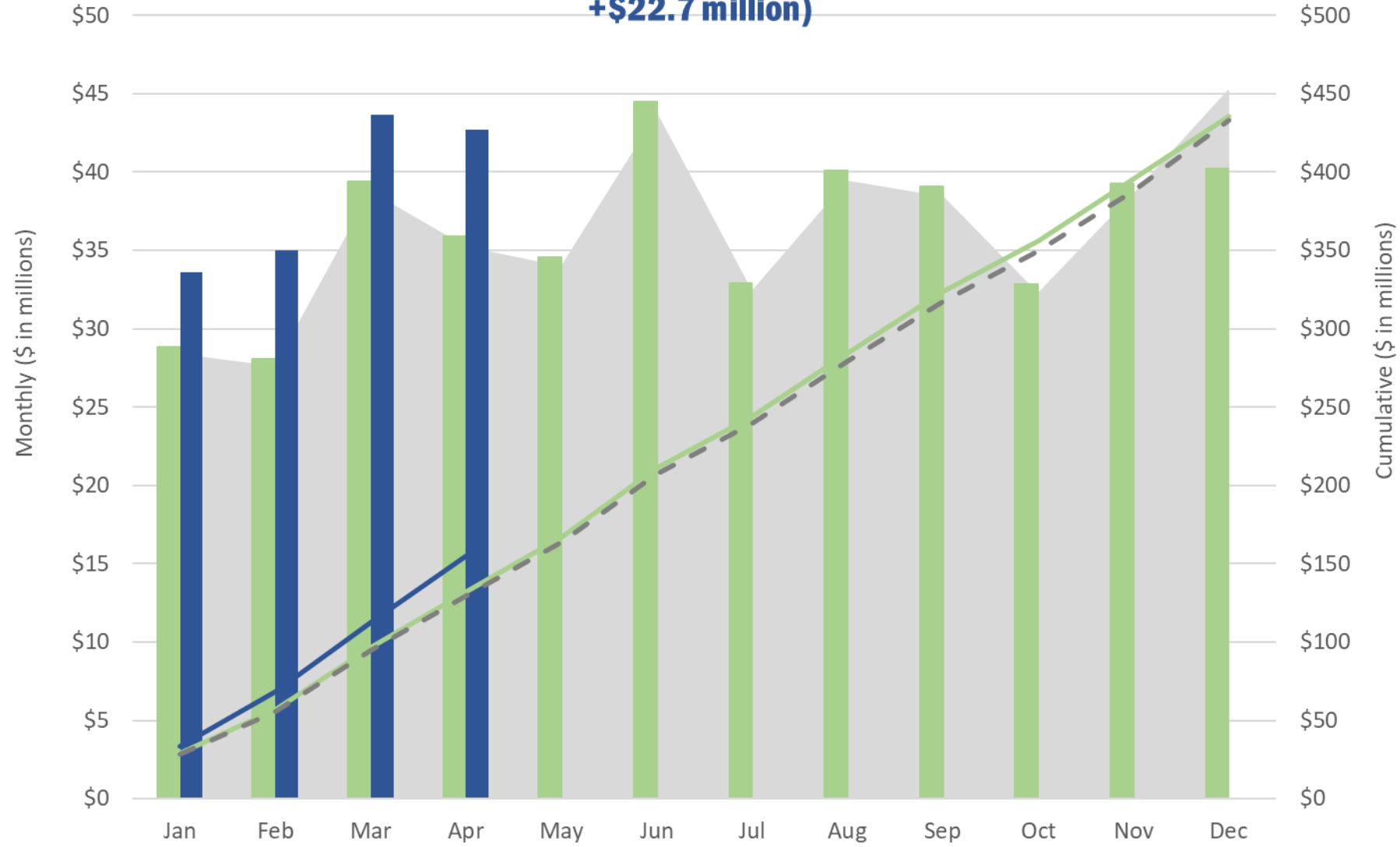

Sales Tax Collections (Percentage Growth for 12 months ended April 30, 2022)

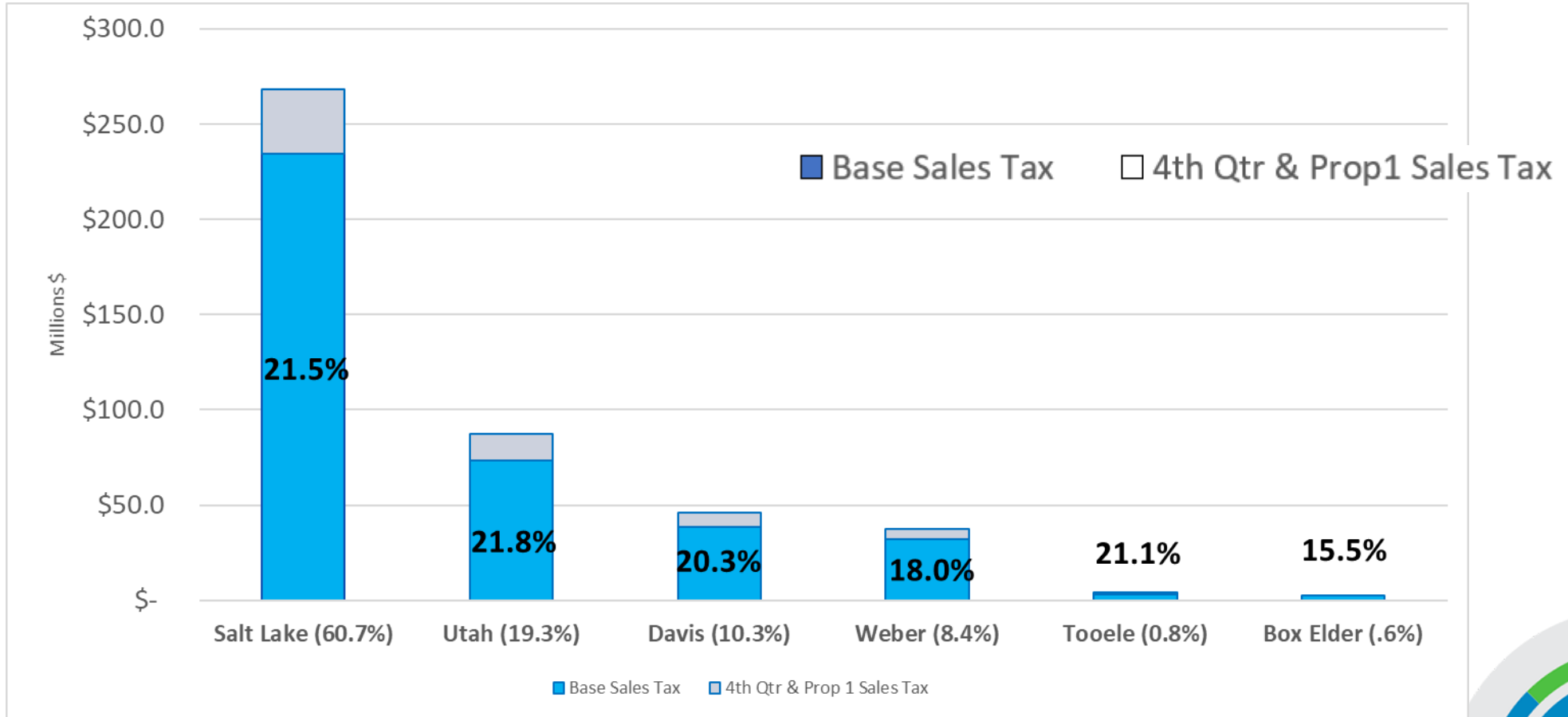

- % growth in base sales tax revenues over prior year
- (includes impact of Prop1 and 4th quarter rate changes in 2019).

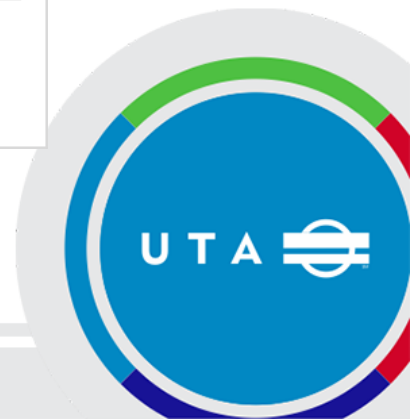

2022 Passenger Revenues

May Variance = \$0.182 million

UTAH TRANSIT AUTHORITY

- 2021 Actual
- Mo Budget
- Mo Actuals
- Cum Budget
- Cum Actual
- Cum 2021

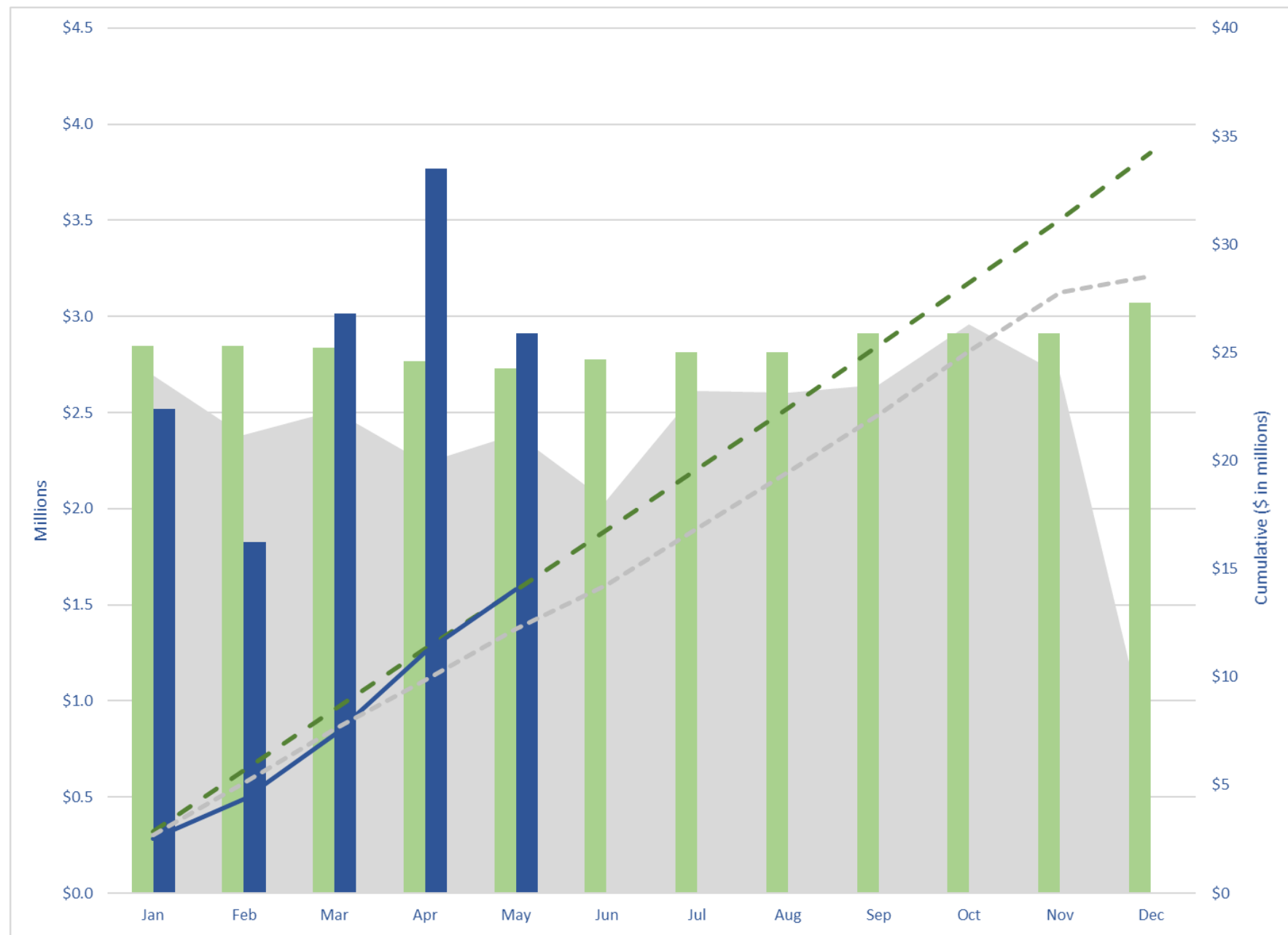

May 2022

MONTHLY RESULTS					FISCAL YEAR 2022 Dollars in Millions	YEAR-TO-DATE RESULTS				
Prior Year	Current Year					Prior Year	Current Year			
Actual	Actual	Budget	Variance			Actual	Actual	Budget	Variance	
					Revenue					
\$ 38.1	\$ 38.8	\$ 34.6	\$ 4.2	12.2%	Sales Tax <i>(Apr accrual)</i>	\$ 150.6	182.7	\$ 166.8	\$ 15.9	9.5%
2.4	2.9	2.7	0.2	6.6%	Fares	12.2	14.0	14.0	0.0	0.1%
77.8	35.7	19.7	16.1	81.8%	Federal	135.6	161.1	102.4	58.7	57.4%
1.2	1.4	1.7	(0.3)	-19.3%	Other *	3.9	6.5	6.9	(0.4)	-5.9%
\$ 119.4	\$ 78.8	\$ 58.7	\$ 20.2	34.4%	TOTAL REVENUE	\$ 302.4	\$ 364.3	\$ 290.1	\$ 74.2	25.6%
					Expense					
\$ 11.6	\$ 13.7	\$ 14.3	\$ 0.6	4.3%	Salary/Wages	\$ 63.4	\$ 69.1	\$ 71.3	\$ 2.2	3.1%
6.2	6.6	7.0	0.4	5.4%	Fringe Benefits	31.0	33.5	35.3	1.8	5.1%
1.7	3.2	2.4	(0.7)	-29.7%	Services	9.1	10.9	13.4	2.5	19.0%
2.0	1.4	1.9	0.5	28.8%	Parts	8.2	7.1	9.5	2.4	25.4%
1.4	2.2	2.3	0.1	2.8%	Fuel	8.4	10.2	11.3	1.0	9.2%
0.2	0.1	0.5	0.3	74.3%	Utilities	2.6	2.5	2.6	0.1	2.7%
0.6	0.9	1.6	0.7	43.0%	Other	3.7	4.5	8.1	3.6	44.3%
(0.7)	(0.6)	(0.9)	0.2	-27.5%	Capitalized Cost	(3.7)	(3.0)	(4.5)	1.5	-32.9%
\$ 23.0	\$ 27.4	\$ 29.1	\$ 1.7	5.7%	TOTAL EXPENSE	\$ 122.7	\$ 134.8	\$ 147.0	\$ 12.2	8.3%
\$ 7.6	\$ 6.8	\$ 6.8	\$ 0.1	0.9%	Debt Service	\$ 38.3	\$ 34.1	\$ 34.2	\$ 0.0	0.1%
\$ 88.7	\$ 44.6	\$ 22.7	\$ 21.9	96.2%	Contrib. Capital/Reserves	\$ 141.4	\$ 195.4	\$ 108.9	\$ 86.5	79.4%

Favorable/(Unfavorable)

* Does not include loss on Sale of Assets: 2021 \$7.5M & 2022 \$3.5M.

Favorable/(Unfavorable)

Questions?



Capital



Program Summary

2022 Capital Spending Program Summary- Total Spent \$57.2M of Planned \$56.6M, 1%

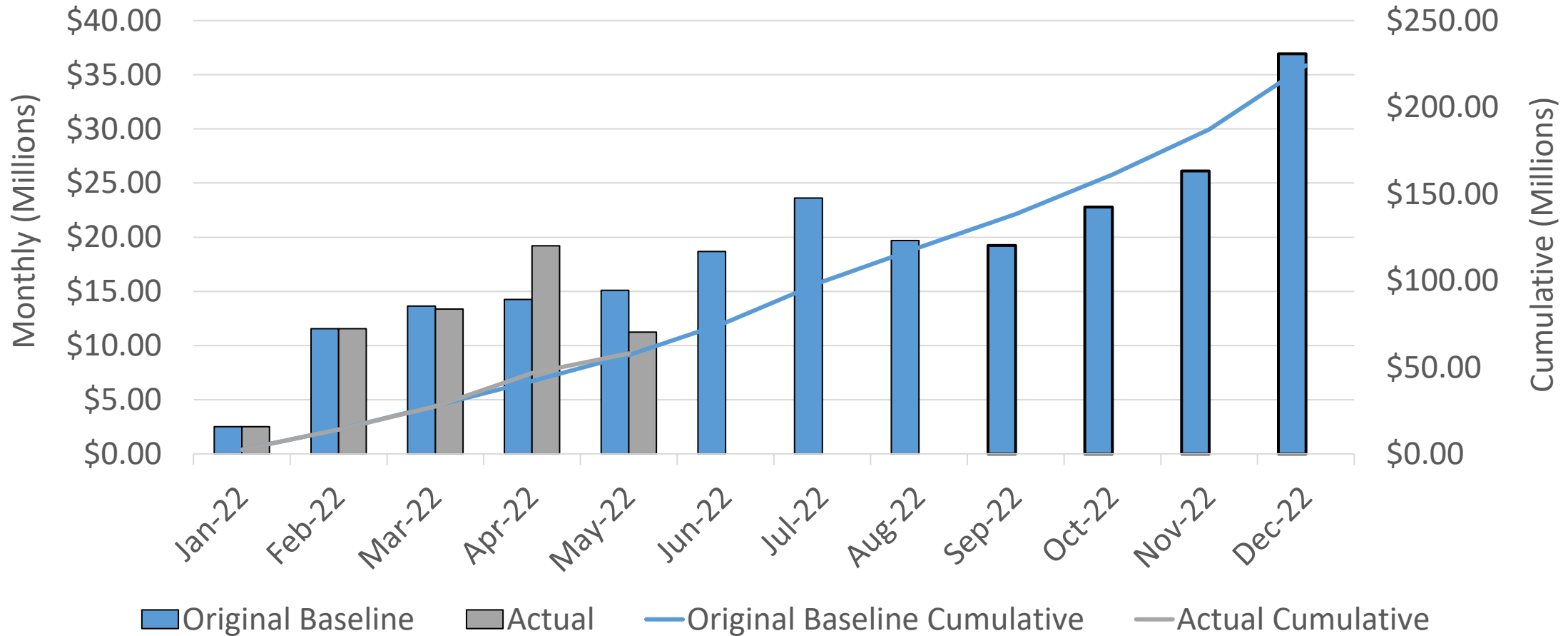

Capital Construction

Capital Construction- Total Spent \$23.9M of Planned \$28.97M, -18%

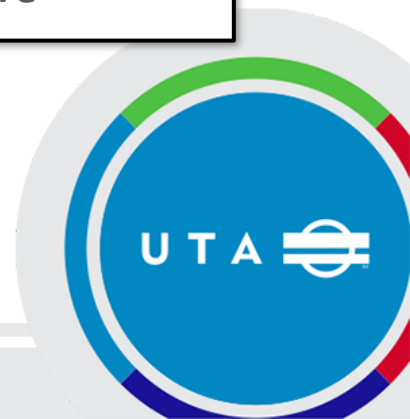
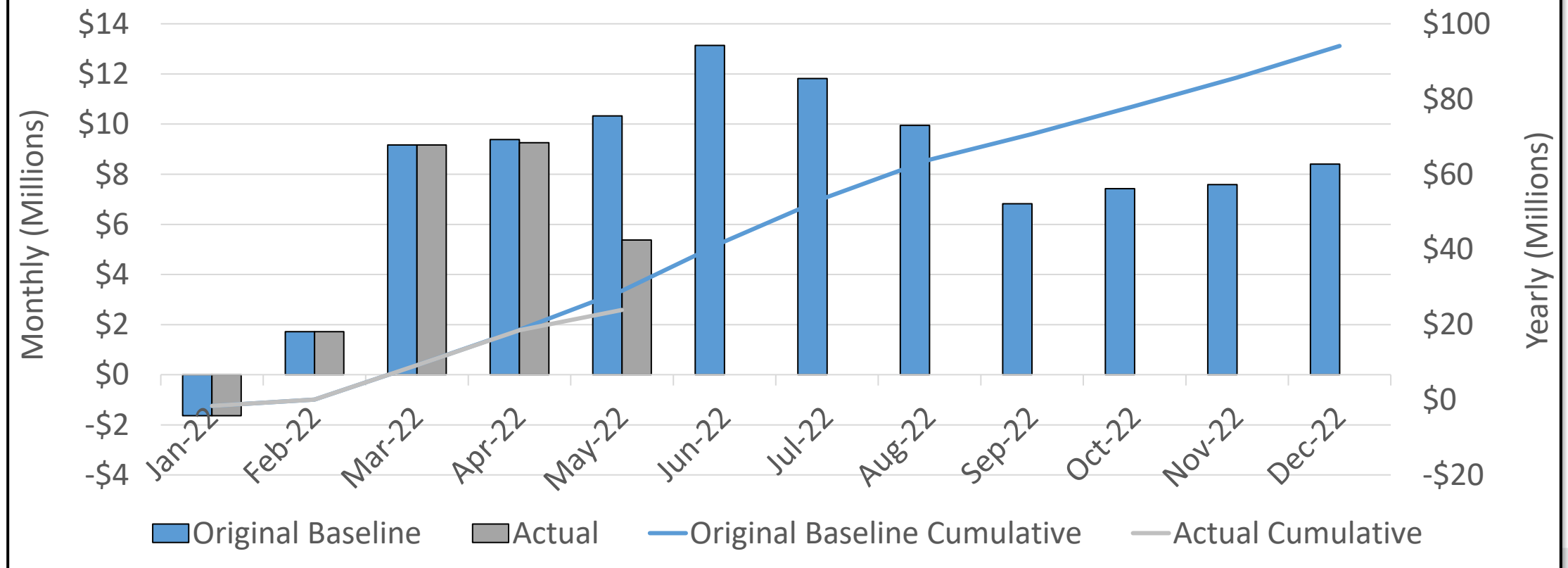

Capital Development

Capital Development- Total Spent \$5.98 M of Planned \$6.1M, -1%

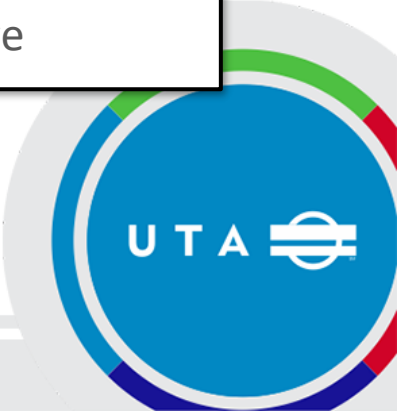
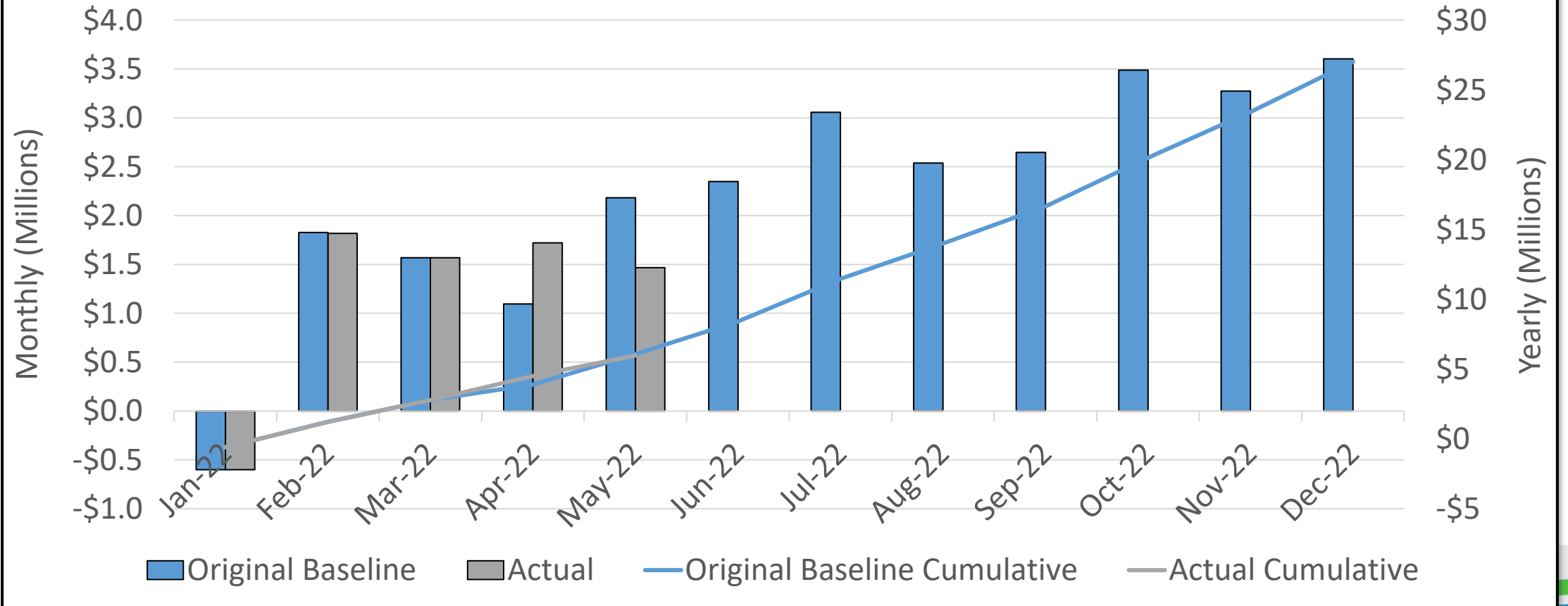

Infrastructure SGR Projects

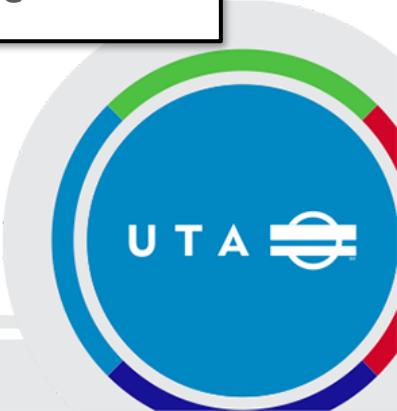
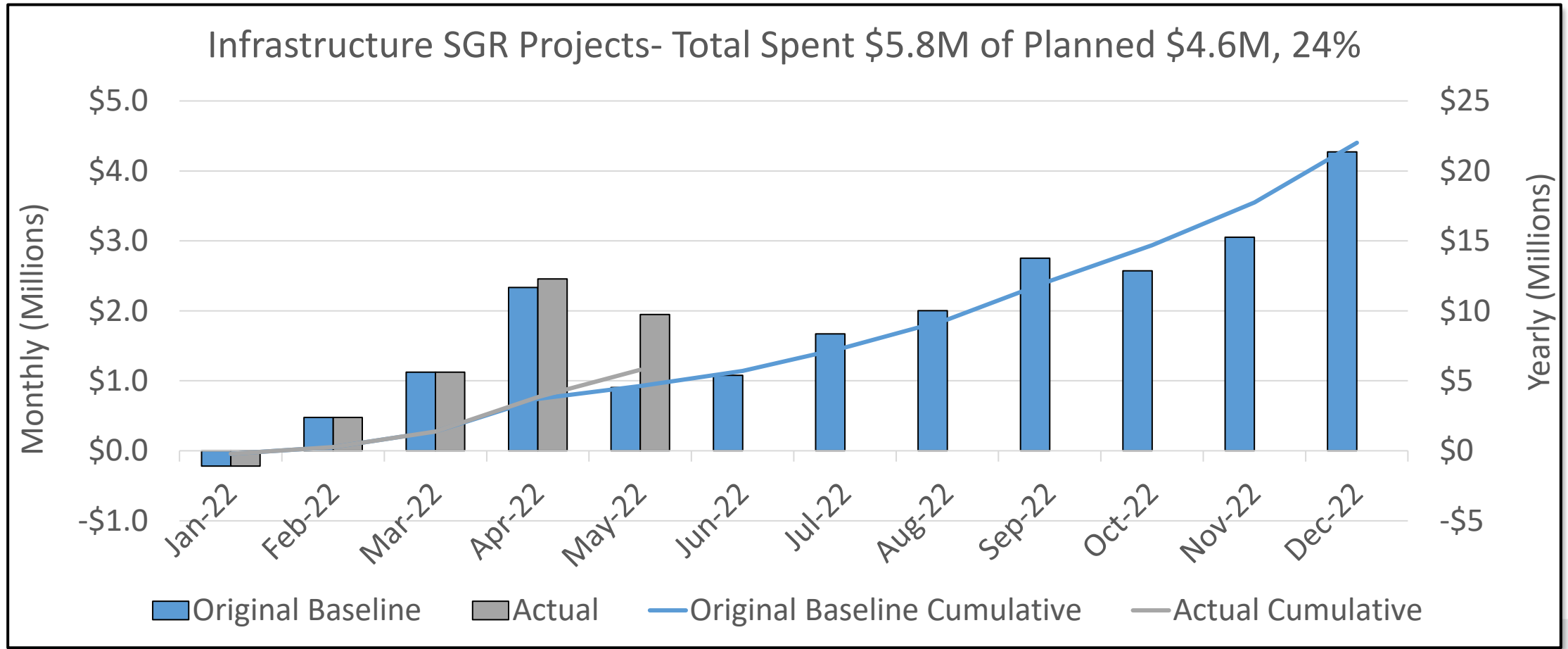

Revenue/Service Vehicles

Revenue/Service Vehicles- Total Spent \$18.7M of Planned \$15.1, 24%

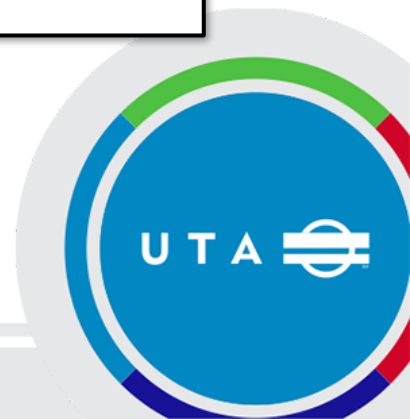
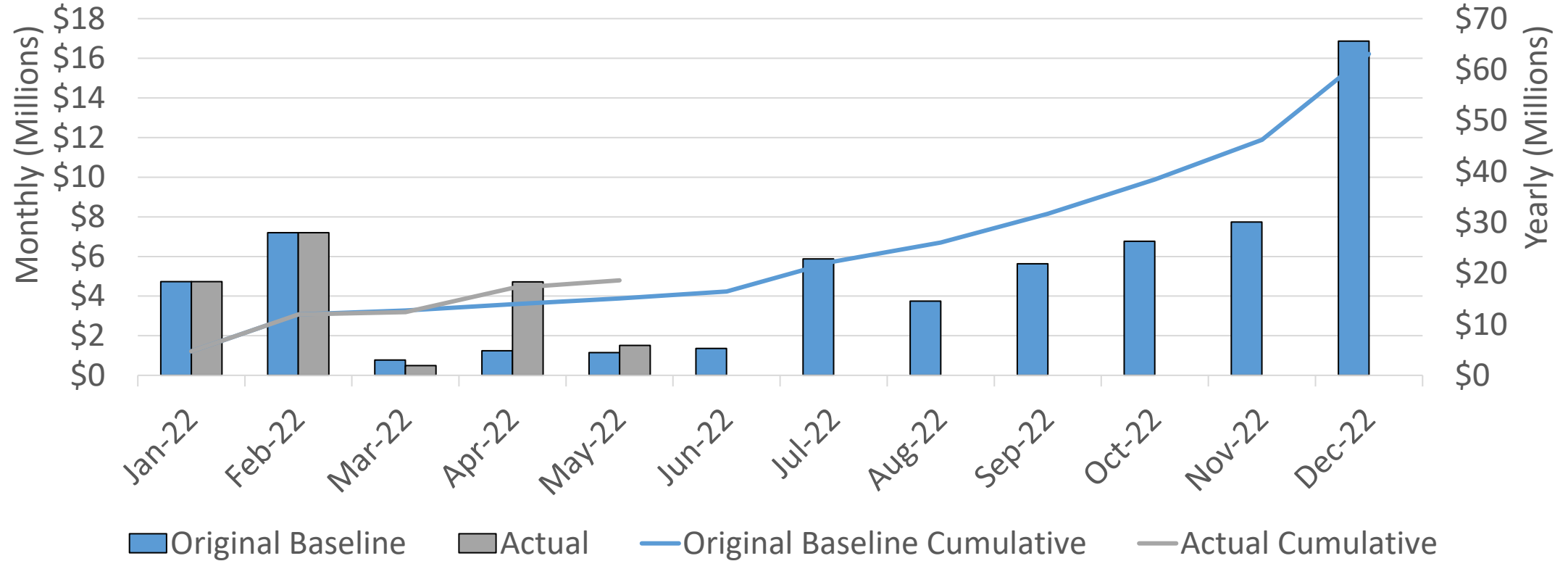

Facilities- SGR

Facilities- SGR- Total Spent \$700,000 spent of planned \$638,000, 10%

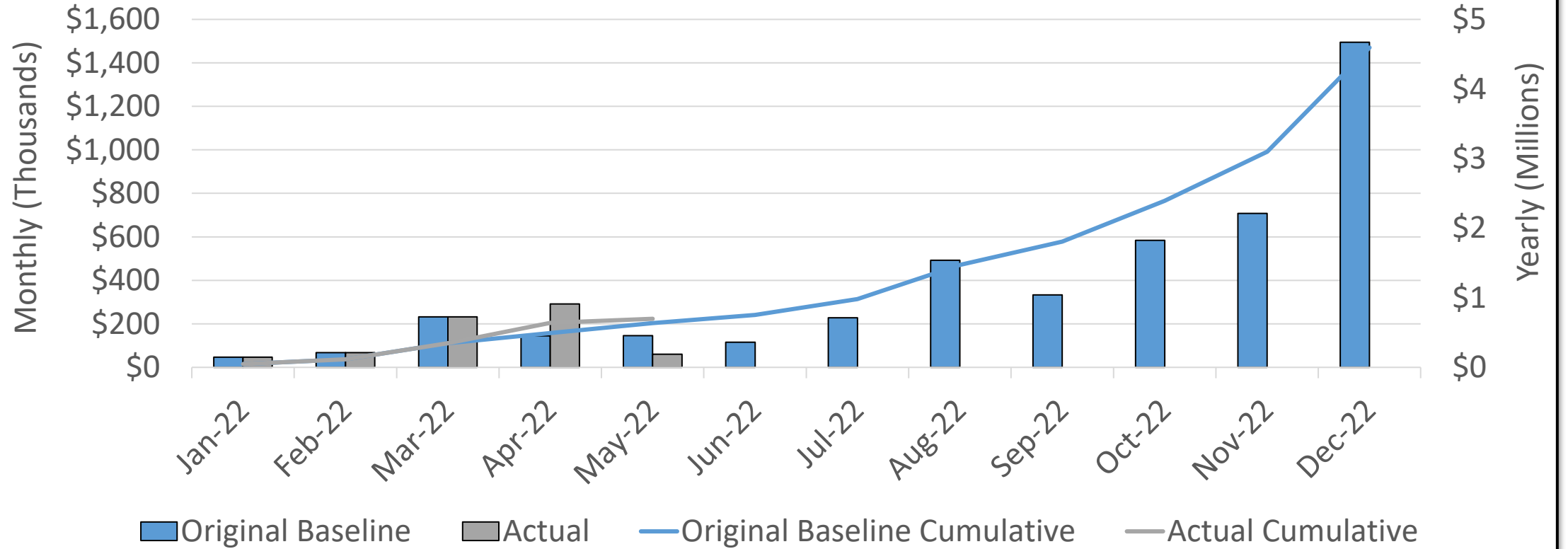

Safety and Security

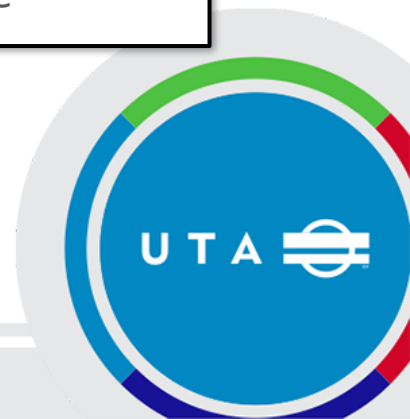
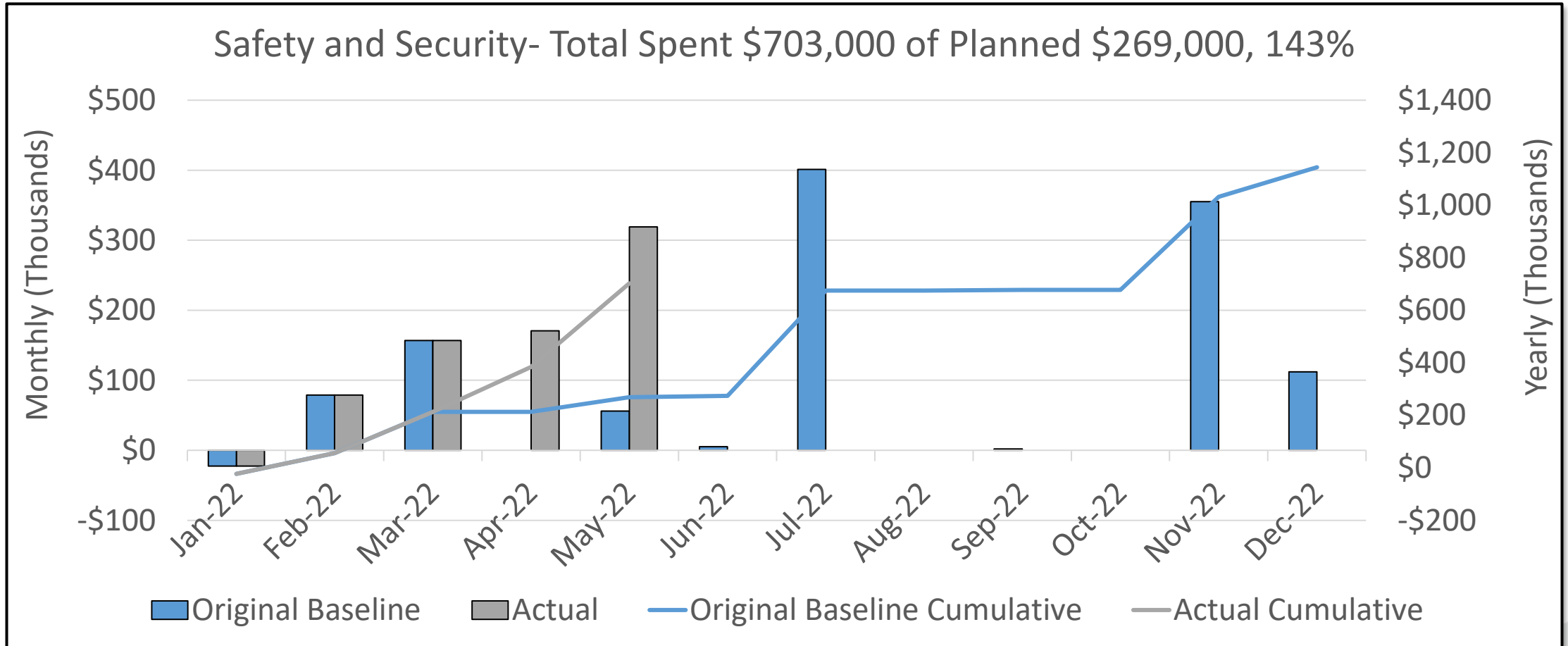

Information Technology Projects

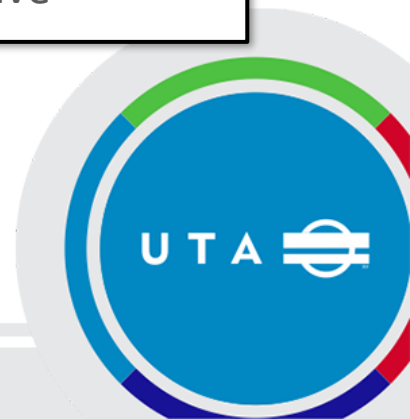
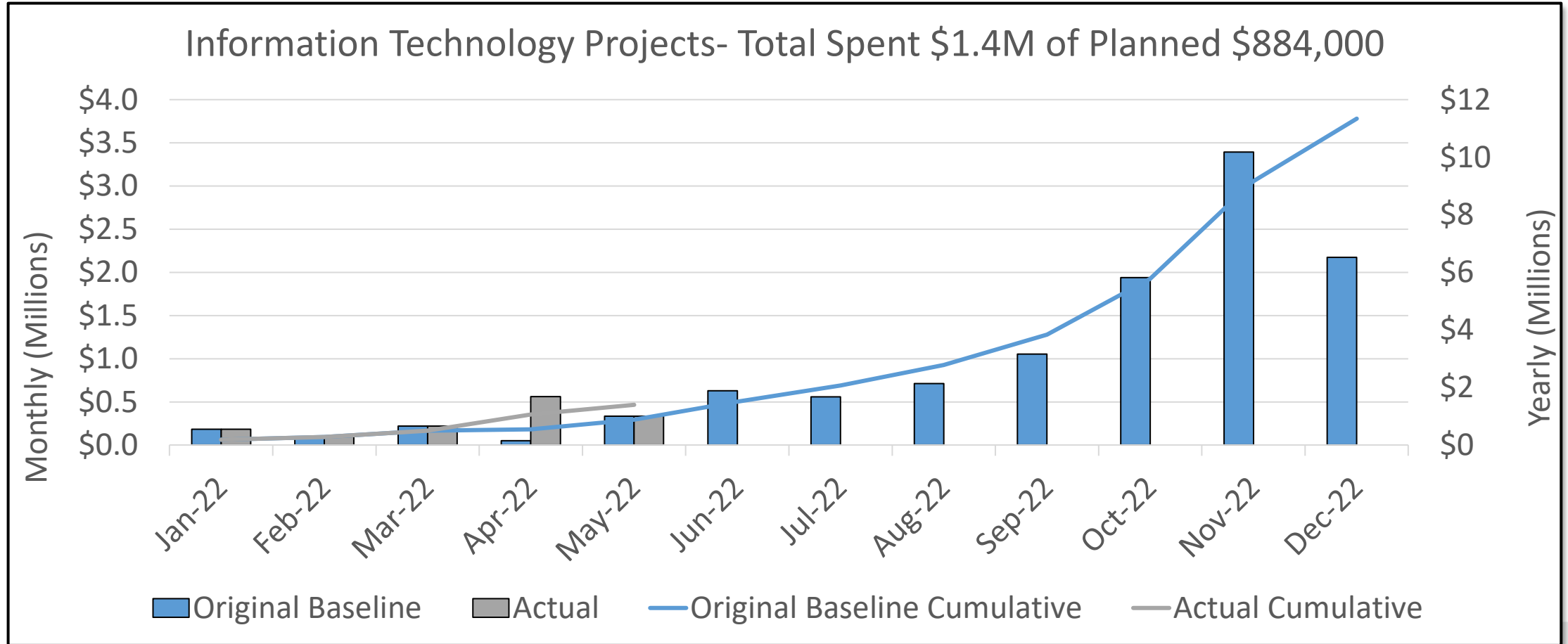

MSP102- Depot District

- Interior work is progressing
 - Concrete sealant occurring
 - Plumbing fixtures being installed in one area
- Outside utility work occurring

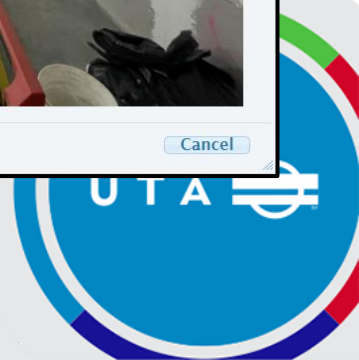
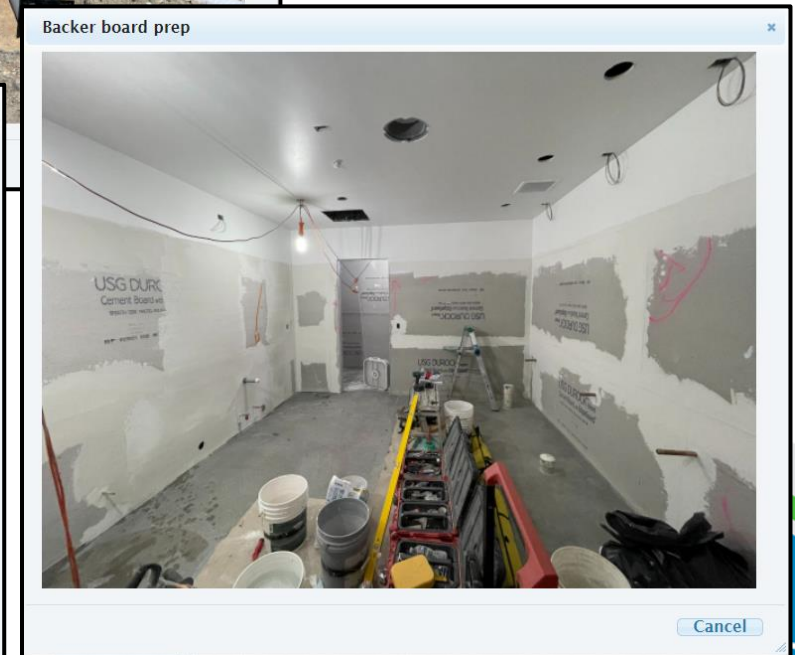
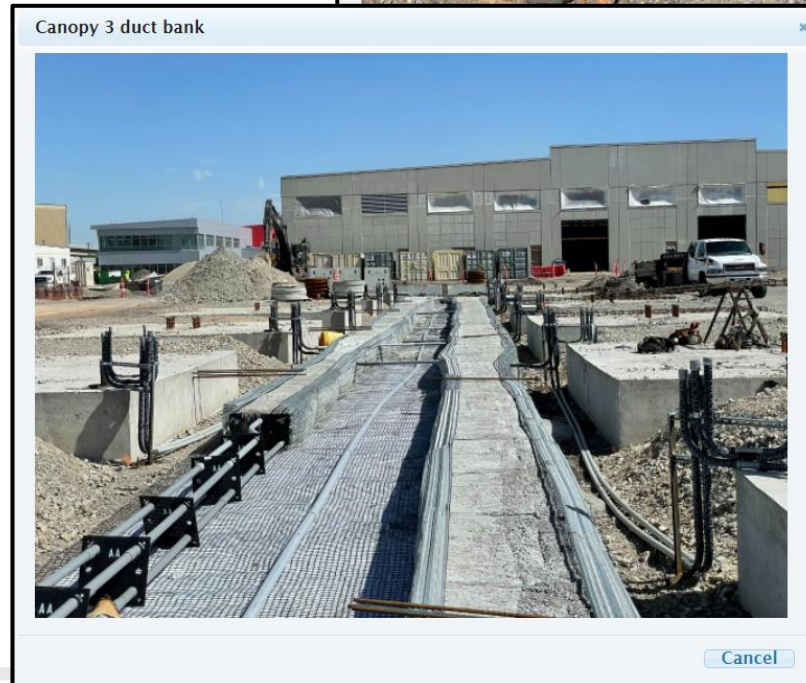

Questions?



Resolutions



R2022-07-01
Resolution Adopting Revised
Ordinances Governing Authority
Services and Property



UTA Public Ordinance Update

- UTA Ordinances: Pursuant to Utah Code Ann. §§ 17B-1-301 and 17B-2a-808; A board of trustees of a large public transit district may:
 - Establish Ordinances necessary for:
 - (A) the governance and management of the affairs of the district;
 - (B) the execution of district powers; and
 - (C) carrying into effect the provisions of this part;
- Goals of the update
 - Increase compliance, clarify and make consistent
 - Update to align with new technologies and current practices
 - Review internal processes and procedures
- Cross-functional team review



UTA Fare Payment Ordinance Overview

The draft ordinance includes six sections:

1. Definitions
2. Fare Payment
3. Fare Enforcement
4. Fines
5. Protests
6. Right to Appeal



Criminal Ordinance Overview

The draft ordinance includes 10 sections:

1. Definitions
2. Authority
3. Rules of Construction
4. Adoption of Utah Codes
5. Classification of Offenses
6. Vehicles
7. Use of Transit Facilities
8. Conduct While Using Transit Facilities
9. Property
10. Enforcement



Trespassing Ordinance Overview

The draft ordinance includes 10 sections:

1. Definitions
2. Authority
3. Trespass for Minor Offense (up to 30 days)
4. Trespass for Serious Offense (up to one year)
5. Permanent Trespass
6. Other Remedies
7. Records
8. Protests
9. Right to Appeal



Public Engagement

Approaches:

- Public notice
- CAC & CAT notification
- Social media
- Virtual public meeting & live stream

Feedback:

- Minimal feedback was received
- Suggestion to improve accessibility of processes
- Suggestion to reconsider animal rules
- Customer service & interactions comment



Questions?



Recommended Action

(by roll call)

Motion to approve R2022-07-01
Resolution Adopting Revised Ordinances Governing Authority Services and Property



R2022-07-02

**Resolution Authorizing Execution of
Amendment 1 to Addendum 3, and
Addendum 6 to the Salt Lake City
Transit Master Plan Interlocal
Agreement for 2020-2023 Frequent
Transit Network Routes**



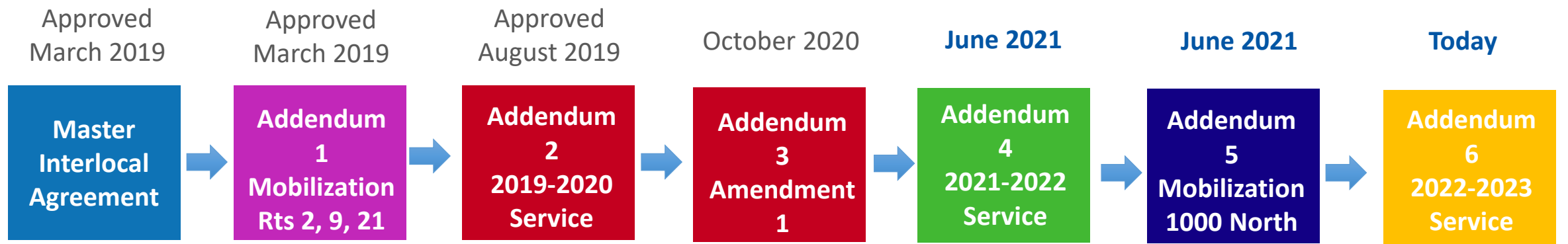

Established framework for partnership and methodology for calculating costs and annual reconciliation

Authorized the exchange of funds to hire and train operators, procure buses

Authorized the exchange of funds to deliver the sponsored service for the period of one year

1) Authorizes a discount to SLC in proportion to reduction of service due to COVID-19,
2) Annual Fuel and mileage "true-up" per the ILA

Authorizes the exchange of funds to extend the sponsored service for another year

Authorizes the exchange of funds to hire and train new operators, procure buses

Authorizes the exchange of funds to extend the sponsored service for another year, adds 1000 N





Addendum 3 – 2020-2021 Service

Miles

- 19,802 miles now meet UTA baseline service standards
- 491,862 miles sponsored by City

Fuel

- \$2.00/gallon
- 4.8 gallons/mile

Financial

- Based on 2018 NTD Costs/mile
- 2.2% inflation rate
- \$41,088 actual vehicle lease rate

Total Amount:

\$4,290,092

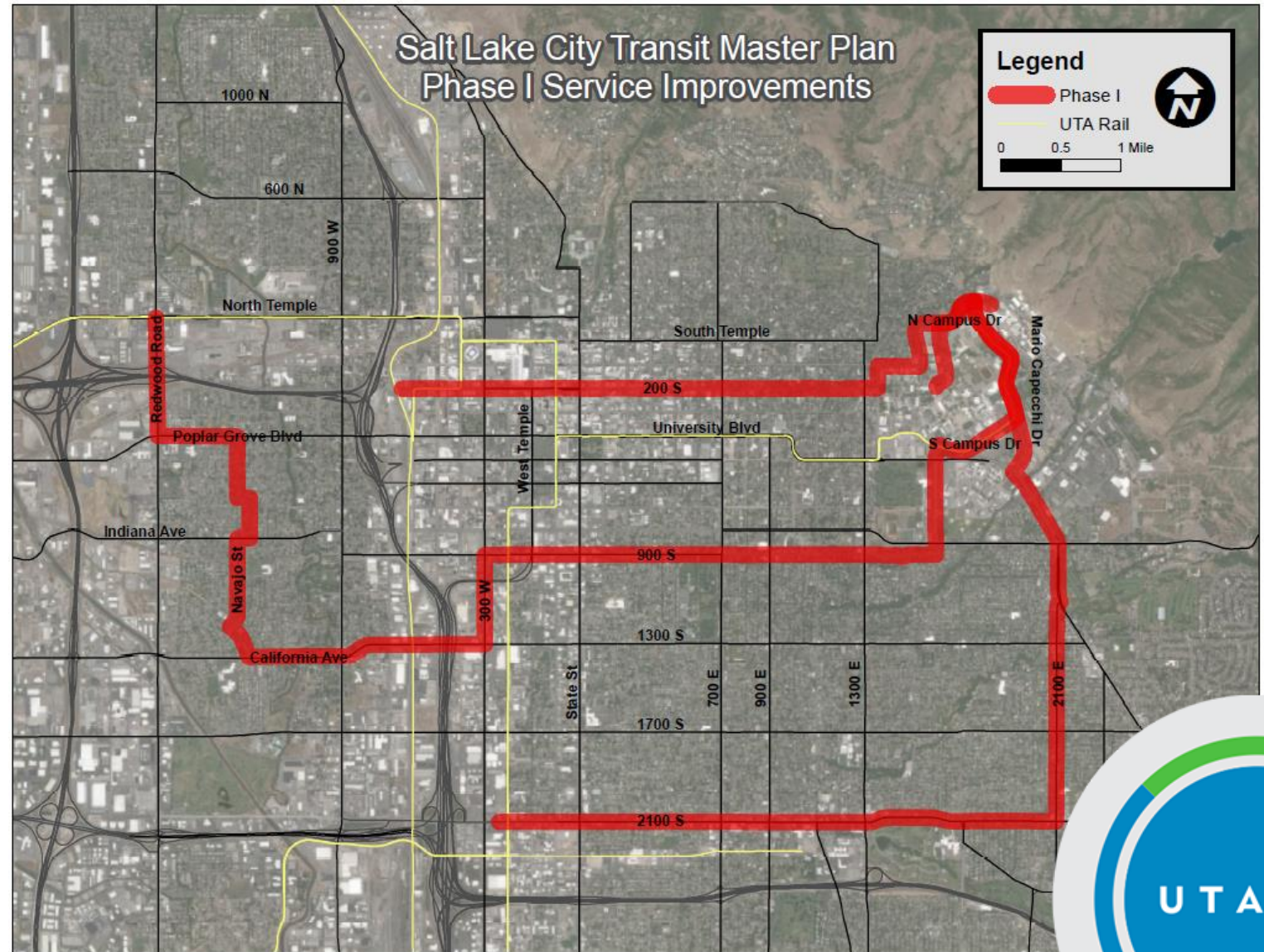



Amendment No. 1 to Addendum No. 3

Addresses changes to agreed upon service levels due to the COVID-19 Pandemic

- Descriptions of FTN Routes remain unchanged
- The frequency of the baseline services set forth in Addendum No 3. was decreased due to diminished demand caused by COVID-19.

SLC Funding Reduction

- SLC provided with an annualized service discount of \$36,364.
- The discount shall be made as a one-time payment and reflected in the July 2022 invoice.

Any other provision of Addendum No. 3 not affected by these changes remain in full force and effect.





Addendum 4 – 2021-2022 Service

Miles & Service

- 493,061 miles City Sponsored Service

Fuel

- \$2.25/gallon
- 5 gallons/mile

Financial

- 2.2% inflation rate
- Based on 2019 NTD costs/mile
- \$49,306 actual vehicle lease rate
- \$371,305 Paratransit

Total Amount (Addendum 4):

\$4,475,416

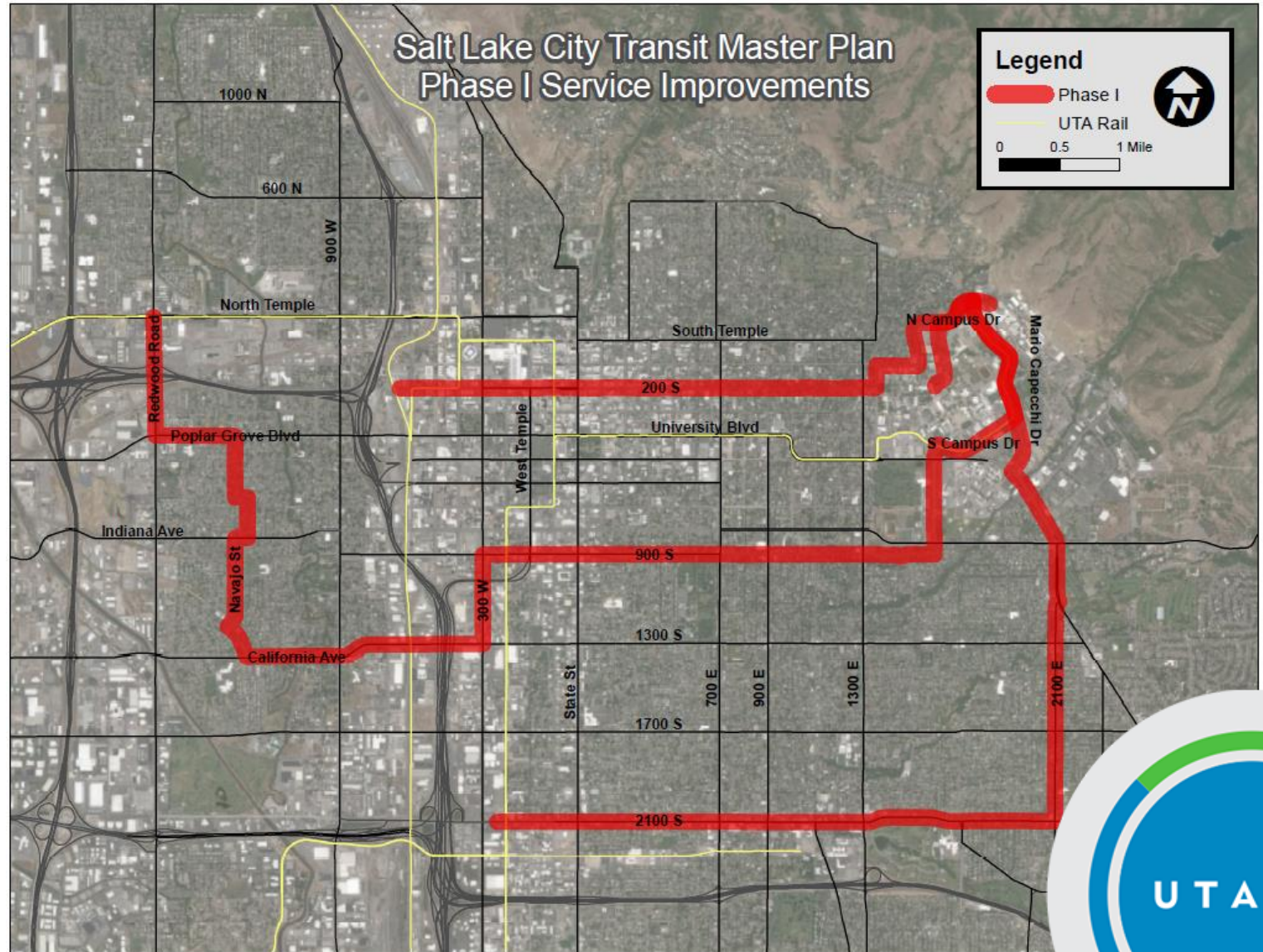



Addendum 5 – 1000 N Mobilization:

- 15 new operators (hire & train)
- 4 new buses
- 2 mechanics
- 1 supervisor
- 1 TCC dispatch operator

Total Amount:
\$949,322

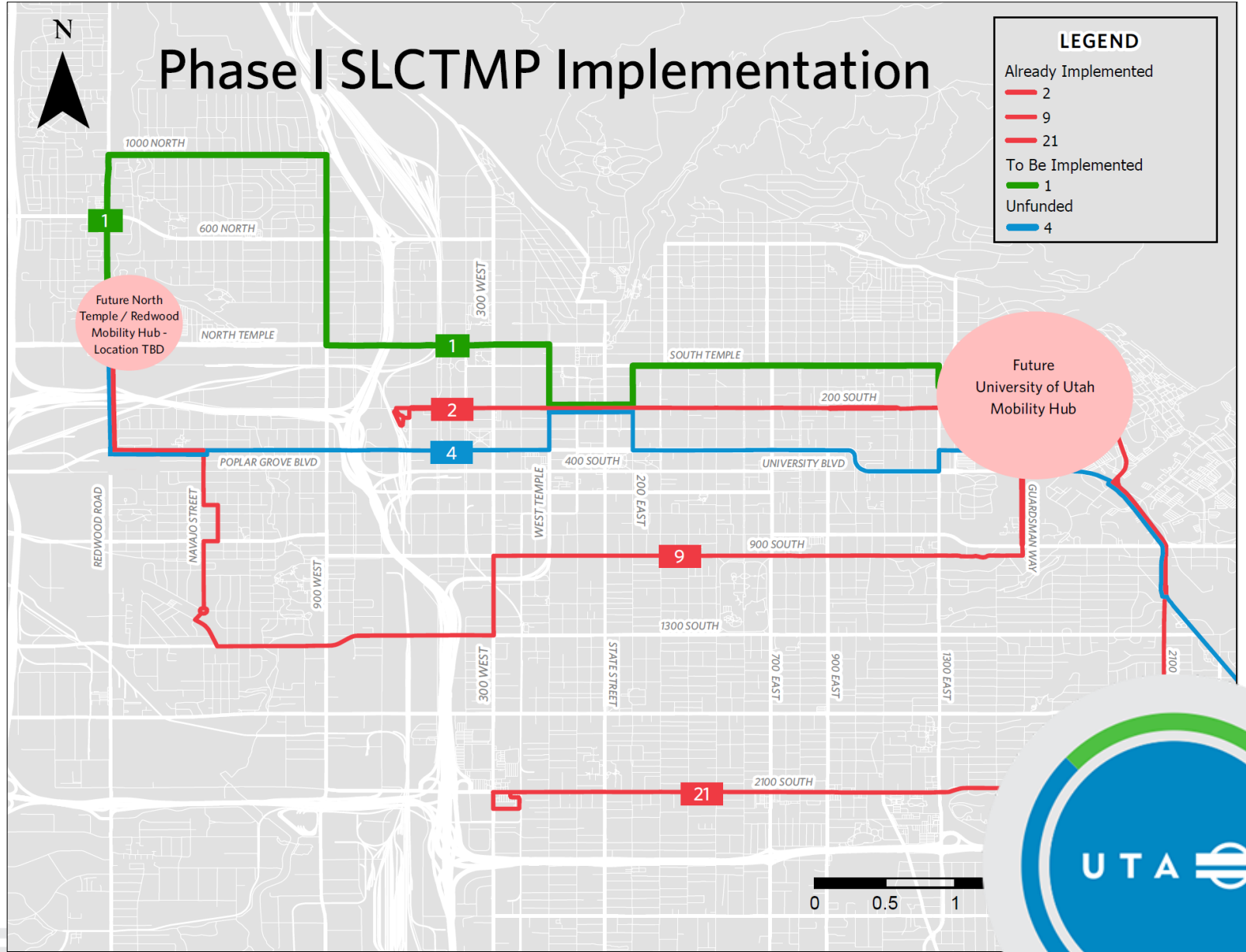



Addendum 6 – 2022-2023 Service

Miles & Service

- 617,498 miles City Sponsored Service

Fuel

- \$2.75/gallon
- 4.85 gallons/mile

Financial

- 2.2% inflation rate
- Based on 2020 NTD costs/mile
- \$49,306 actual vehicle lease rate for first 10 vehicles
- \$43,845 actual vehicle lease rate for 4 new vehicles
- \$409,497 Paratransit

Total Amount (Addendum 6):

\$6,547,726

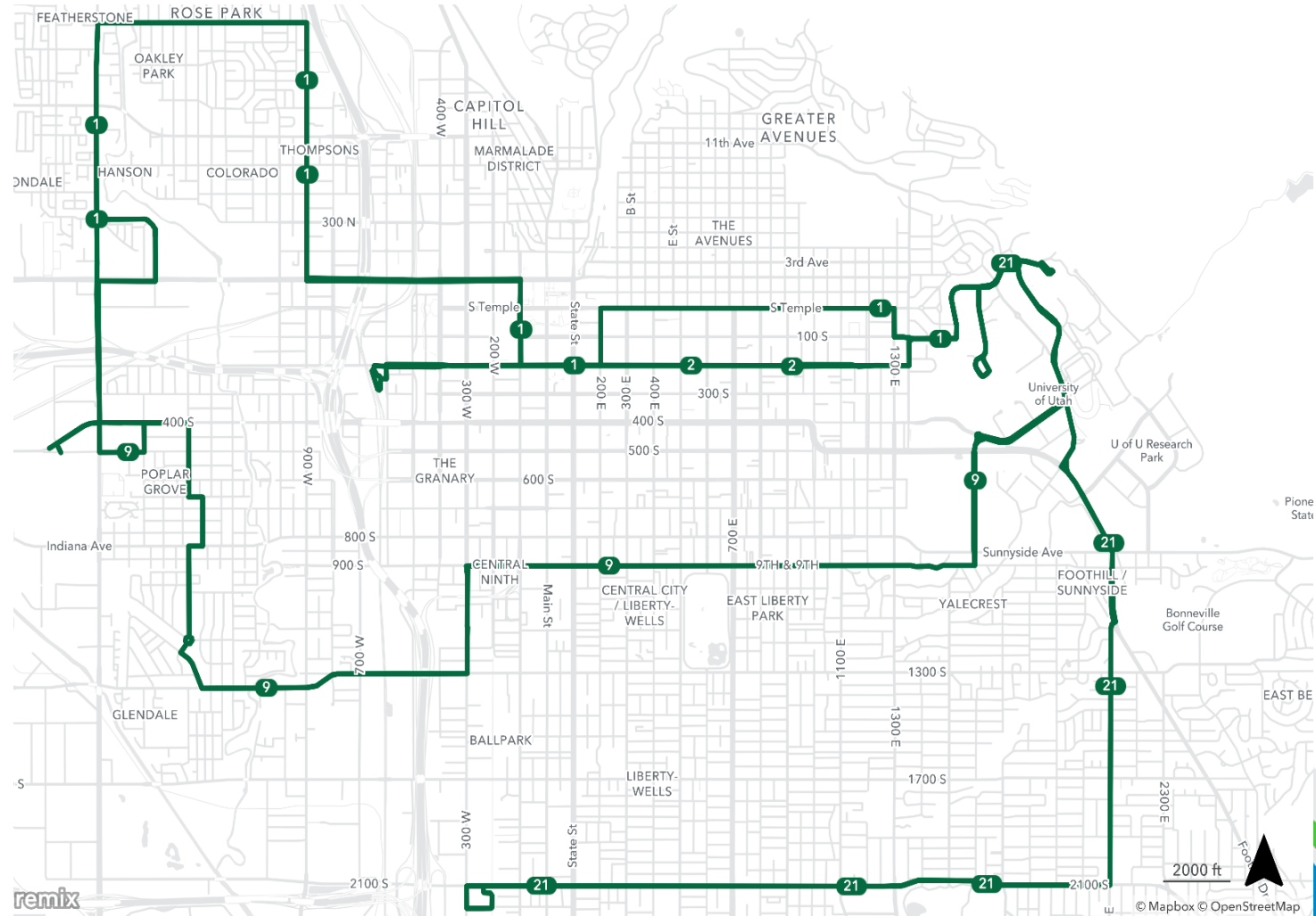



August 2022 Service and beyond

Additional Service Includes:

- Salt Lake Trips To Transit – Microtransit in Glendale/RosePark Area
- 400 South

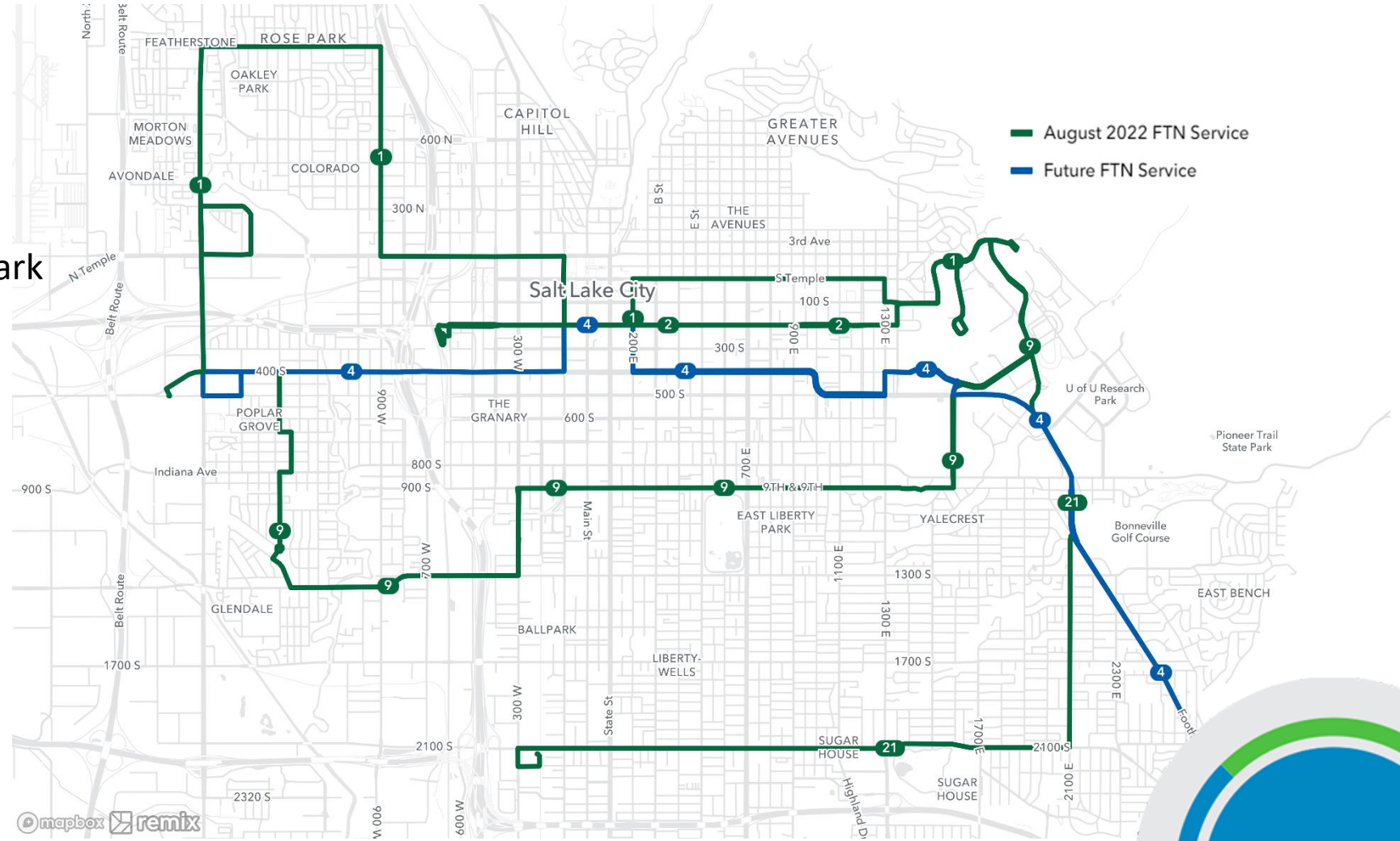

Recommended Action

(by roll call)

Motion to approve R2022-07-02

Resolution Authorizing Execution of Amendment 1 to Addendum 3, and Addendum 6 to the Salt Lake City Transit Master Plan Interlocal Agreement for 2020-2023 Frequent Transit Network Routes



R2022-07-03

**Resolution Authorizing an Amended and
Restated Agreement with the Utah
Department of Transportation for the
Mountain View Corridor Project
Implementation for Phase I Transit**



Project Overview

- By 2050 the population is projected to double, this growth is occurring on the west side of Salt Lake County
- The Westside Express will be delivered by 20 new electric busses and will offer a one-seat transit ride for residents that previously would have had 1 to 3 transfers
- The 29-mile route will include connection to:
 - 5600 West to Salt Lake City International Airport, downtown Salt Lake City, and other regional job centers
 - UTA's TRAX Lightrail system at the Old Bingham Highway Red Line Station at the route's southern end
 - Five Green Line TRAX stations to the north and west
 - Enhanced stops with shelters, benches, lighting, and real-time bus arrival displays along with six park and ride lots



Project Overview

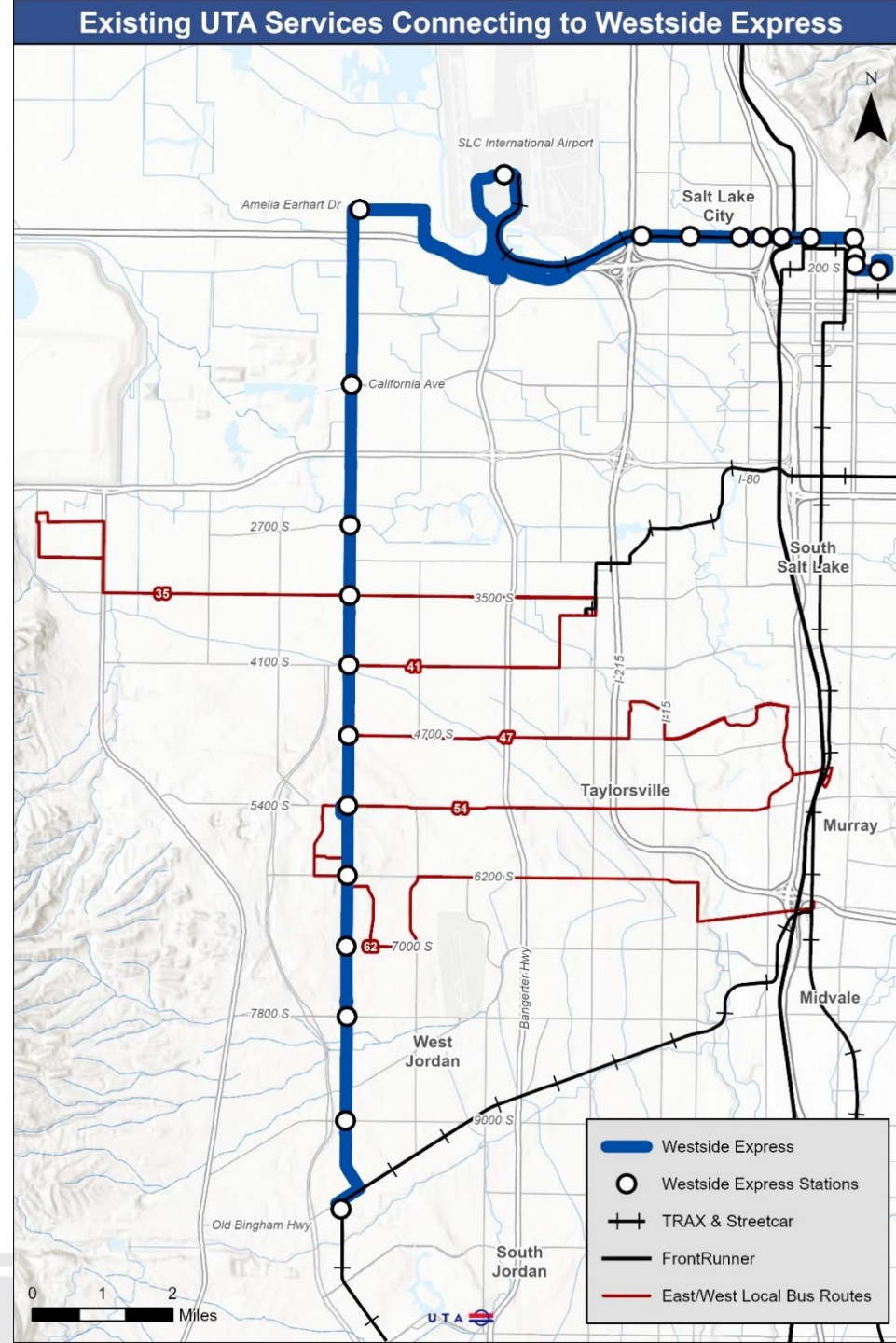

Westside Express Connector Map

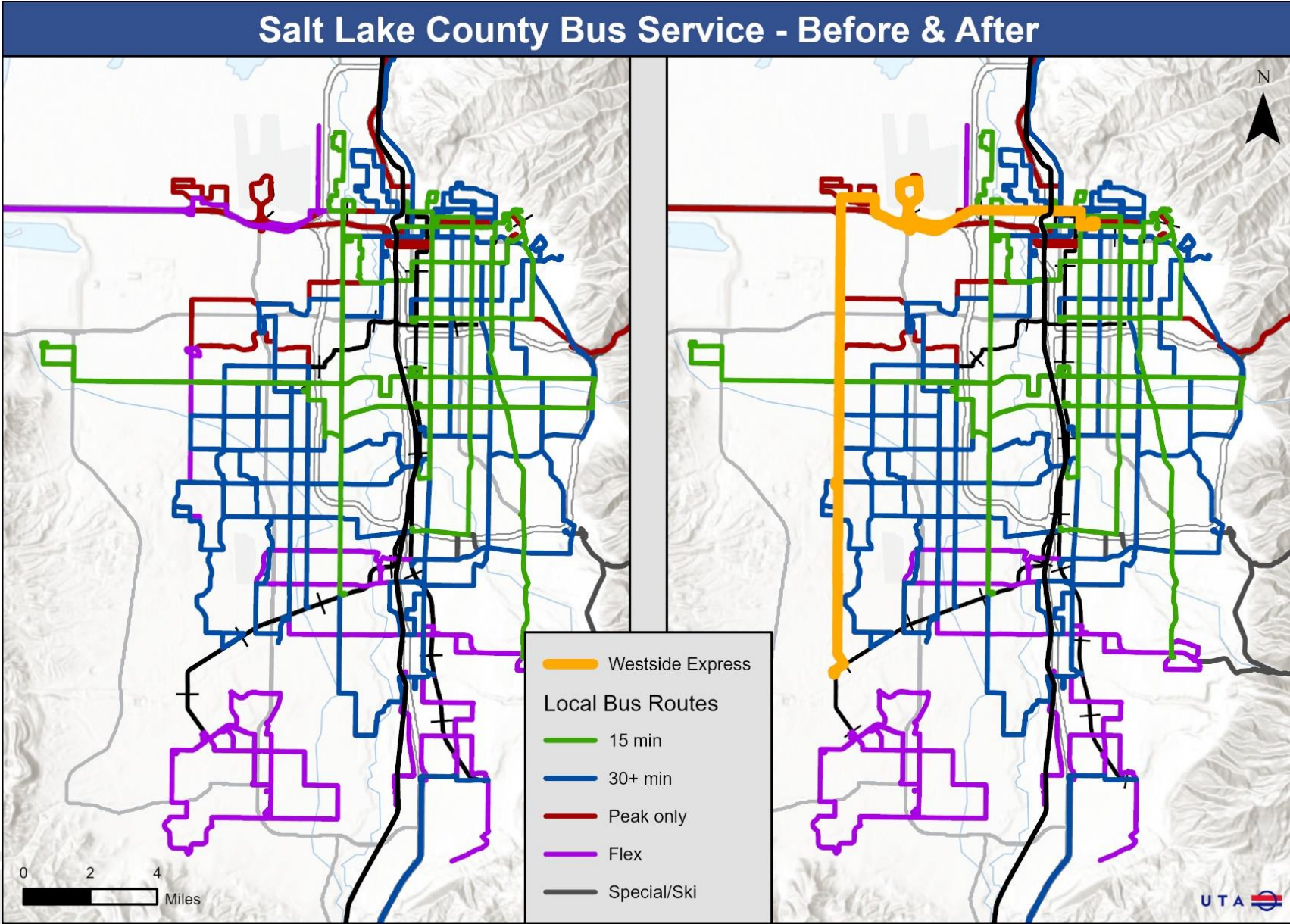

Project Background



- The original transit component was arranged in the 2008 Record of Decision (ROD) as a mitigation for the freeway component of Mountain View Corridor (MVC) congestion relief project
- Originally, the transit mitigation was a five-mile Bus Rapid Transit (BRT) line along 5600 West, with potential future conversion to Light-Rail Transit (LRT)
- The impacts of the 2008 recession dramatically reduced UTA's expected revenues and consequentially was unable to implement the BRT service
- Further market evaluation showed the proposed project would have limited ridership with a high cost
- Due to a shared desire UDOT and UTA agreed to reevaluate in 2019 and refined the transit component to an express bus route of 29 miles
- The Express bus concept produced much higher ridership at a lower cost



Discussion

- UDOT and UTA developed a refined Selected Alternative for Phase 1 transit implementation which addresses the MVC's purpose. Phase 2 and 3 transit and project implementation will be addressed after the Phase 1 elements are fully implemented; they were not part of the EIS Re-evaluation.
- Phase 1 transit is now an Express Bus service along the existing 5600 West and North Temple roadway travel lanes from the Old Bingham Highway TRAX station to downtown Salt Lake City. This change will allow transit to be implemented more cost-effectively.



Recommendation

- Approve the Amended and Restated Mountain View Corridor Agreement with the Utah Department of Transportation



Next Steps

- Update UDOT MVC Agreement
- Complete fundraising: Raise Grant is pending



Questions



Recommended Action

(by roll call)

Motion to approve R2022-07-03

Resolution Authorizing an Amended and Restated Agreement with the Utah Department of Transportation for the Mountain View Corridor Project Implementation for Phase I Transit



Contracts, Disbursements, and Grants



Contract: Bus Stop Improvements for Salt Lake County 2022 (Landmark Companies)

Recommended Action (by acclamation)

Motion to approve the contract with Landmark Companies for 2022 bus stop improvements in Salt Lake County, as presented



Change Order: SD100/SD160/S70 LRV Seating Replacement Contract Modification 1 (United Safety and Survivability Corporation)

Recommended Action (by acclamation)

Motion to approve Modification 1 to the contract with United Safety and Survivability Corporation for the SD100/SD160/S70 LRV seating replacement, as presented



UTA LRV Seating Replacement

UTAH TRANSIT AUTHORITY



Existing Back-to-back Seating

Old/existing back to back seating

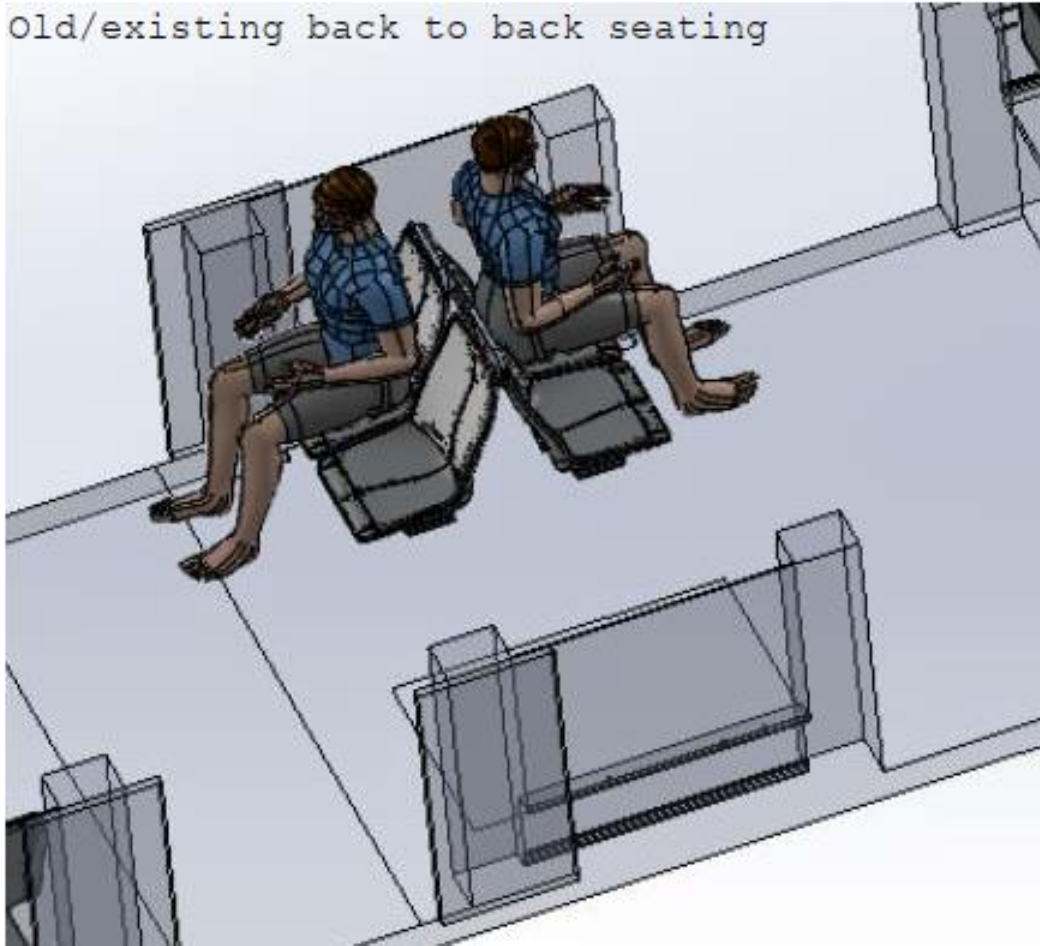

- Current low floor back-to-back seating causes additional passenger leg/foot protrusion into the doorway by around 2"
- This reduces the usable door width from 44.9" to 42.9"

New Longitudinal Flip Seating Design

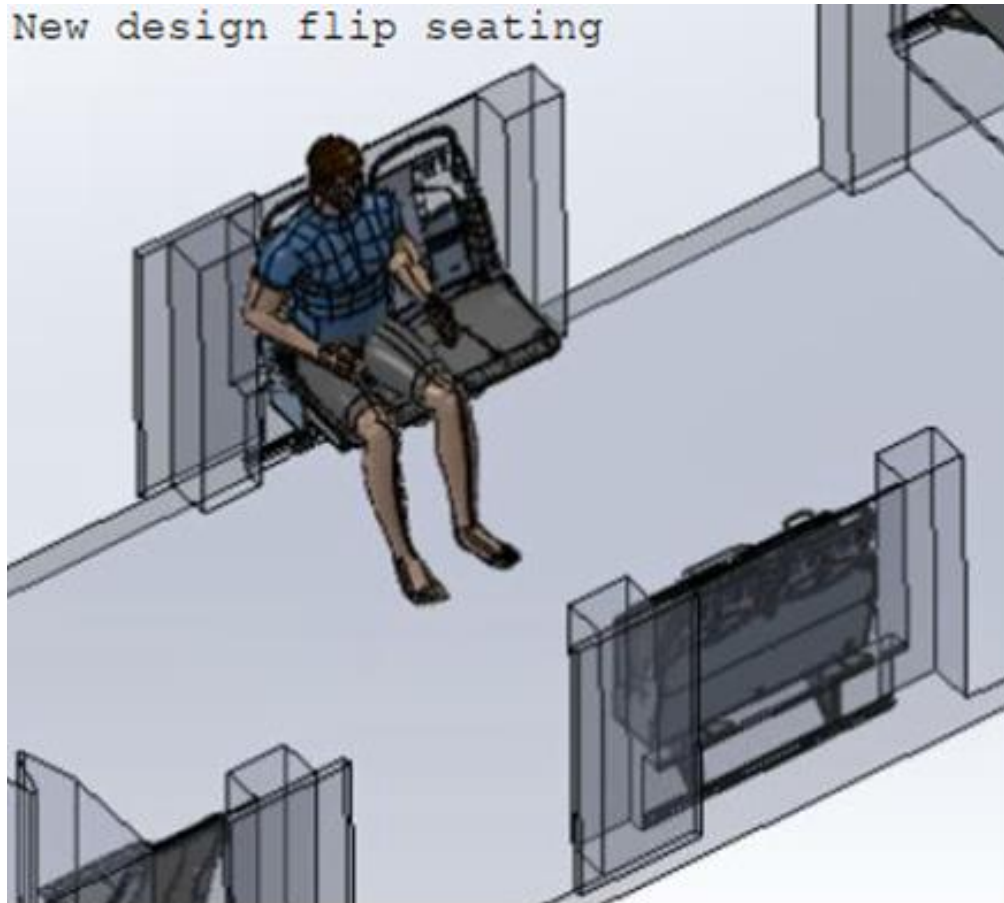

- The new longitudinal flip seating configuration reduces passenger leg protrusion into the LRV doorway
- This change adds two additional 30" x 48" ADA areas per vehicle



Vertical Comparison Old Vs New Design

Existing Back-to-back Seating

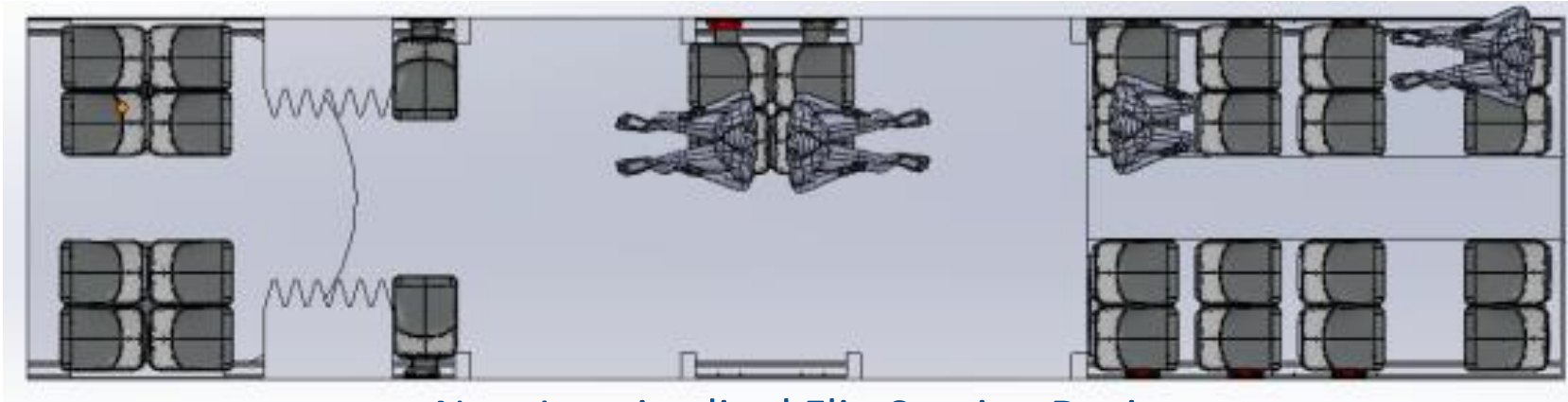

New Longitudinal Flip Seating Design

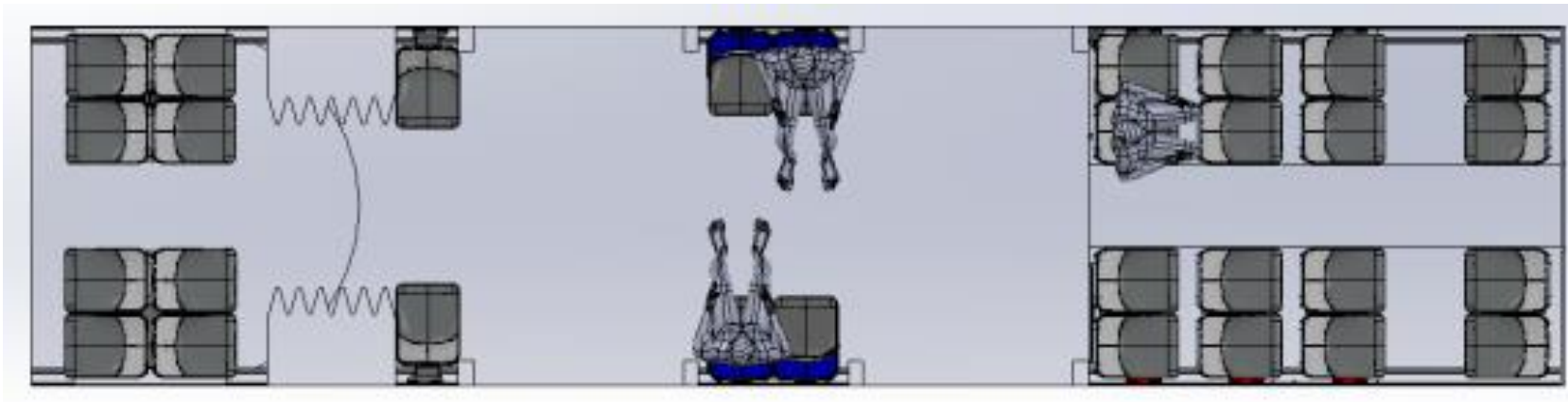

New Seat Barrier & Ingress/Egress Grab Handle



Barrier Seat Structure

Grab Handle

- The new grab handle structure complies with APTA regulations
- New stainless steel grab handle structure for the SD100, SD160, S70 Light Rail Vehicle fleets



Change Order: SD100/SD160/S70 LRV Seating Replacement Contract Modification 1 (United Safety and Survivability Corporation)

Recommended Action (by acclamation)

Motion to approve Modification 1 to the contract with United Safety and Survivability Corporation for the SD100/SD160/S70 LRV seating replacement, as presented



Change Order: Microtransit Master Service Agreement Service Order No. 3 – UTA On Demand Southern Davis County (River North Transit LLC “Via”)

Recommended Action (by acclamation)

Motion to approve Service Order No. 3 to the contract with River North Transit LLC “Via” for UTA On Demand in southern Davis County, as presented



Pre-Procurements

- Fuel Card Program
- TechLink Corridor Study



Service and Fare Approvals



Fare Agreement: Education Pass (Salt Lake School District and Salt Lake Education Foundation)

Recommended Action (by acclamation)

Motion to approve the education pass fare agreement with Salt Lake School District and Salt Lake Education Foundation, as presented



Fare Agreement: Funding for Salt Lake School District Passes (Salt Lake City Corporation)

Recommended Action (by acclamation)

Motion to approve the fare agreement with Salt Lake City Corporation for funding for Salt Lake School District passes, as presented



Fare Agreement: Education Pass (Charter School Consortium)

Recommended Action (by acclamation)

Motion to approve the education pass fare agreement with Charter School Consortium, as presented



Fare Agreement: Education Pass (Mountainland Technical College)

Recommended Action (by acclamation)

Motion to approve the education pass fare agreement with Mountainland Technical College, as presented



Fare Agreement: Education Pass (Salt Lake Community College)

Recommended Action (by acclamation)

Motion to approve the education pass fare agreement with Salt Lake Community College, as presented



Fare Agreement: Education Pass (University of Utah)

Recommended Action (by acclamation)

Motion to approve the education pass fare agreement with University of Utah, as presented



Fare Agreement: Education Pass (Weber State University)

Recommended Action (by acclamation)

Motion to approve the education pass fare agreement with Weber State University, as presented



Fare Agreement: Trip-Based Education Pass – Modification No. 2 (Westminster College)

Recommended Action (by acclamation)

Motion to approve Modification No. 2 to the trip-based education pass fare agreement with Westminster College, as presented



Other Business

- a. Next Meeting: Wednesday, July 27th, 2022 at 9:00 a.m.



In Memoriam: Candice Hamilton



In Memoriam: Andrew Fetzer



Adjourn

