

# UTA Board of Trustees Meeting

September 11, 2024



# Call to Order and Opening Remarks



# Pledge of Allegiance



# Safety First Minute



# Public Comment

- Live comments are limited to 3 minutes per commenter
- Live comments may be heard from in-person attendees as well as Zoom attendees
- For comments via Zoom, use the “raise hand” function in Zoom to indicate you would like to make a comment
- Public comment was solicited prior to the meeting through alternate means, including email, telephone, and the UTA website
- Any comments received through alternate means were distributed to the board for review in advance of the meeting



# Consent Agenda

- a. Approval of August 5, 2024, Board of Trustees Budget Work Session Minutes
- b. Approval of August 6, 2024, Board of Trustees Budget Work Session Minutes
- c. Approval of August 7, 2024, Board of Trustees Budget Work Session Minutes
- d. Approval of August 8, 2024, Board of Trustees Budget Work Session Minutes
- e. Approval of August 9, 2024, Board of Trustees Budget Work Session Minutes
- f. Approval of August 16, 2024, Board of Trustees Budget Work Session Minutes
- g. Approval of August 14, 2024, Board Meeting Minutes



# **Recommended Action**

## **(by acclamation)**

Motion to approve the consent agenda



# Reports



# Executive Director Report



# UTA Recognition - TRAX Ambassadors





## TRAX Ambassador Team Recognition:

TJ Aiolupotea

Marcy Richards

Kylee-Amber Sykes



# **Continuous Improvement Excellence Award**

## **Meadowbrook Maintenance**



UTA 

CI  
EXCELLENCE  
AWARD





# Meadowbrook Maintenance

a 4-year journey

## Problem

- **Suboptimal Working Conditions**  
*(Dark, Dingy, Unsafe, High Turnover)*

## Solution

- CI training & teamwork
- 100+ ideas implemented
- **Major Shop Improvements** to brake pits, wash bays, warehouse, fluids and more

## Results

**100%**

retention in 2024

**2X**

productivity

Agenda Item 6.a.

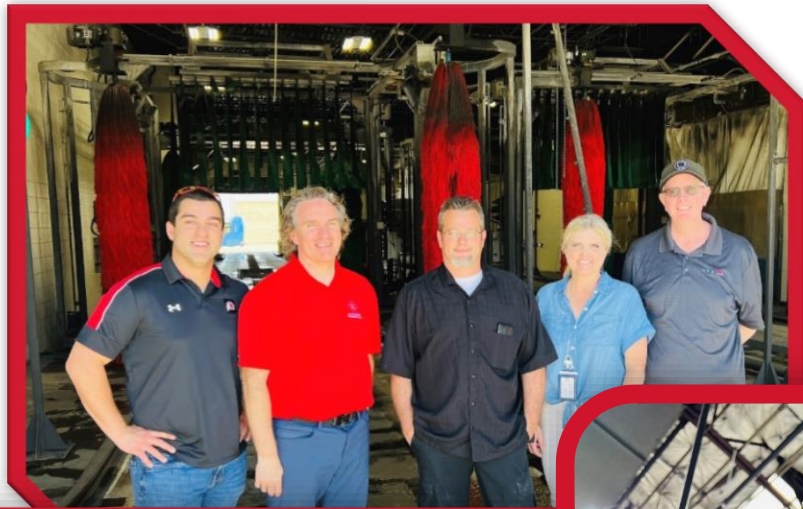



# Meadowbrook 3D Printing

## Problem

- Safety issues due to seat belt alarms breaking

## Solution

- Created a 3D printed alarm cover
- Designed multiple iterations
- **Eliminated waste** and improved **driver safety**

## Results

**\$4,074**

in annual  
savings

**NO**

damaged alarms  
since implementation

**before**



**after**

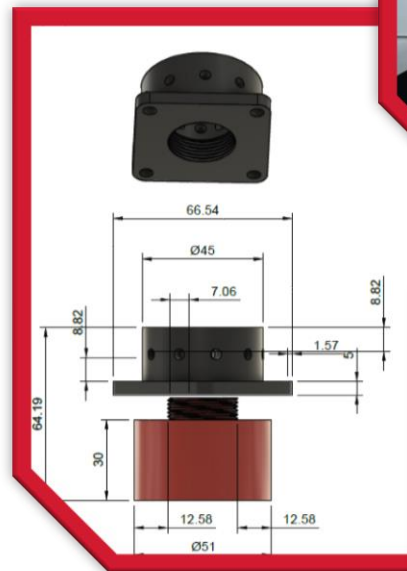

# Strategic Plan Minute





# Strategic Plan Minute

9/11/24



**Agenda Item 6.b.**



## Building Community Support

# Strategic Communications Plan

- Finalized UTA Strategic Communications Plan
- Hired a UTA Public Information Officer
- Increased UTA storytelling via social media

YouTube

Search



An Unprecedented Study: Monitoring Air Quality Using TRAX and Electric Buses



Utah Transit Authority

7,964 followers

2w · 🌐

Last week, UTA celebrated the 34th anniversary of the Americans with Disabilities Act (ADA). This groundbreaking legislation continues to empower members of the disability community with equal access and opportunity and remains a cornerstone of civil rights in the U.S.

To better meet the needs of our community members, UTA has created a citizen advisory group called the Committee on Accessible Transportation (CAT). The CAT plays a crucial role in advising UTA on accessibility issues within our system. Members' unique perspectives and insights are instrumental in our continuous efforts to improve rider experiences, making each journey more comfortable and enjoyable.

[#ADA34](#) [#WeMoveYou](#) [#RideUTA](#)  
[#americanswithdisabilitiesact](#)



# Financial Report – July 2024



# Monthly Operating Financial Report July 2024

Sep 11, 2024



# Utah Transit Authority

Board Dashboard: July 31, 2024

<b>Financial Metrics</b>	Jul Actual	Jul Budget	Fav / (Unfav)	%	YTD Actual	YTD Budget	Fav / (Unfav)	%
Sales Tax (Jun '24 mm \$)	\$ 40.7	\$ 47.1	\$ (6.43)	-13.6%	\$ 242.4	\$ 236.9	\$ 5.48	2.3%
Fare Revenue (mm)	\$ 3.2	\$ 2.9	\$ 0.26	8.8%	\$ 23.4	\$ 20.5	\$ 2.88	14.0%
Operating Exp (mm)	\$ 37.5	\$ 35.3	\$ (2.22)	-6.3%	\$ 241.9	\$ 247.0	\$ 5.10	2.1%
Subsidy Per Rider (SPR)	\$ 11.25	\$ 12.46	\$ 1.21	9.7%	\$ 9.53	\$ 10.78	\$ 1.25	11.6%
UTA Diesel Price (\$/gal)	\$ 2.59	\$ 4.03	\$ 1.44	35.7%	\$ 2.67	\$ 4.03	\$ 1.36	33.7%
<b>Operating Metrics</b>	Jul Actual	Jul-23	F / (UF)	%	YTD Actual	YTD 2023	F / (UF)	%
Ridership (mm)	3.05	2.54	0.5	20.1%	22.93	19.34	3.6	18.6%
<b>Energy Cost by Type (Monthly Avg YTD)</b>								
	<b>Diesel Bus</b> (Cost per Mile)				\$ 0.54			
	<b>Diesel CR</b> (Cost per Mile)				\$ 4.55			
	<b>Unleaded Gas</b> (Cost per Mile)				\$ 0.34			
	<b>CNG</b> (Cost per Mile)				\$ 0.26			
	<b>Bus Propulsion Power</b> (Cost per Mile)				\$ 0.93			
	<b>TRAX Propulsion Power</b> (Cost per Mile)				\$ 0.92			

"Sales Tax" lists the amount of sales tax revenue received for the month listed in bold. All other data reflects the month listed in the table title.

# 2024 Sales Tax

June YTD Variance \$5.5M / 2.3% Above Budget

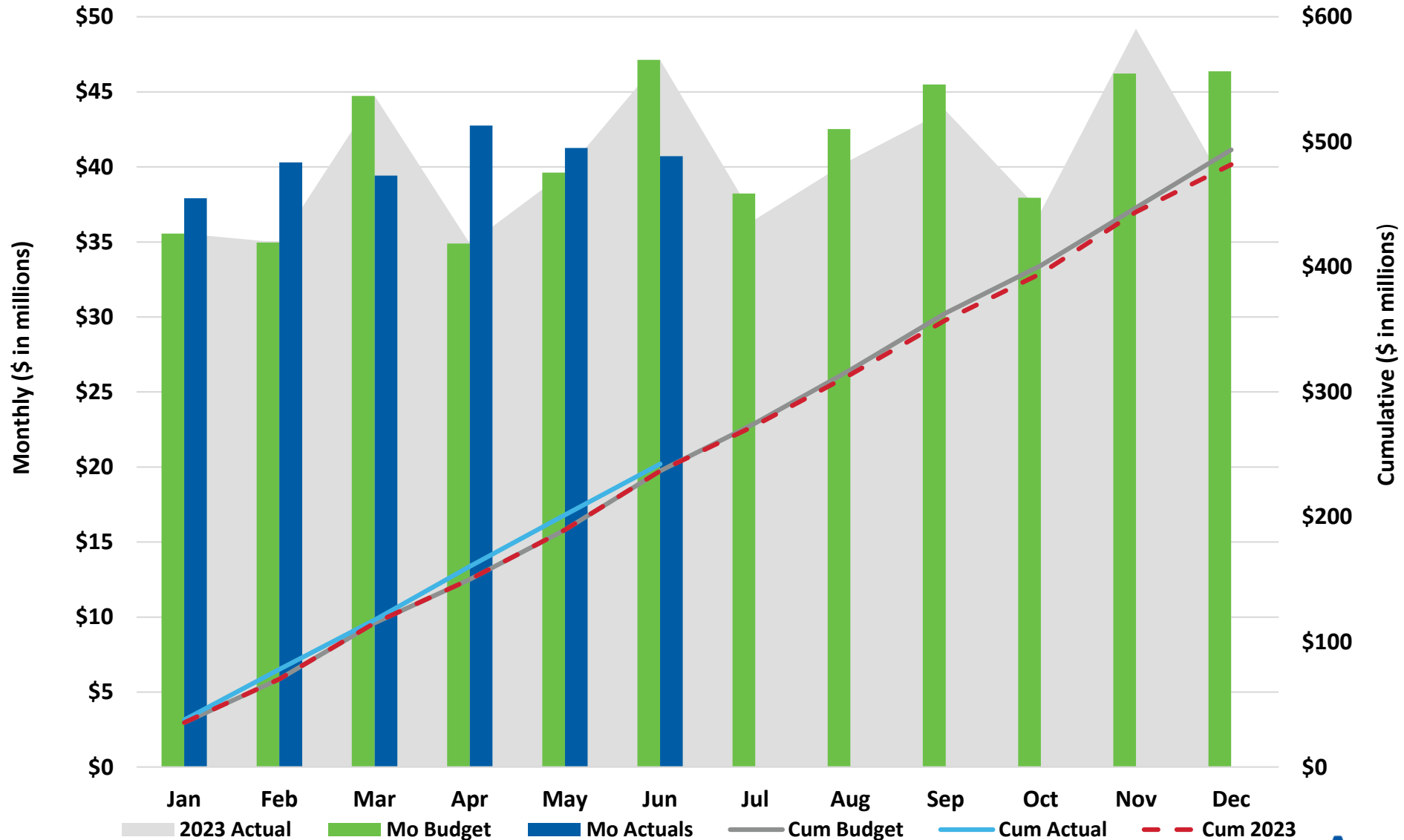

# Sales Tax Collections

## Percentage Change for 12 months ended June 30, 2024

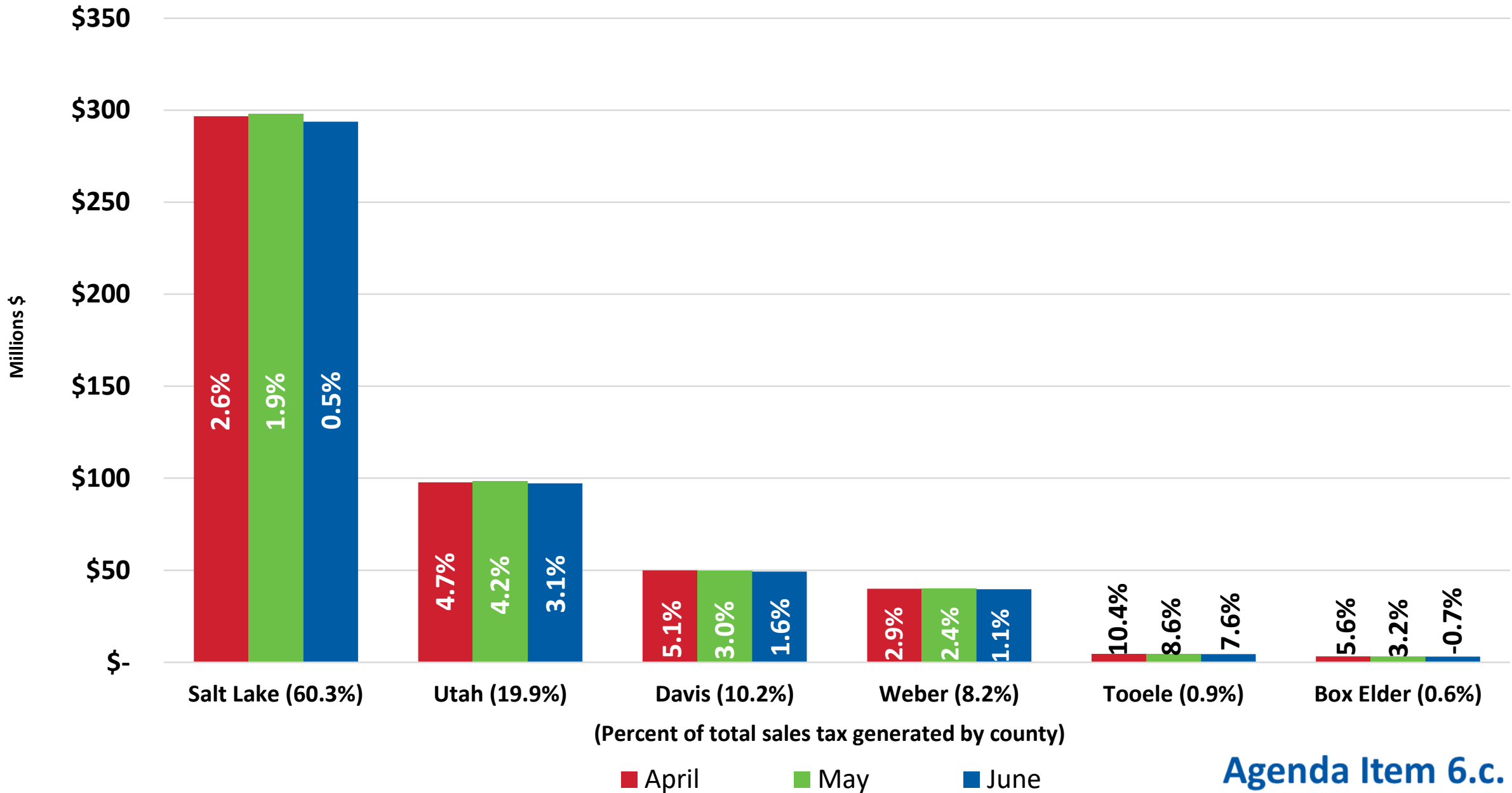

# UTA Sales Tax Growth 2020 - 2024

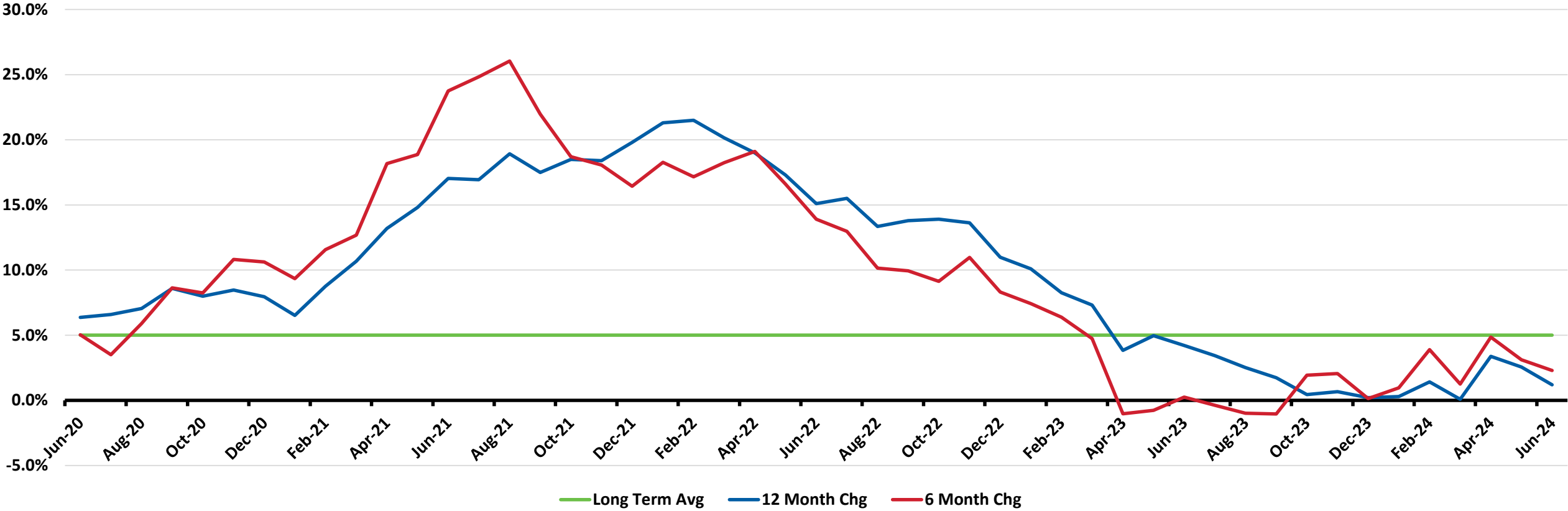

# 2024 Passenger Revenue

## July YTD \$2.9M / 14.0% > Budget

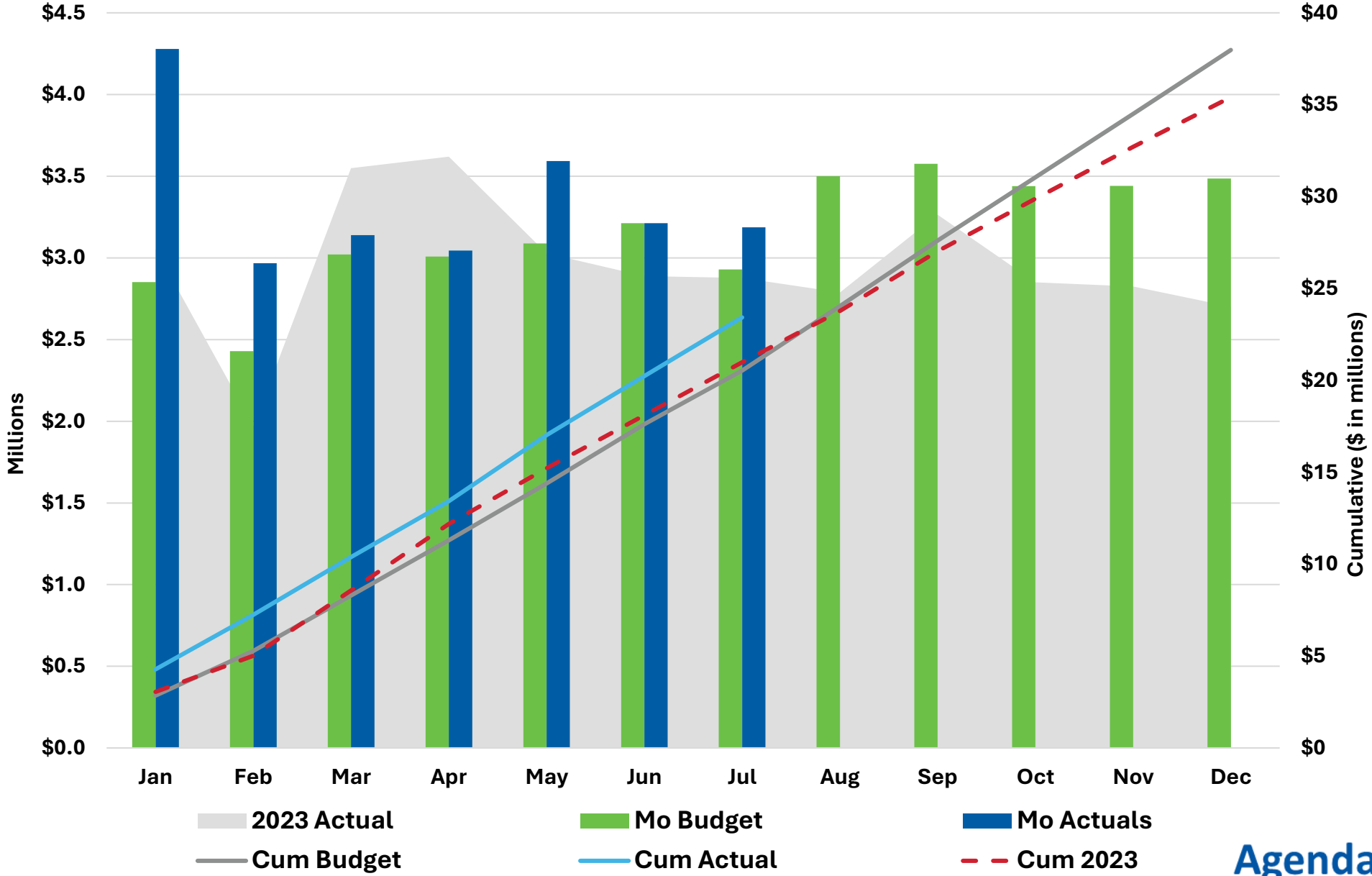

# FTE Report: July 2024



## FTE Report

Jul-24

		Jul-24 Budget vs. Actual			Vacancy Rate		
Administrative FTE	Budget	Actual	Variance	Vacancy	Prior Month	Start of Year	Prior Year
				Rate			
Admin Depts	633.9	606.5	27.4	4.3%	5.2%	7.1%	8.0%
Operating Depts	384.0	376.0	8.0	2.1%	2.0%	2.5%	3.9%
<b>Subtotal</b>	<b>1,017.9</b>	<b>982.5</b>	<b>35.4</b>	<b>3.5%</b>	<b>4.0%</b>	<b>5.4%</b>	<b>6.5%</b>

		Vacancy			Prior Month	Start of Year	Prior Year
Bargaining Unit FTE	Budget	Actual	Variance	Rate			
Admin Depts	47.0	83.0	-36.0	-76.6%	-114.9%	-54.8%	-177.4%
<i>Operating Modes</i>							
Bus	1,078.0	1,129.5	-51.5	-4.8%	-3.0%	3.5%	11.6%
Light Rail	285.0	284.0	1.0	0.4%	0.7%	-4.9%	2.5%
Commuter Rail	103.0	114.0	-11.0	-10.7%	-8.7%	3.9%	-2.9%
Riverside	157.0	153.5	3.5	2.2%	4.1%	4.7%	4.7%
Asset Mgt	186.0	166.0	20.0	10.8%	10.2%	11.4%	12.5%
<b>Subtotal</b>	<b>1,856.0</b>	<b>1,930.0</b>	<b>-74.0</b>	<b>-4.0%</b>	<b>-3.7%</b>	<b>1.8%</b>	<b>8.8%</b>

<b>Total FTE</b>	<b>2,873.9</b>	<b>2,912.5</b>	<b>-38.6</b>	<b>-1.3%</b>	<b>-1.0%</b>	<b>3.0%</b>	<b>8.0%</b>
------------------	----------------	----------------	--------------	--------------	--------------	-------------	-------------

Agenda Item 6.c.

# July 2024 YTD Financial Results



## OPERATING FINANCIALS

July 2024 YTD

FISCAL YEAR 2024 Dollars In Millions	YEAR-TO-DATE RESULTS					
	Prior Year Actual	Current Year				
		Actual	Budget	Variance		
<b>Revenue</b>						
Sales Tax (July accrual)	\$ 273.3	\$ 284.7	\$ 275.4	\$ 9.2	3.3%	
Fares	21.0	23.4	20.5	2.9	14.0%	
Federal	38.8	4.9	48.0	(43.1)	-89.7%	
Other *	28.7	54.3	13.1	41.2	314.9%	
<b>TOTAL REVENUE</b>	<b>\$ 361.8</b>	<b>\$ 367.3</b>	<b>\$ 357.1</b>	<b>\$ 10.2</b>	<b>2.9%</b>	
<b>Expense</b>						
Salary/Wages	\$ 101.2	\$ 111.4	\$ 109.1	\$ (2.3)	-2.1%	
Overtime	9.1	8.4	7.9	(0.4)	-5.5%	
Fringe Benefits	51.6	58.6	58.3	(0.3)	-0.6%	
<b>Total Compensation</b>	<b>\$ 161.9</b>	<b>\$ 178.4</b>	<b>\$ 175.3</b>	<b>\$ (3.1)</b>	<b>-1.8%</b>	
Services	21.8	22.3	26.0	3.6	14.1%	
Parts	14.3	15.3	15.1	(0.2)	-1.4%	
Fuel	16.7	16.4	20.7	4.3	20.8%	
Utilities	5.0	4.2	4.5	0.3	6.2%	
Other	7.2	12.4	12.7	0.3	2.6%	
Capitalized Cost	(7.2)	(7.2)	(7.4)	0.2	-2.4%	
<b>TOTAL EXPENSE</b>	<b>\$ 219.6</b>	<b>\$ 241.9</b>	<b>\$ 247.0</b>	<b>\$ 5.1</b>	<b>2.1%</b>	
Debt Service	46.7	45.7	48.7	3.0	6.1%	
<b>Contrib. Capital/Reserves</b>	<b>\$ 95.5</b>	<b>\$ 79.8</b>	<b>\$ 61.5</b>	<b>\$ 18.3</b>	<b>29.8%</b>	

\*Does not include Sale of Assets (\$961.4K) or Non-Cash items

Favorable/(Unfavorable)

Agenda Item 6.c.

# Questions?



# Capital Program Update July 2024

September 11, 2024



## Utah Transit Authority Capital Program: July 31, 2024

Chief Office	July Actual	July Budget	Variance	%	YTD Actual	YTD Budget	Variance	%
<b>People</b>	\$ 114	\$ 60,000	\$ 59,886.48	● 99.8%	\$ 1,170,127	\$ 1,349,000	\$ 178,873	● 13.3%
<b>Executive Director</b>	35,967	135,000	99,033	● 73.4%	\$ 921,523	\$ 1,293,000	371,477	● 28.7%
<b>Planning &amp; Engagement</b>	270,802	393,000	122,198	● 31.1%	\$ 1,957,874	\$ 2,445,000	487,126	● 19.9%
<b>Operations</b>	418,397	655,000	236,603	● 36.1%	\$ 2,264,327	\$ 3,082,000	817,673	● 26.5%
<b>Enterprise Strategy</b>	322,234	789,000	466,766	● 59.2%	\$ 2,028,031	\$ 3,407,000	1,378,969	● 40.5%
<b>Finance</b>	705,886	1,221,000	515,114	● 42.2%	\$ 12,560,410	\$ 17,375,000	4,814,590	● 27.7%
<b>Capital Services</b>	13,448,657	15,729,000	2,280,343	● 14.5%	\$ 54,348,547	\$ 67,017,000	12,668,453	● 18.9%
<b>Total</b>	\$ 15,202,058	\$ 18,982,000	\$ 3,779,942	● 19.9%	\$ 75,250,838	\$ 95,968,000	\$ 20,717,162	● 21.6%



### July YTD Capital Spend

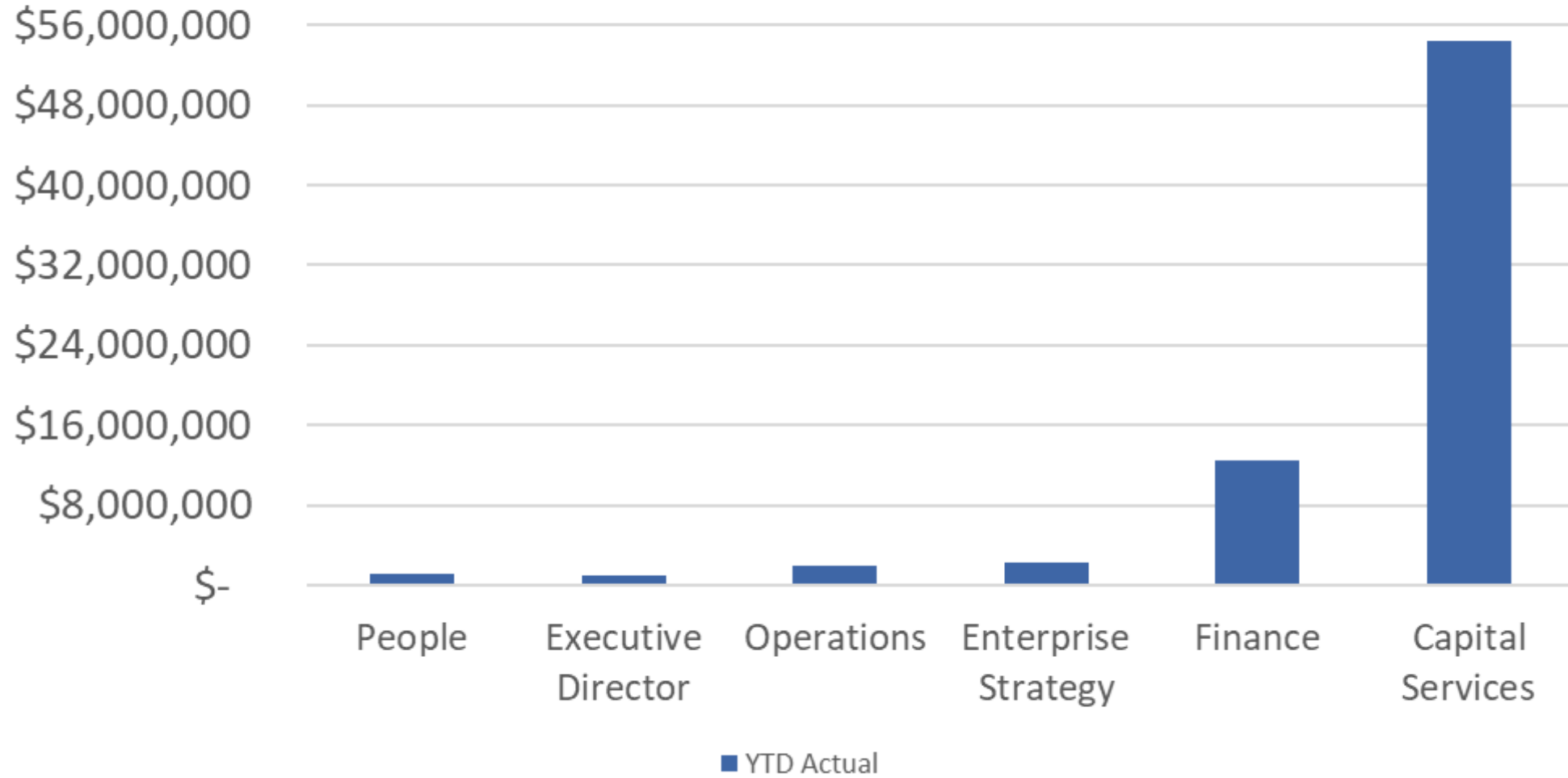

# Questions?



# Resolutions



**R2024-09-01 - Resolution Authorizing the  
Execution of Federal Transit Administration 5310  
Subrecipient Grant Agreements**



# Coordinated Mobility: Summary of Request

- Requesting approval to process and execute 5310 subrecipient agreements upon the award of Federal Transit Administration 5310 Program Grant Agreements as listed in Exhibit A of Resolution R2024-09-01.



# Coordinated Mobility

- The subrecipient projects are being funded with new grant awards for FFY 2023 and FFY 2024.
- Of the 14 agreements to be signed, 10 of the subrecipient projects are above \$200K total project budget.

Information regarding the FTA  
Section 5310 Program can be  
found at [www.rideuta.com/cmm](http://www.rideuta.com/cmm)



# Summary of Agencies and Projects to be Funded

Agency	Project Description	Total Budget
Utah Valley Rides	Operating assistance, preventive maintenance, supplies	\$123,110
Utah's Promise	Mobility management	\$322,300
TURN Community Services	4 vans, operating assistance, 3 <sup>rd</sup> party contracts, preventive maintenance	\$991,578
Suzy's Senior Services	Operating assistance, preventive maintenance, 3 vans, 2 sedans, office supplies	\$1,052,486
PARC	Operating assistance, preventive maintenance, 1 van	\$382,996
Ability Inclusion Services (Work Activity Center)	Operating assistance, preventive maintenance, 1 van	\$215,000



# Summary of Agencies and Projects to be Funded

Agency	Project Description	Total Budget
Neighborhood House	Operating assistance, preventive maintenance, 1 van	\$357,208
Odyssey House	Operating assistance	\$66,400
Bear-O-Care	Operating, 1 van, 1 cutaway bus, preventive maintenance	\$361,000
The Road Home	Operating assistance	\$24,000
First Step House	2 vans, 5 minivans, operating assistance, preventive maintenance	\$662,800
Salt Lake County Aging	3 <sup>rd</sup> party contracts, operating assistance	\$325,000
Payson City	1 Cutaway bus	\$150,000
Kostopolus Dream Foundation	Operating assistance, security equipment	\$361,652

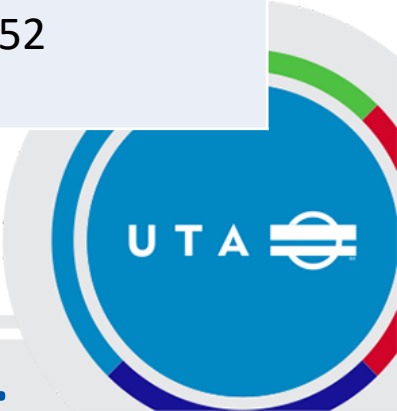

# Summary of UTA Projects Being Funded

Agency – Project Type	Project Description	Federal	UTA Local Share	Total Budget
UTA Travel Training	Travel trainer salary	\$245,320	\$61,330	\$306,650
UTA Mobility Management	Call referral program for urgent trips	\$207,136	\$51,784	\$258,920
UTA RidePilot Lite	Updates to our subrecipient vehicle tracking software	\$8,420	\$2,105	\$10,525



# Budget Impact

- All grant funding is included in the 2024 Approved Budget
- This has a net zero impact on the budget as all matching funds are provided by community partners, UTA in-kind staff time, and appropriated legislative funding.



# Questions?



# Recommended Action

(by roll call)

Motion to approve R2024-09-01 – Resolution Authorizing the Execution of Federal Transit Administration 5310 Subrecipient Grant Agreements, as presented



# Contracts, Disbursements, and Grants



# **Contract: Vendor Managed Shop Supplies (Grainger Inc.)**

---

## **Recommended Action (by acclamation)**

Motion to approve the contract with Grainger Inc.  
for Vendor Managed Shop Supplies, as presented



# **Contract: Farmington to Bountiful Bus Stop Improvements - Phase 1 (Landmark Companies, Inc.)**

---

## **Recommended Action (by acclamation)**

Motion to approve the contract with Landmark Companies, Inc. for Farmington to Bountiful Bus Stop Improvements - Phase 1, as presented



# **Change Order: On-Call Infrastructure Maintenance Contract Task Order #24-052 - 3300/3500 S. Bus Stops (Stacy and Witbeck, Inc.)**

---

## **Recommended Action (by acclamation)**

Motion to approve task order number 24-052 to the On-Call Infrastructure Maintenance Contract with Stacy and Witbeck, Inc. for 3300/3500 S. Bus Stops, as presented



# **Change Order: 200 South Bus Stop Shelter Installation**

## **Change Order #02 - Phase II**

### **(Landmark Companies, Inc.)**

---

### **Recommended Action**

#### **(by acclamation)**

Motion to approve Change Order #2 to the 200 South Bus Stop Shelter Installation contract with Landmark Companies, Inc. for Phase II, as presented



# **Change Order: Facility Remodel and Reconfiguration Services Contract Task Order #24-001 - Depot District Restroom Remodel (Paulsen Construction)**

---

## **Recommended Action (by acclamation)**

Motion to approve Task Order #24-001 to the Facility Remodel and Reconfiguration Services Contract with Paulsen Construction for the Depot District Restroom Remodel, as presented



# **Change Order: UTA Headquarters and Salt Lake Central Redevelopment Design Services Change Order 1 - Schematic Design Phase I (Skidmore, Owings & Merrill LLP)**

---

## **Recommended Action (by acclamation)**

Motion to approve Change Order 1 to the UTA Headquarters and Salt Lake Central Redevelopment Design Services contract with Skidmore, Owings & Merrill LLP for Schematic Design Phase I, as presented



# NEXT STEPS



## Schematic (30%) Design

Refines design assumptions

- Space program and layout
- Major building systems
- Site design
- Materials and finishes

## Allows Project Team to:

Refine Financial Strategy

- Verify costs
- Value engineer
- Explore funding sources

Define delivery timeline

Engage potential lenders and tenants



# **Change Order: UTA Headquarters and Salt Lake Central Redevelopment Design Services Change Order 1 - Schematic Design Phase I (Skidmore, Owings & Merrill LLP)**

---

## **Recommended Action (by acclamation)**

Motion to approve Change Order 1 to the UTA Headquarters and Salt Lake Central Redevelopment Design Services contract with Skidmore, Owings & Merrill LLP for Schematic Design Phase I, as presented



# **Change Order: Banking Services Contract Modification 1 - Exercise Option Years (Zions Bank)**

---

## **Recommended Action (by acclamation)**

Motion to approve Modification 1 to the Banking Services Contract with Zions Bank to Exercise Option Years, as presented



# Pre-Procurements

- Diesel Fuel and Unleaded Gasoline
- Operator Uniforms
- Wheel Press
- S70 Brake Calipers



# Discussion Items



# 2024 Transit Asset Management Plan - Capital Services



## Summary of Request

- UTA staff will present overview of Transit Asset Management Plan and
- Ask Board of Trustees to authorize Executive Director to sign TAM Plan update as agency's Accountable Executive.



# What is Transit Asset Management?

- FTA Regulation
- Requires transit agencies to plan for maintenance and rehabilitation of assets
- Requirement of all federal grant recipients
- Brief history below:

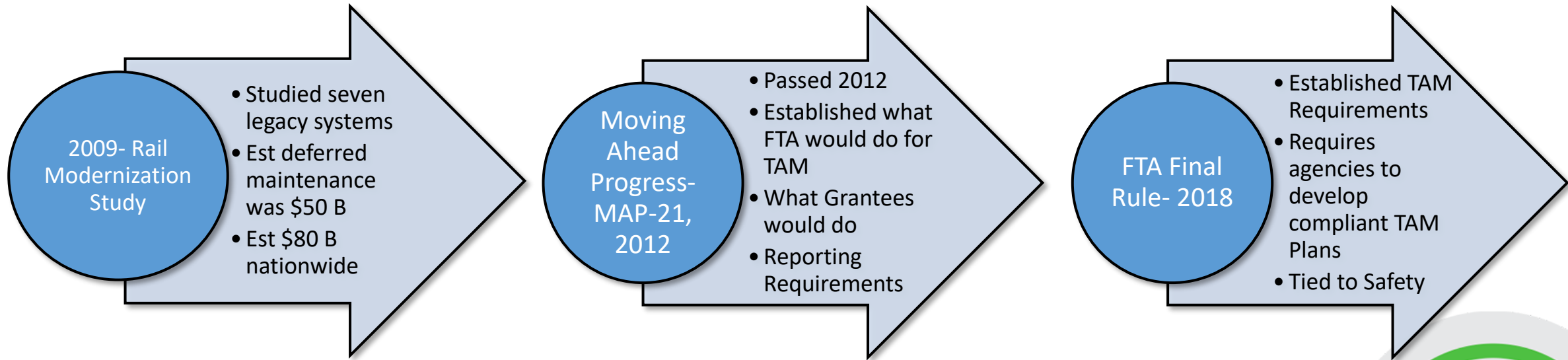

# TAM Plan Requirements

## Tier 1 Agencies

- UTA falls in this group
- Operates  $\geq 101$  vehicles during peak service or
- Provides rail transit
- TAM Plan requires 9 elements
- Update TAM Plan every 4 years

## Tier 2 Agencies

- Operates  $< 101$  vehicles during peak service
- No rail
- Subrecipient under 5311 Rural Formula Program
- TAM Plan requires 4 elements
- Update TAM Plan every 4 years



# TAM Plan Required Elements

- Required Tier 1 TAM Plan Elements:
  - Asset Inventory
  - Condition assessment for all assets
  - Description of process or decision support tool by which agency estimates capital investment needs over time and develops investment prioritization
  - Project-based prioritization of investments
  - Provider's TAM and SGR policy
  - Provider's TAM Plan implementation strategy
  - Description of provider's key TAM activities to be accomplished over next horizon period
  - Summary or list of resources required to develop and implement TAM Plan
  - Outline of how provider monitors and continues to develop TAM Plan and TAM activities



# TAM Plan Asset Inventory

## Infrastructure

- Rail Infrastructure
- BRT Infrastructure
- Systems

## Facilities

- Admin Bldgs
- Maintenance Bldgs
- Passenger Amenities
  - Stations
  - Parking Lots/Structures

## Revenue Vehicles

- Bus
- Paratransit
- Van Pool
- Light Rail
- Commuter Rail
- Microtransit

## Equipment

- Assets >\$50,000
- All Non-Revenue Vehicles



# Condition Assessments

## Age-Based

- Most Common
- Revenue Vehicles
- Equipment

## Condition-Based

- Facility Assets
- Visual Inspection and scoring

## Performance Based

- Infrastructure Assets
- Tied to speed restrictions/slow orders
  - amount of track affected

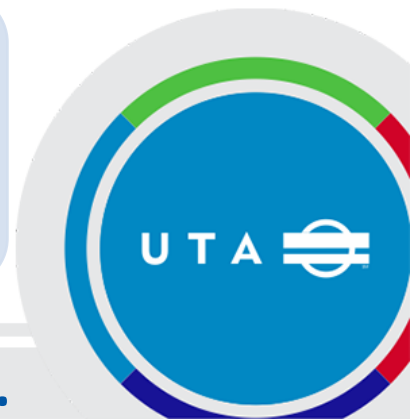

# Description of Process or Decision Support Tool

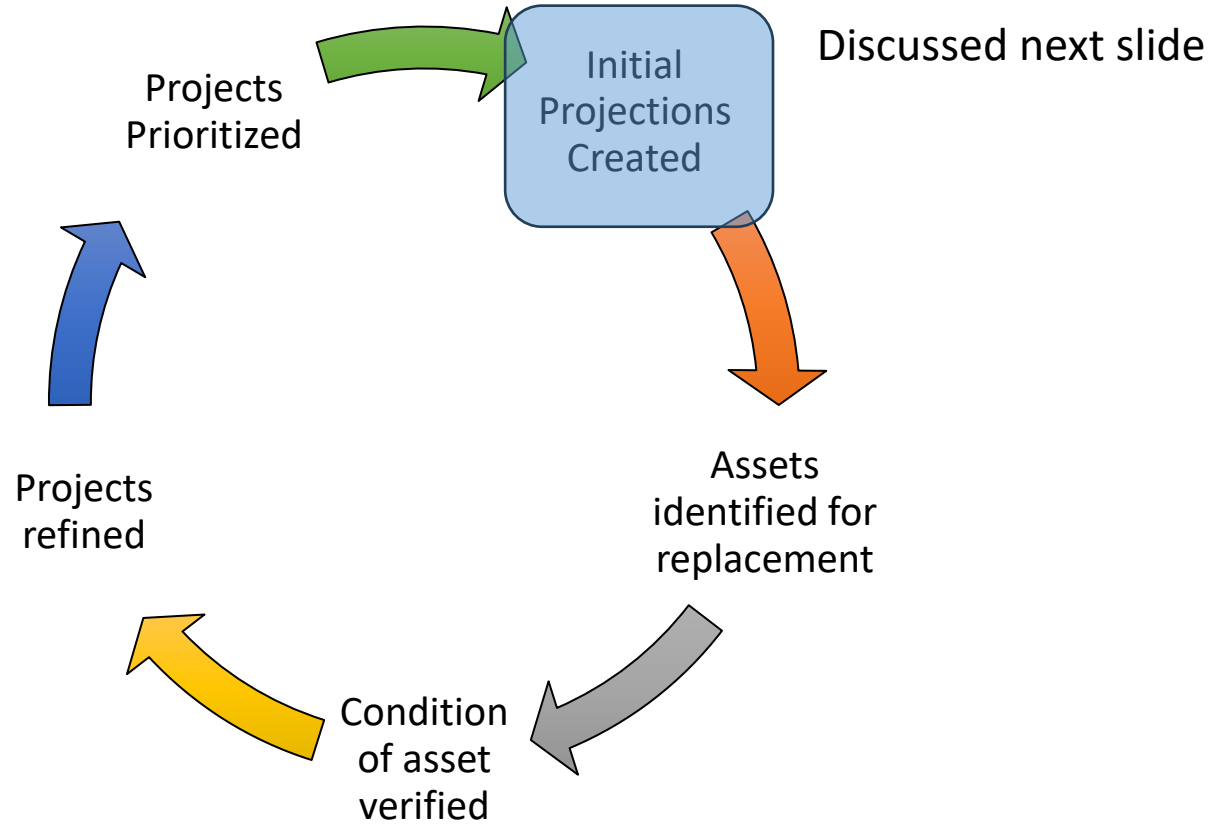

# Project Creation Process

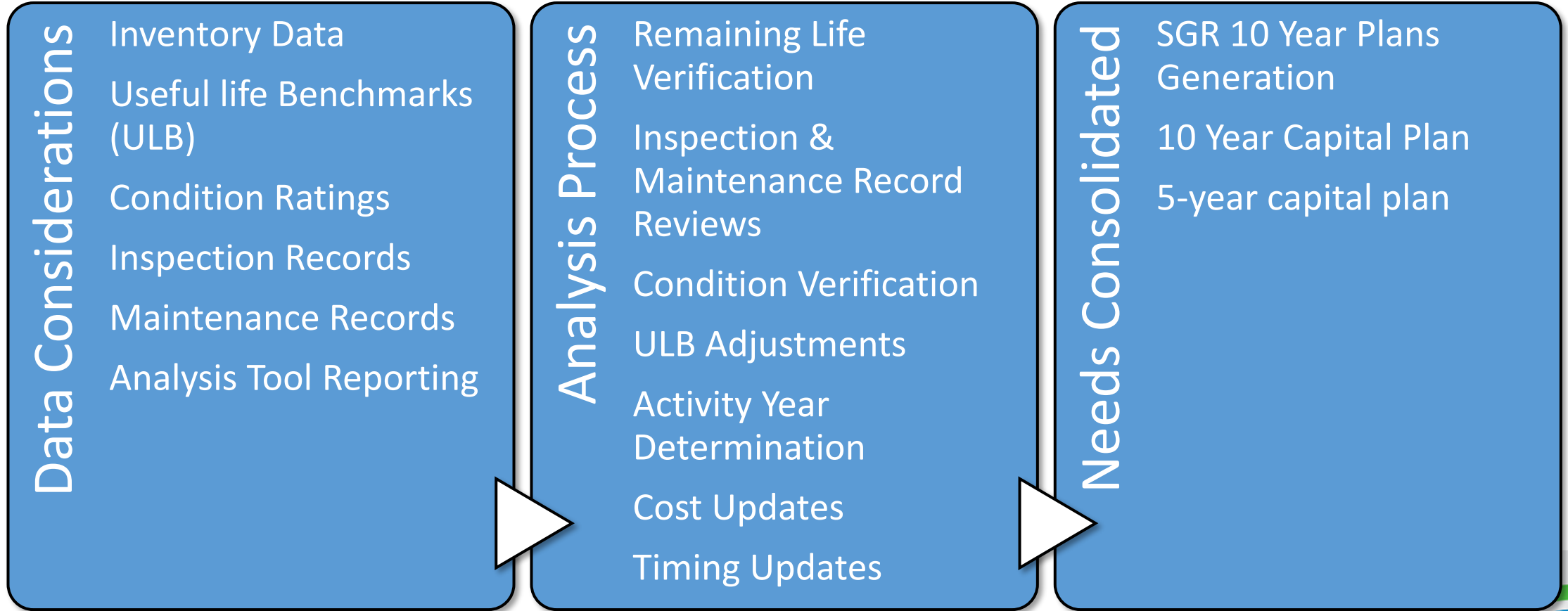

# Project Based Prioritization of Investments - Top 10

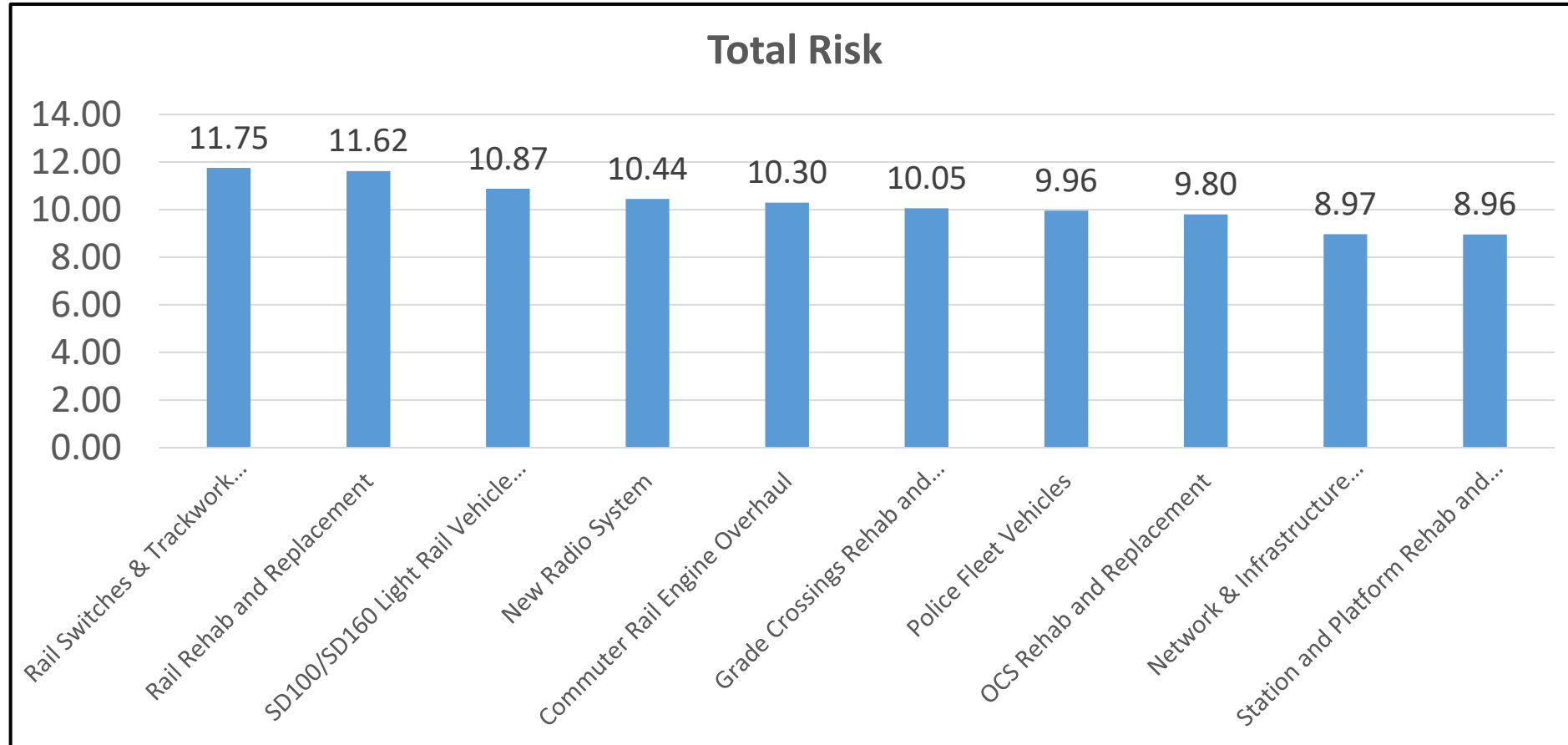

Criteria looks at: public safety, operational performance, quality of life, accessibility, customer experience, age, condition of assets, impact of failure, and likelihood of failure. Also considered against capital prioritization criteria. 44 projects prioritized

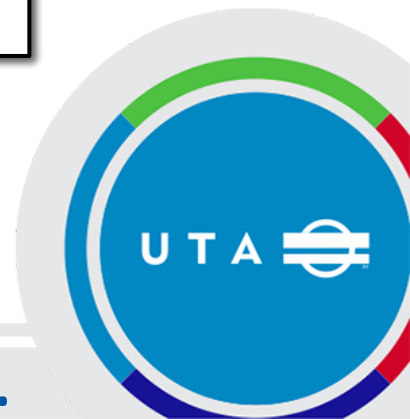

# Agency TAM Policy

UTA's TAM and State of Good Repair (SGR) Policy –

- UTA Policy- UTA.06.01 Transit Asset Management & State of Good Repair Policy
- Reinforces items being discussed here
- Provides framework for collaboration
- Establishes role of Accountable Executive- similar to Transit Agency Safety Plan (TASP)
- Plan should be updated and approved by board every 2 years



# TAM Plan Implementation Strategy

## UTA TAM Program Alignment

Quality of Life

Customer Experience

Organizational Excellence

Community Support

Economic Return



Communication

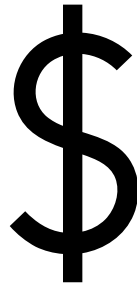

Financially Supported



Realistic Delivery



# Agency Coordination

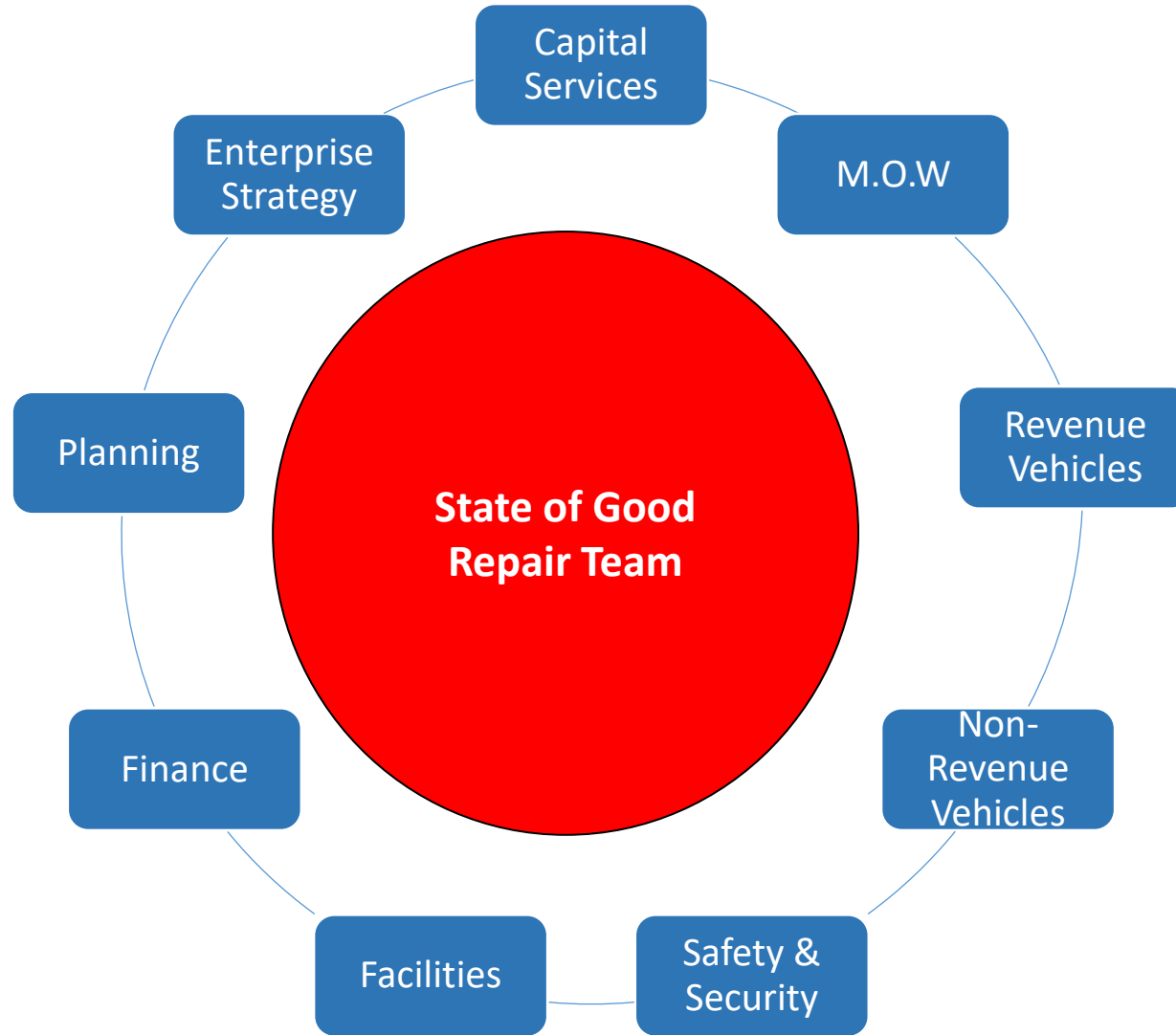

# SGR Plan Amount- \$783.212 M, 66% of upcoming 2025-2029 Plan

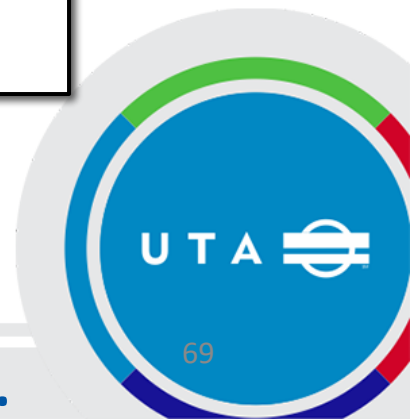
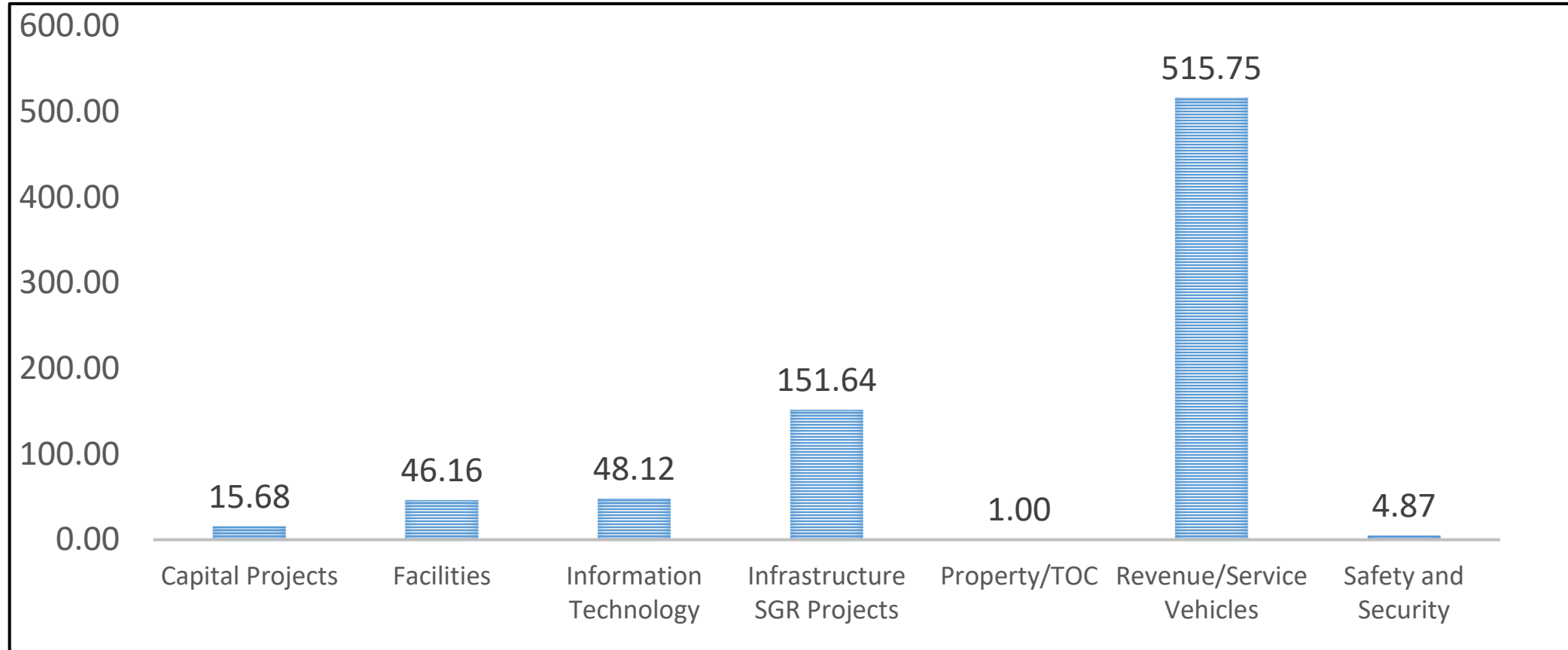

# Key TAM Activities Over Next Horizon Period (coming 4 years)

- 

**Performance Target Setting**

  - Estimating Condition Results of Assets for coming year
  - Shared with MPO's
- 

**National Transit Database (NTD) Reporting**

  - Reports on SGR inventory
  - Reports on Condition Data and
  - Final Performance Target Results
- 

**Five-Year Capital Plan Completion**

  - Assure necessary projects are captured
  - Coordinate with Project Delivery Teams
- 

**Facilities Condition Inspections**

  - 25% of UTA Buildings & Passenger Amenities inspected each year



# Key Projects over next 4 years (Top Ten)

Investment Prioritization Excerpt- SGR Program 2025-2029 Five Year Capital Plan

Project Code	Project Name	Total Risk	Total Rank	2025	2026	2027	2028	2029
SGR404	Rail Switches & Trackwork Controls - Rehab/Replacement	11.75	1	\$ 500,000	\$ 4,500,000	\$ 1,600,000	\$ 1,400,000	
SGR385	Rail Rehab and Replacement	11.62	2	\$ 6,200,000	\$ 2,435,000	\$ 4,500,000	\$ 3,987,000	
REV238	SD100/SD160 Light Rail Vehicle Replacement	10.87	3	\$ 36,000,000	\$ 36,000,000	\$ 37,900,000	\$ 120,000,000	
ICI226	New Radio Communication System	10.44	4	\$ 7,000,000	\$ 500,000	\$ 150,000	\$ 150,000	
SGR353	Commuter Rail Engine Overhaul	10.30	5					
SGR393	Grade Crossings Rehab and Replacement	10.05	6	\$ 4,500,000	\$ 2,200,000	\$ 2,200,000	\$ 4,000,000	
FMA543	Police Fleet Vehicles	9.96	7	\$ 605,000	\$ 605,000	\$ 605,000	\$ 385,000	
SGR398	OCS Rehab and Replacement	9.80	8	\$ 5,900,000	\$ 10,000,000	\$ 10,000,000	\$ 10,000,000	
ICI179	Network & Infrastructure Equipment	8.97	9	\$ 939,000	\$ 279,000	\$ 150,000	\$ 150,000	
FMA673	Station and Platform Rehab and Replacement	8.96	10	\$ 434,000	\$ 200,000	\$ 200,000	\$ 200,000	



# Resources Required to Implement TAM Plan

## People

Board of Trustees

Executive Director

Chief Capital Services Officer

Chief Financial Officer

Capital Services Directors

SGR Manager

Service Units

Facilities Maintenance Manager

Rail Operations Controllers

Procurement

Capital Asset Team

## Technology

JD Edwards

GIS

TERM-Lite

Future- EAM



# UTA's Process for Monitoring/ Continuing Development of TAM Activities

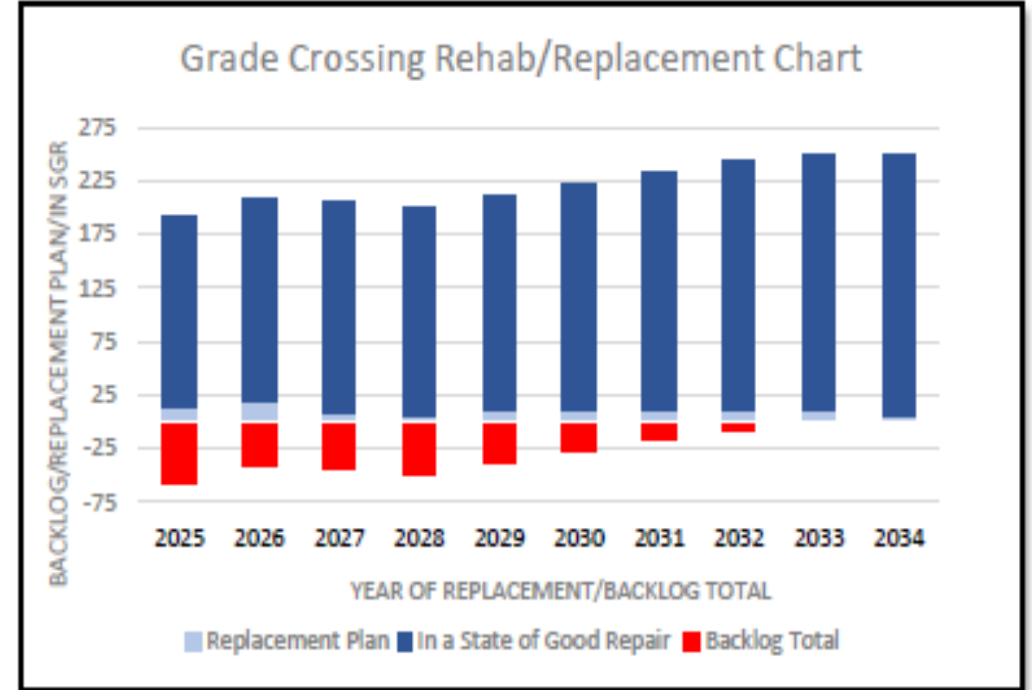
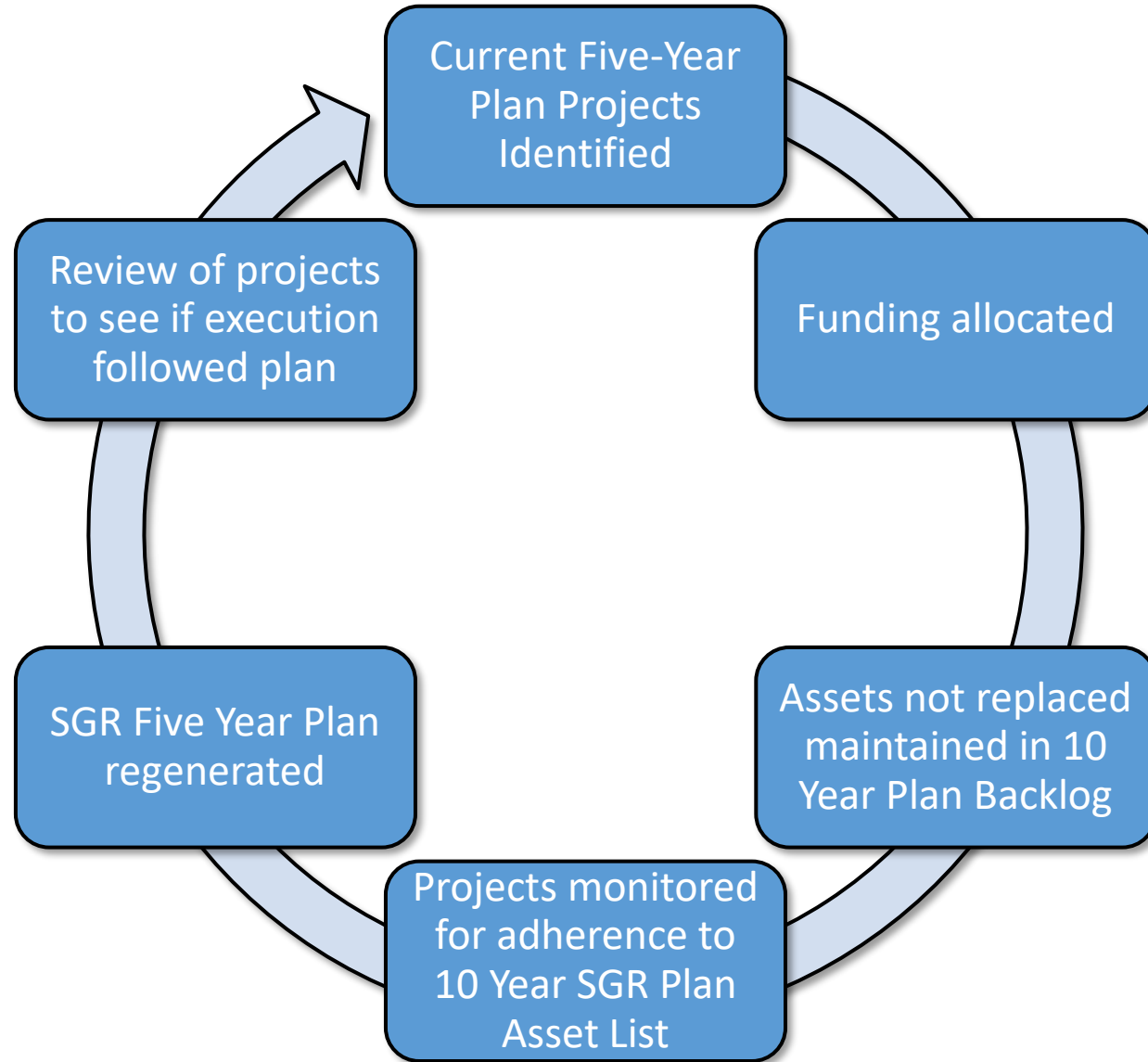

# UTA's Group Transit Asset Management Plan

- Applies to two of UTA's subrecipients
  - Weber Aging Services
  - United Way
- Only requirements for Group Plan are:
  - Inventory of assets meeting thresholds identified earlier
  - Condition assessment
  - Capital Investment needs & prioritization description
  - Project based prioritization of investments
- FTA developed a tool template for Group Plans
- UTA utilizes this tool to generate the required group plans
- UTA Staff meet with group plan members periodically to review group plan progress and update accordingly



## Expectations moving forward

- Presentation every two years:
  - Best time to do it is just after upcoming 5-year Capital plan is approved
- Main body not likely to change much
- Most changes occur in appendices- 5-Year Capital Plan updates yearly
  - Can be changed without Board approval or re-approval of TAM Plan
    - Caveat being if agency goals and objectives change, or major change in project line-up, Board approval would be needed at that time off-cycle
- Approval like Transit Agency Safety Plan (TASP) with Executive Director signing as Accountable Executive



# Questions?



# Proposed Final 2025-2029 Five Year Capital Plan



# Board Strategic Priorities

UTA

## UTA 2024 STRATEGY

**Department:**  
UTA Executive Team

<p><b>Our Vision</b> Leading Utah's mobility solutions and improving quality of life</p>	<p><b>Our Mission</b> We Move You</p>	<p><b>Our Foundation</b> Living and Demonstrating the UTA Way</p>
--	---	---

### BOARD STRATEGIC PRIORITIES & SUCCESS OUTCOMES

**QUALITY OF LIFE**

UTA supports community development, sustainably connecting the Wasatch Front through accessible mobility options, strategic investments, and partnerships.

**CUSTOMER EXPERIENCE**

UTA puts its customers first by providing an easy, enjoyable and accessible transit experience where customers feel engaged, safe and cared about.

**ORGANIZATIONAL EXCELLENCE**

UTA's well-resourced workforce excels, innovates and demonstrates empowerment.

**COMMUNITY SUPPORT**

UTA's communities tell our story and transit is recognized as a keystone to Utah's future growth.

**ECONOMIC RETURN**

UTA is an economic engine which positively impacts Utah's statewide economy, benefiting every Utahn.

### GOALS AND OBJECTIVES

- |   |  |   |  |   |
|---|--|---|--|---|
| <ul style="list-style-type: none"> <li>70% within 1/2 Mile of Service</li> <li>Reduce Footprint by 25%</li> </ul> | <ul style="list-style-type: none"> <li>Increase Net Promoter by 45%</li> <li>Improve Perceived Safety</li> </ul> | <ul style="list-style-type: none"> <li>Recognized as Premier Workplace</li> <li>Increase Improvement Score</li> </ul> | <ul style="list-style-type: none"> <li>100+ Partners Telling Transit Stories</li> <li>Improve Public Satisfaction</li> </ul> | <ul style="list-style-type: none"> <li>Communities See Economic Value</li> <li>Increase Return on Investment</li> </ul> |
|---|--|---|--|---|

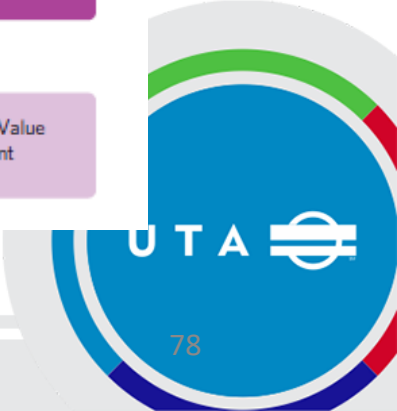

# Agency Goals and Objectives to Delivery

How will UTA deliver on its goals?

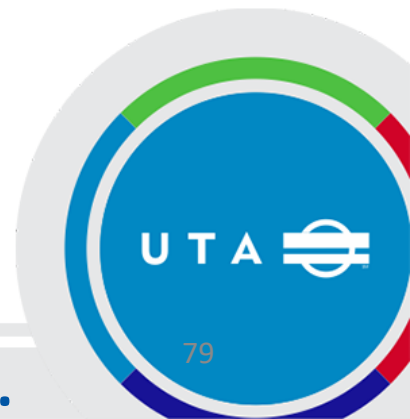

# 2025-2029 Five Year Plan and 2025 Budget Summaries



# New projects (9)

Project	Office	Sum of Total Budget- Rounded
SGR412- PCC Replacement Project	Capital Services	\$4,489,000
FMA696 - Ogden Fueling System Replacement	Capital Services	2,000,000
MSP320- TRAX Modernization Program	Capital Services	500,000
ICI233- Technology Systems- State of Good Repair	Enterprise Strategy	625,000
MSP316 - One-Time Innovative Mobility Zone Funds	Planning & Engagement	400,000
MSP319 - Bus Maintenance Training	People	375,000
MSP318 - MOW Apprenticeship & Training	People	50,000
ICI234 - Coordinated Mobility IT Support	Finance	315,000
ICI235 - ERP Phase 2: Procurement	Finance	300,000
	<b>Total</b>	<b>\$9,054,000</b>

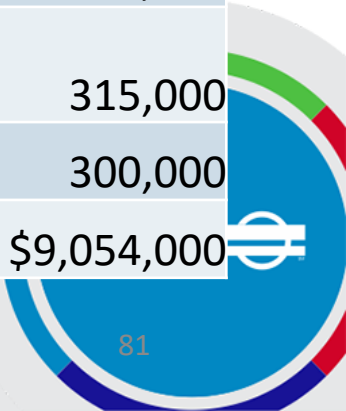

# High-Level Overview

Office	Total 2025-2029 Capital Plan	Number of Projects
Capital Services	\$1,027,705,000	90
Enterprise Strategy	40,917,000	24
Executive Director (Safety)	5,577,000	6
Finance	85,638,000	30
Operations	27,565,000	11
People	2,445,000	5
Planning & Engagement	9,721,000	11
<b>Grand Total</b>	<b>\$ 1,199,568,000</b>	<b>177</b>

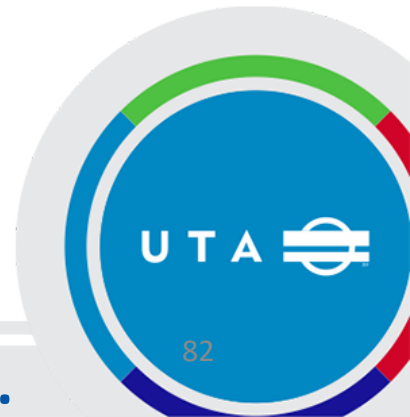

# 2025-2028 High-Level Overview by Office

Sum of Total Budget-Rounded						
Office/Projects	2025	2026	2027	2028	2029	Grand Total
Capital Services	\$276,029,000	\$223,723,000	\$218,018,000	\$170,588,000	\$139,347,000	\$1,027,705,000
Enterprise Strategy	15,809,000	12,623,000	5,275,000	3,930,000	3,280,000	40,917,000
Executive Director (Safety)	1,996,000	1,485,000	756,000	620,000	720,000	5,577,000
Finance	21,211,000	17,868,000	15,532,000	20,543,000	10,484,000	85,638,000
Operations	9,700,000	7,213,000	4,247,000	3,200,000	3,205,000	27,565,000
People	2,145,000	75,000	75,000	75,000	75,000	2,445,000
Planning & Engagement	3,341,000	2,133,000	1,449,000	1,449,000	1,349,000	9,721,000
<b>Grand Total</b>	<b>\$330,231,000</b>	<b>\$265,120,000</b>	<b>\$245,332,000</b>	<b>\$200,405,000</b>	<b>\$158,460,000</b>	<b>\$1,199,568,000</b>



# Funding By Category

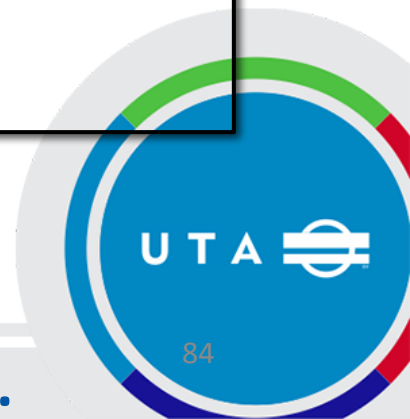
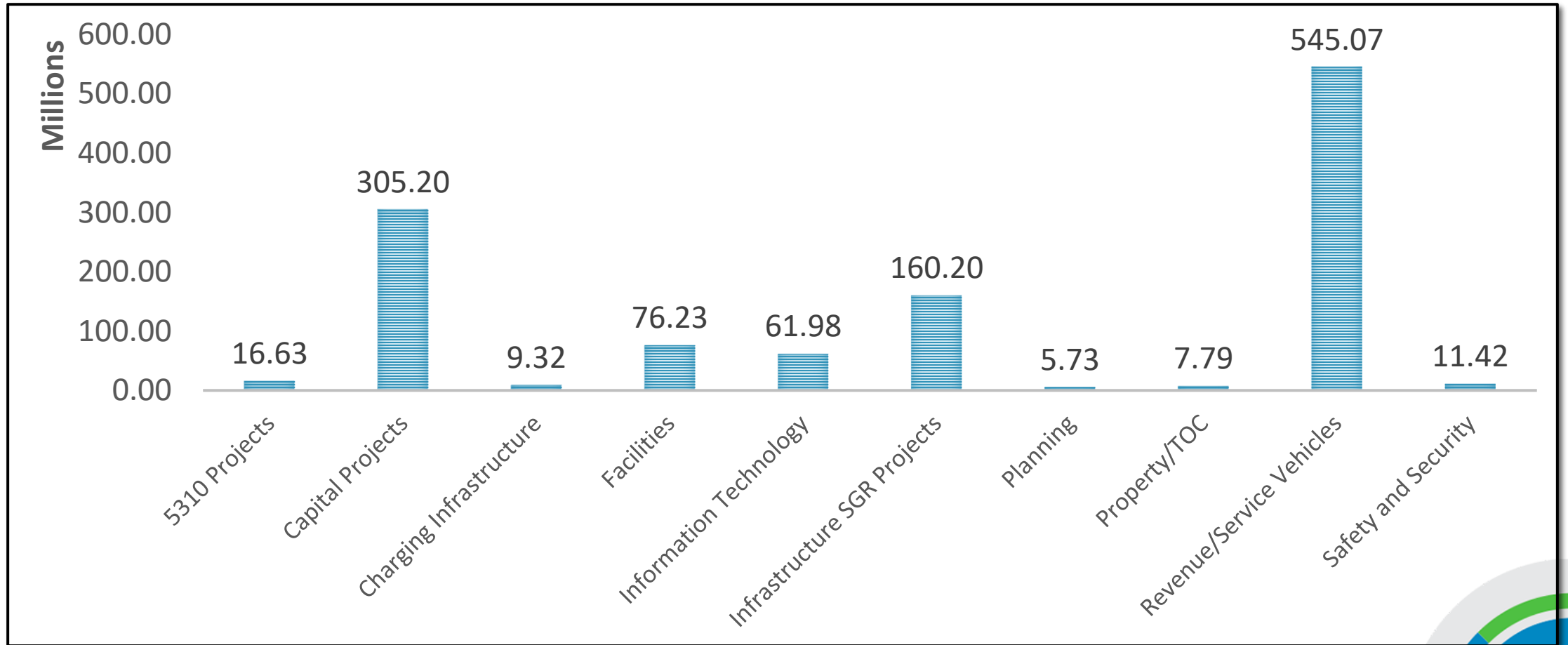

# SGR Plan Amount- \$791.48 M, 66% of Plan

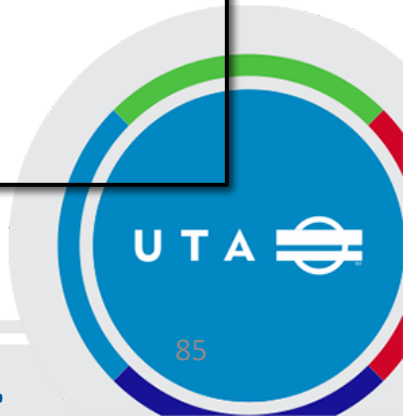
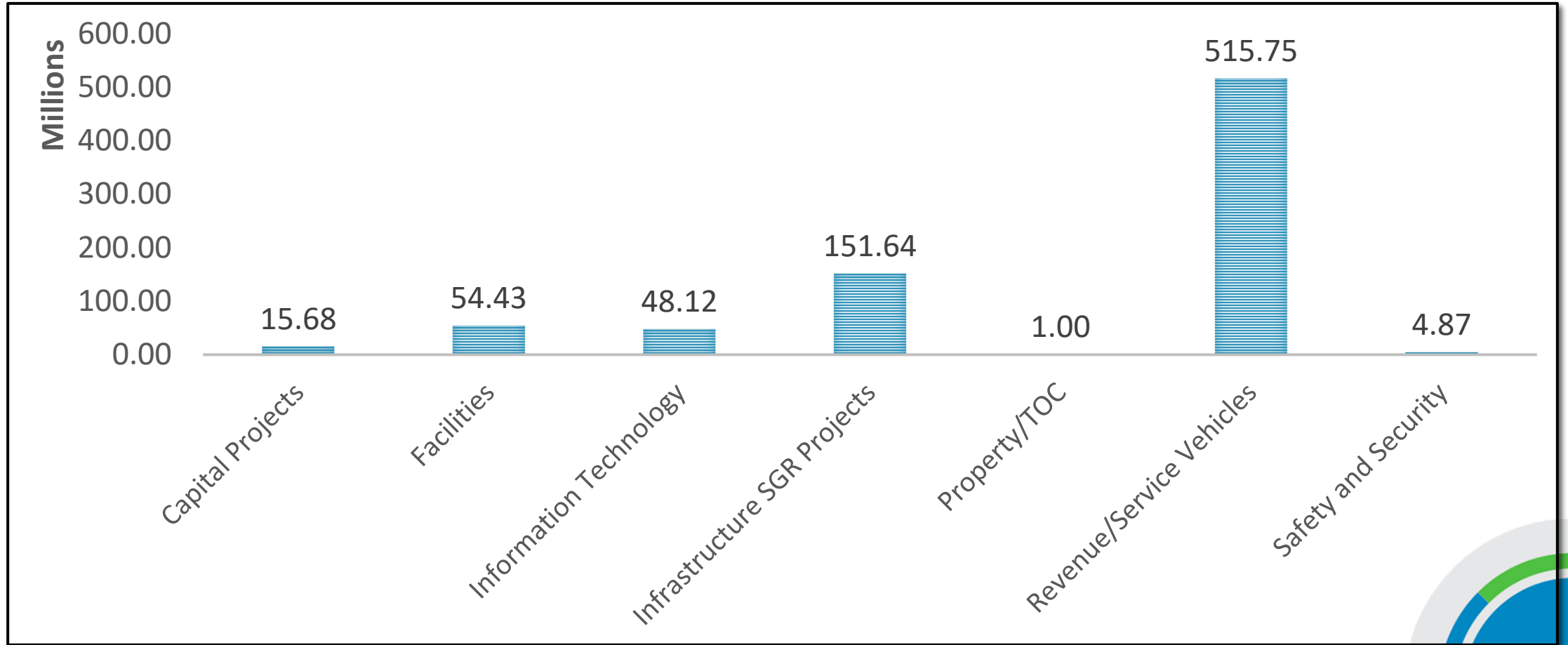

# Large Projects- 2025-2029, 57% of Plan

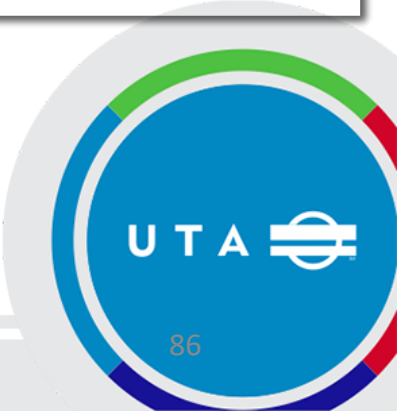
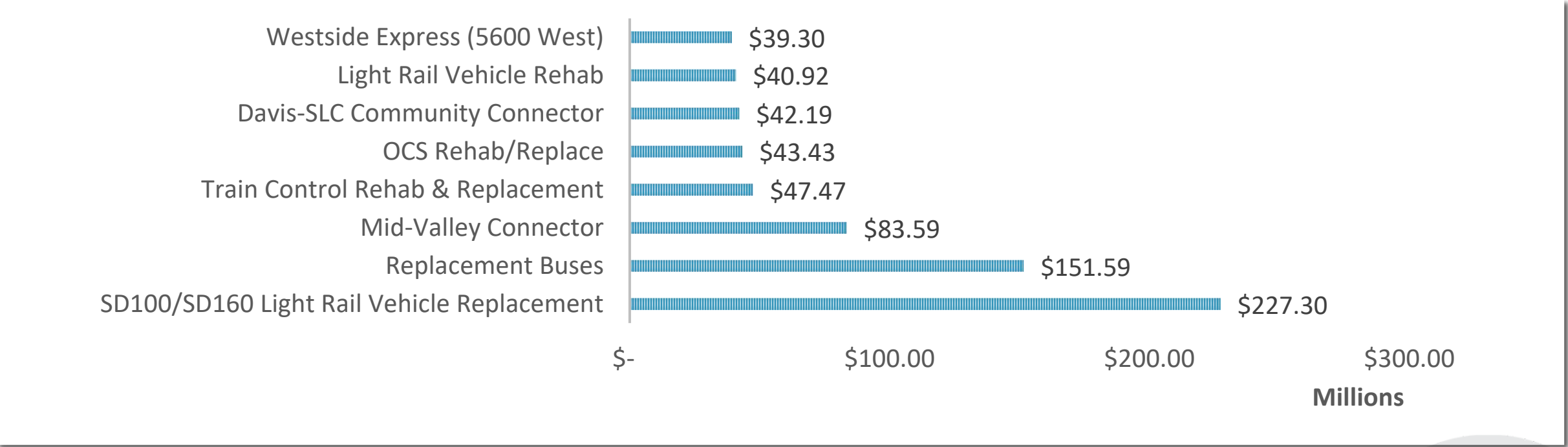

# 2025-2029 Funding Source Status

Total Budget	Bond	Executed Grants (includes Formula Funds)	Pending Grants	Lease Funds	State Funds (including TTIF)	Local Partner	UTA Funds
1,199,568,000	177,675,000	363,214,000	-	234,646,000	108,212,000	12,157,000	303,664,000

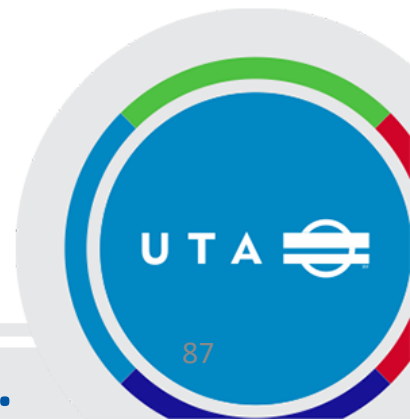

# 2025 Funding Details

Total Budget	Bond	Executed Grants	Lease Funds	State Funds (including TTIF)	Local Partner	UTA Funds
330,231,000	23,055,000	127,571,000	32,652,000	45,619,000	5,020,000	96,314,000

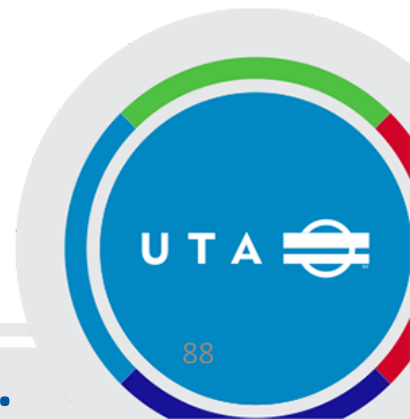

# Major 2025 Milestones

- |  |                                   |   |   |
|--|-----------------------------------|---|---|
| 5600 West Bus Construction & Bus Receipt       | MVX Construction                  | S-Line Construction                           | 90+ NRV's Received                                    |
| Jordan River 2 Construction                    | OGX 4 Additional Electric Buses   | Light Rail Vehicle Replacement Under Contract | Mt. Ogden Admin Building Begin Construction           |
| HRIS System Implementation                     | 50 of Bus Stops<br>3 of Restrooms | New Radio System NTP                          | Two Interlocking Upgrades (Rice & 450 East- Red Line) |
| New Station in South Jordan – Daybreak opening | Davis SLC Next Steps              | Techlink Next Step                            | Substation Project Completion                         |

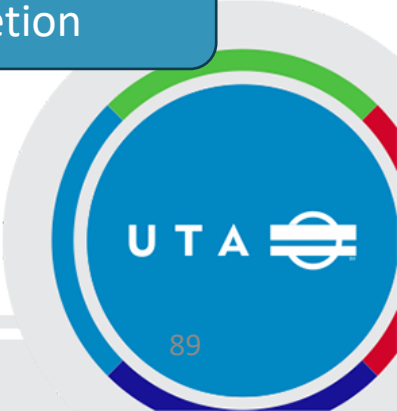

# Major 2025 Milestones

- Facilities Master Plan
- 25 CNG Buses
- 7 Grade Crossings
- Automatic Passenger Counter Upgrades
- Light Rail Vehicle Rehabilitations
- Rehab 4 San Diego Bi-Levels
- Trapeze Upgrade
- 10-Year Capital Plan
- Sustainability Master Plan
- UVX Station
- Utah County Park and Rides



# Changes from Budget Workshop

*(included in Revision 6 of the 2025-29 Capital Plan)*

- MSP252- FrontRunner 2X-
  - Anticipate increased coordination with UDOT on vehicle procurements moving forward. This would result in increases to that project with adjusted numbers going up 592,000 in 2025, 856,000 in 2026, \$1,156,000, 693,000 in 2028 and 693,000 in 2029. Total is \$3,990,000 increase to plan. These are all reimbursable costs to UDOT.
- MSP253- Mid-Valley Connector-
  - revised schedule and anticipate spending \$45 M in 2025. Moved \$15 M forward from 2027 to 2025. Zero effect on UTA dollars. Would be all state and grant funds. Plan amount remained the same.
- MSP265- Program Management Support-
  - Recognized additional UTA employees who should be billing to project. Increase of \$330,000 per year. Total of \$1.65 M over the 5-year period.
- MSP320- TRAX Modernization Program-
  - Project added for \$100,000 for each year (2025-2029). These are UTA Funds. Total increase of \$500,000
- SGR390- Jordan River 2-
  - had \$4.7 M in 2026 funding. Moved \$2.7 M of that forward to 2025 on the same project. Moved the remaining \$2.0 M to MSP267- New Training Building in 2026. Plan amount remained the same.

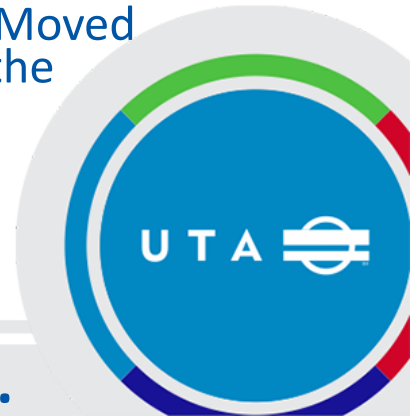

## Changes since Budget Workshop - Cont'd

*(will be added to Revision 7 of the 2025-29 Capital Plan)*

- Had duplicate MSP297 and MSP298 projects
  - Changed one MSP297 to MSP231 & MSP298 to MSP232 for separation. No changes to funding amounts
- Added MSP283- ROW Opportunity Buy as a \$0 project



# Tentative 2025 Operating and Capital Budget



# Budget Process Overview

- **Streamline overall budget schedule**
  - Allow Procurement and Talent Acquisition to start sooner in the year
- **Capital budgeting process**
  - Start with base budget
  - Executive submissions for new Capital items
  - Sync of Capital budget with Operating budget schedule

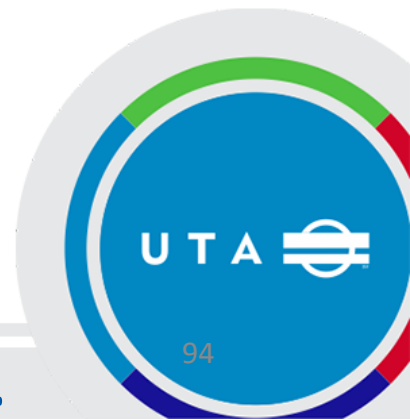

# 10-Year Financial Forecast – w/o UCE

As of 8/16/24 with bonding

**DRAFT**

	Actuals	Forecast	Forecast	Forecast	Forecast	Forecast	Forecast	Forecast	Forecast	Forecast	Forecast	Forecast
<b>Sources</b> (USD \$ Millions)	2023	2024	2025	2026	2027	2028	2029	2030	2031	2032	2033	2034
A <b>Beginning Balance</b>	\$ 435.2	\$ 373.4	\$ 356.0	\$ 324.7	\$ 259.2	\$ 231.4	\$ 216.7	\$ 167.2	\$ 184.9	\$ 215.4	\$ 226.2	\$ 244.8
Sales Tax OG	\$ 482.4	\$ 492.9	\$ 516.9	\$ 540.8	\$ 569.1	\$ 593.3	\$ 617.5	\$ 642.6	\$ 668.8	\$ 696.0	\$ 724.3	\$ 753.8
HB430 Impact			\$ (3.6)	\$ (7.5)	\$ (7.8)	\$ (8.2)	\$ (8.5)	\$ (8.9)	\$ (9.2)	\$ (9.6)	\$ (10.0)	\$ (10.4)
Sales Tax Less 4th Qtr 10%	\$ 482.4	\$ 492.9	\$ 513.3	\$ 533.3	\$ 561.3	\$ 585.2	\$ 609.0	\$ 633.8	\$ 659.6	\$ 686.4	\$ 714.3	\$ 743.4
PM Funds (FTA)	63.6	114.8	72.4	73.1	73.9	74.6	75.4	76.1	76.9	77.6	78.4	79.2
Passenger Funds	35.4	37.0	37.0	40.9	41.6	42.6	42.9	43.9	44.9	45.8	50.3	51.9
B <b>Capital Sources</b>	104.0	196.8	206.7	159.8	190.5	101.6	118.0	67.5	97.3	124.6	64.3	63.4
Bonding	-	-	60.0	-	-	-	-	-	-	-	-	-
Leasing	32.7	39.8	30.0	47.7	43.3	40.8	22.1	31.1	60.5	87.4	26.8	25.5
Grants	45.2	59.7	39.9	41.8	76.9	4.5	44.4	0.4	0.4	0.4	0.4	0.4
Formula Funds	0.1	72.3	37.1	44.6	59.4	50.0	49.1	36.0	36.4	36.7	37.1	37.5
State	17.6	21.1	2.8	5.1	2.9	5.2	1.2	-	-	-	-	-
TTIF	-	-	29.6	18.0	5.7	-	-	-	-	-	-	-
Local Revenues	8.9	3.9	7.2	2.5	2.2	1.2	1.2	-	-	-	-	-
Other	(0.5)	-	-	-	-	-	-	-	-	-	-	-
<b>Other Sources</b>	42.2	21.9	22.2	21.7	22.0	19.7	19.9	20.1	20.6	21.2	21.6	22.1
C <b>Total Sources</b>	\$ 727.6	\$ 863.3	\$ 851.5	\$ 828.8	\$ 889.2	\$ 823.5	\$ 865.2	\$ 841.5	\$ 899.2	\$ 955.6	\$ 929.0	\$ 960.0
<b>Uses</b>												
D <b>Operating Expense</b>	\$ 386.3	\$ 425.5	\$ 463.9	\$ 479.1	\$ 494.5	\$ 521.3	\$ 538.0	\$ 555.3	\$ 572.7	\$ 590.7	\$ 609.3	\$ 628.4
E <b>Capital Expense</b>	209.9	264.5	248.7	231.1	230.8	121.4	128.9	67.2	92.5	144.7	90.7	75.4
F <b>Debt Service</b>	158.8	160.6	170.2	184.0	191.8	195.5	247.9	201.2	203.6	209.4	210.3	212.5
G <b>Total Uses</b>	\$ 755.0	\$ 850.7	\$ 882.9	\$ 894.3	\$ 917.1	\$ 838.2	\$ 914.8	\$ 823.7	\$ 868.8	\$ 944.8	\$ 910.3	\$ 916.4
H <b>Net Change</b>	\$ (27.4)	\$ 12.6	\$ (31.4)	\$ (65.5)	\$ (27.8)	\$ (14.6)	\$ (49.6)	\$ 17.8	\$ 30.4	\$ 10.8	\$ 18.7	\$ 43.6
I <b>Cash Amended</b>	(34.4)	(30.0)	-	-	-	-	-	-	-	-	-	-
J <b>Ending Balance</b>	\$ 373.4	\$ 356.0	\$ 324.7	\$ 259.2	\$ 231.4	\$ 216.7	\$ 167.2	\$ 184.9	\$ 215.4	\$ 226.2	\$ 244.8	\$ 288.5
K <b>Reserves</b>	203.3	212.1	221.8	231.4	234.3	235.1	188.3	188.9	189.4	189.9	190.5	191.1
L <b>Available For Capital Investment</b>	\$ 170.2	\$ 143.9	\$ 102.9	\$ 27.8	\$ (2.9)	\$ (18.3)	\$ (21.2)	\$ (3.9)	\$ 26.0	\$ 36.2	\$ 54.4	\$ 97.4

# 10-Year Financial Forecast

As of 8/16/24 with bonding

**DRAFT**

Sources <i>(USD \$ Millions)</i>	Actuals	Forecast	Forecast	Forecast	Forecast	Forecast	Forecast	Forecast	Forecast	Forecast	Forecast	Forecast
	2023	2024	2025	2026	2027	2028	2029	2030	2031	2032	2033	2034
A <b>Beginning Balance</b>	\$ 435.2	\$ 373.4	\$ 372.0	\$ 344.8	\$ 258.3	\$ 279.7	\$ 144.8	\$ (25.4)	\$ (72.5)	\$ (103.8)	\$ (148.8)	\$ (193.3)
Sales Tax OG	\$ 482.4	\$ 492.9	\$ 516.9	\$ 540.8	\$ 564.9	\$ 588.9	\$ 612.8	\$ 637.8	\$ 663.7	\$ 690.7	\$ 718.9	\$ 748.1
HB430 Impact			\$ (3.6)	\$ (7.5)	\$ (7.8)	\$ (8.2)	\$ (8.5)	\$ (8.9)	\$ (9.2)	\$ (9.6)	\$ (10.0)	\$ (10.4)
Sales Tax Less 4th Qtr 10%	\$ 482.4	\$ 492.9	\$ 513.3	\$ 533.3	\$ 557.0	\$ 580.7	\$ 604.3	\$ 628.9	\$ 654.5	\$ 681.1	\$ 708.9	\$ 737.7
PM Funds (FTA)	63.6	114.8	72.4	73.1	73.9	74.6	75.4	76.1	76.9	77.6	78.4	79.2
Passenger Funds	35.4	37.0	37.0	40.9	41.6	42.6	46.6	47.3	49.2	50.0	50.7	52.7
B <b>Capital Sources</b>	104.0	196.8	267.1	176.0	246.1	96.8	134.8	93.2	133.5	161.2	101.4	101.0
Bonding	-	-	80.0	-	100.0	-	-	-	-	-	-	-
Leasing	32.7	39.8	38.1	49.0	63.3	46.2	73.1	21.1	60.5	87.4	26.8	25.5
Grants	45.2	59.7	66.6	65.3	32.7	4.6	0.9	12.0	12.2	12.5	12.7	13.0
Formula Funds	0.1	72.3	30.2	37.9	40.2	43.9	51.9	52.0	52.5	53.0	53.6	54.1
State	17.6	21.1	15.5	3.3	2.0	1.0	1.0	-	-	-	-	-
TTIF	-	-	29.6	18.0	5.7	-	-	-	-	-	-	-
Local Revenues	8.9	3.9	7.1	2.4	2.2	1.2	-	-	-	-	-	-
Other	(0.5)	-	-	-	-	-	8.0	8.1	8.2	8.2	8.3	8.4
Other Sources	42.2	21.9	20.8	20.3	20.6	18.7	17.7	17.7	18.7	19.1	19.2	19.5
C <b>Total Sources</b>	\$ 727.6	\$ 863.3	\$ 910.6	\$ 843.6	\$ 939.1	\$ 813.3	\$ 878.7	\$ 863.2	\$ 932.7	\$ 989.0	\$ 958.6	\$ 990.1
<b>Uses</b>												
D Operating Expense	\$ 386.3	\$ 425.5	\$ 449.2	\$ 482.1	\$ 497.8	\$ 524.8	\$ 541.9	\$ 559.5	\$ 577.7	\$ 596.6	\$ 616.0	\$ 636.0
E Capital Expense	209.9	245.3	315.1	262.0	224.7	223.9	241.2	132.4	165.6	210.9	159.0	144.8
F Debt Service	158.8	163.9	173.6	185.9	195.2	199.5	265.9	218.3	220.7	226.5	228.1	229.6
G <b>Total Uses</b>	\$ 755.0	\$ 834.7	\$ 937.8	\$ 930.1	\$ 917.7	\$ 948.2	\$ 1,049.0	\$ 910.2	\$ 964.0	\$ 1,034.0	\$ 1,003.1	\$ 1,010.4
H <b>Net Change</b>	\$ (27.4)	\$ 28.6	\$ (27.3)	\$ (86.5)	\$ 21.4	\$ (134.9)	\$ (170.3)	\$ (47.0)	\$ (31.4)	\$ (45.0)	\$ (44.5)	\$ (20.3)
I Cash Amended	(34.4)	(30.0)	-	-	-	-	-	-	-	-	-	-
J <b>Ending Balance</b>	\$ 373.4	\$ 372.0	\$ 344.8	\$ 258.3	\$ 279.7	\$ 144.8	\$ (25.4)	\$ (72.5)	\$ (103.8)	\$ (148.8)	\$ (193.3)	\$ (213.6)
K <b>Reserves</b>	203.3	222.1	245.9	272.3	247.4	264.1	231.8	247.3	263.3	279.8	296.9	314.4
L <b>Available For Capital Investment</b>	\$ 170.2	\$ 149.9	\$ 98.9	\$ (14.0)	\$ 32.4	\$ (119.2)	\$ (257.3)	\$ (319.8)	\$ (367.1)	\$ (428.6)	\$ (490.1)	\$ (528.0)

# 2025 Tentative UTA Operating Budget

## Expenses by Mode

Mode	FY 2024	FY 2025	Change	% Change
	Adj. Budget	Budget		
Bus	\$143,835,000	\$160,181,000	\$16,346,000	11.4%
Commuter Rail	38,105,000	37,674,000	(431,000)	-1.1%
Light Rail	64,499,000	66,925,000	2,426,000	3.8%
Paratransit	29,221,000	29,991,000	770,000	2.6%
Rideshare/Vanpool	4,012,000	3,954,000	(58,000)	-1.4%
Microtransit	12,949,000	16,811,000	3,862,000	29.8%
Operations Support	64,537,000	67,899,000	3,362,000	5.2%
Administration	54,048,000	63,214,000	9,166,000	17.0%
Planning/Capital Support	13,623,000	14,292,000	669,000	4.9%
Non-Departmental	682,000	1,000,000	318,000	46.6%
<b>Total Division</b>	<b>\$425,512,000</b>	<b>\$461,941,000</b>	<b>\$36,429,000</b>	<b>8.6%</b>

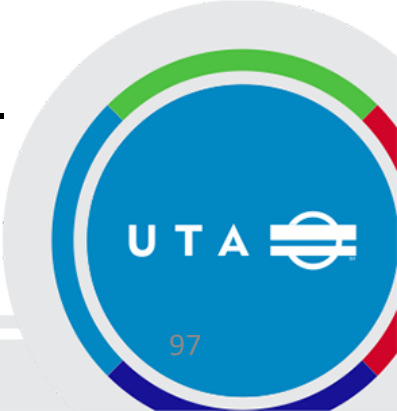

# 2025 Tentative UTA Operating Budget

## Expenses by Office

Office	FY 2024	FY 2025	Change	% Change
	Adj. Budget	Budget		
Board	\$3,370,000	\$3,517,000	\$147,000	4.4%
Executive Director	6,522,000	7,595,000	1,073,000	16.5%
Operations	319,027,000	343,300,000	24,273,000	7.6%
Finance	20,287,000	21,526,000	1,239,000	6.1%
Capital Services	7,543,000	8,183,000	640,000	8.5%
Planning & Engagement	23,144,000	27,397,000	4,253,000	18.4%
Enterprise Strategy	28,645,000	31,267,000	2,622,000	9.2%
People	12,013,000	13,343,000	1,330,000	11.1%
Communication	4,279,000	4,812,000	533,000	12.5%
Non-Departmental	682,000	1,000,000	318,000	46.6%
<b>Total Division</b>	<b>\$425,512,000</b>	<b>\$461,941,000</b>	<b>\$36,429,000</b>	<b>8.6%</b>

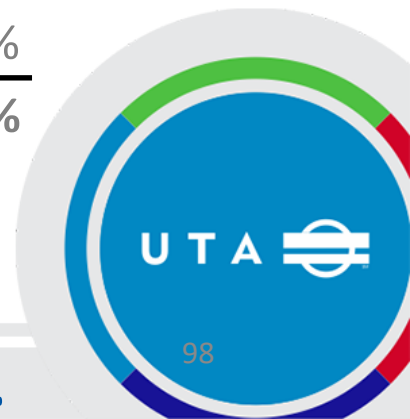

# 2025 Tentative UTA Operating Budget

## Expenses by Category

Category	FY 2024	FY 2025	Change	% Change
	Adj. Budget	Budget		
Wages	\$201,903,000	\$213,921,000	\$12,018,000	6.0%
Fringe	100,604,000	109,593,000	8,989,000	8.9%
Services	45,966,000	60,479,000	14,513,000	31.6%
Fuel/Power	35,490,000	33,711,000	(1,779,000)	-5.0%
Parts	25,904,000	29,548,000	3,644,000	14.1%
Utilities	7,373,000	7,228,000	(145,000)	-2.0%
Other O&M	20,901,000	23,562,000	2,661,000	12.7%
Capitalized Costs	(12,630,000)	(16,103,000)	(3,473,000)	27.5%
<b>Total Budget</b>	<b>\$425,512,000</b>	<b>\$461,941,000</b>	<b>\$36,429,000</b>	<b>8.6%</b>

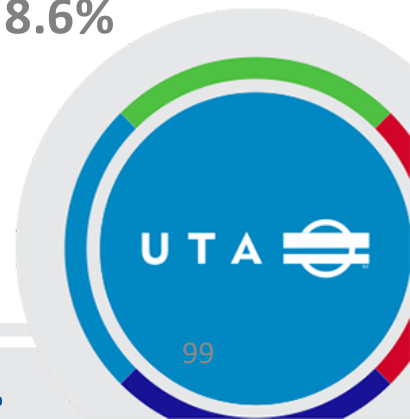

# 2025 Tentative UTA Operating Budget

## FTE Summary by Office

Office	FY 2024 Adj. Budget	FY 2025 Budget	Change	% Change
Board	16.0	15.0	(1.0)	(0.1)
Executive Director	32.5	33.5	1.0	0.0
Operations	2,328.7	2,350.7	22.0	0.0
Finance	136.0	139.0	3.0	0.0
Capital Services	59.0	64.0	5.0	0.1
Planning & Engagement	84.2	100.6	16.3	0.2
Enterprise Strategy	125.0	131.0	6.0	0.0
Communications	17.5	17.5	-	-
People	94.0	97.0	3.0	0.0
<b>Total FTE</b>	<b>2,892.9</b>	<b>2,948.2</b>	<b>55.3</b>	<b>1.9%</b>

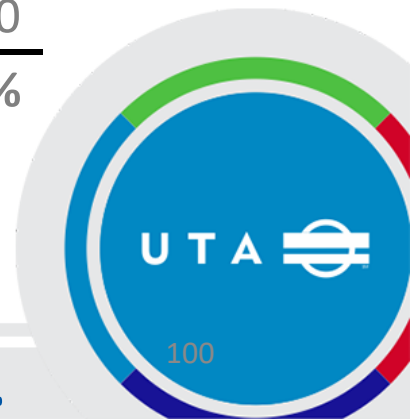

# 2025 Budget Work Session Changes

## Change

Chief	Request	2025 Total Exp	FTE Change
COO	2 Fleet Engineers returned to budget	*\$ -	2.0
	Moved 2025 New Service Expenses to Service Units	(5,653,383)	-
	Moved Salt Lake bus service to SL Bus Service Unit	4,004,928	-
	Moved Timp bus service to Timp Bus Service Unit	1,648,455	-
<b>COO Total</b>		<b>\$ -</b>	<b>2.0</b>
CPE	Cellphone adjustment	3,000	-
	Planning study adjustment	150,000	-
<b>CPE Total</b>		<b>\$ 153,000</b>	<b>-</b>
CMO	Cellphone adjustment	7,000	-
<b>CMO Total</b>		<b>\$ 7,000</b>	<b>-</b>
<b>Grand Total: 2025 Budget</b>		<b>\$ 160,000</b>	<b>2.0</b>

\*\$269,000 In Capital budget

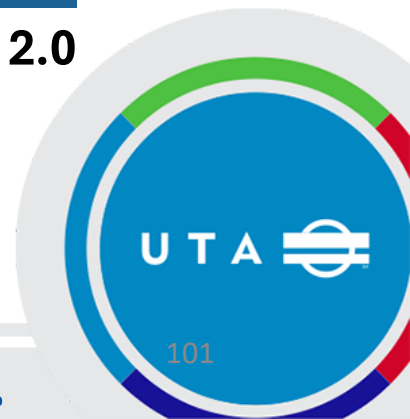

# 2025 Tentative UTA Operating Budget Changes Summary

(\$ Thousands)

2024 Adj. Budget	2024 One-Time Expenses	2024 Additions			2024 Adjustments		2025 Budget			
		Staffing	APTA/Wkg Cond/ Barg	Service	Wage and Fringe	Other	2025 Base	2025 Svc Requests	2025 Additions	2025 Budget Request
\$ 425,512	\$ (4,228)	\$ 1,991	\$ 9,816	\$ 4,008	\$ 11,918	\$ 1,967	\$ 450,984	\$ 6,843	\$ 4,114	\$ 461,941

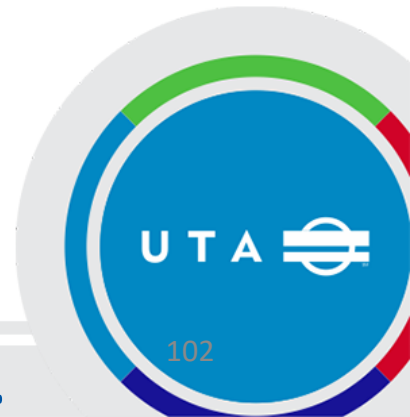

# Total Tentative 2025 Budget Request

	FY 2024 Adj. Budget	FY 2025 Budget	Change	% Change
Operating	\$425,512,000	\$461,941,000	\$36,430,000	8.6%
Capital	264,540,000	330,231,000	65,691,000	24.8%
<b>TOTAL</b>	<b>\$690,052,000</b>	<b>\$792,172,000</b>	<b>\$102,121,000</b>	<b>14.8%</b>



# 2025 Operating Budget Initiatives

## Operating Expense

Chief	Request	2025 Total Exp	FTE Change
CPE	Community Engagement staff	196,130	2.50
	On Demand - supplemental service contract	116,667	1.00
	Option 2: TRAX Ambassador Program Continuation	771,641	12.00
	Supplemental Service Ski and SGR pilot	1,900,000	-
	Planning Studies Operational Budget Increase	150,000	-
<b>CPE Total</b>		<b>\$ 3,134,438</b>	<b>15.50</b>
CES	TL3034 IT Sr. Project Manager (50% capital)	88,950	0.50
	Records Specialist Supervisor	96,000	1.00
	TL2055 Information Security Analyst II	126,300	1.00
	Network Infrastructure Architect (6 months)	77,450	1.00
	Enterprise Apps ERP Technology Administrator / Developer	154,800	1.00
	Data Governance Engineer (6 months)	51,500	1.00
	IT Asset and Inventory Analyst	-	1.00
<b>CES Total</b>		<b>\$ 595,000</b>	<b>6.50</b>
CCSO	Light Rail Vehicle Overhaul PM (80% capital)	30,400	0.20
	Commuter Rail Overhaul PM (80% capital)	30,400	0.20
	Project Controls Staff (80% capital)	48,000	0.40
	Sr Quality Inspector to Quality team (80% capital)	24,000	0.20
<b>CCSO Total</b>		<b>\$ 132,800</b>	<b>1.00</b>

Agenda Item 9.c.

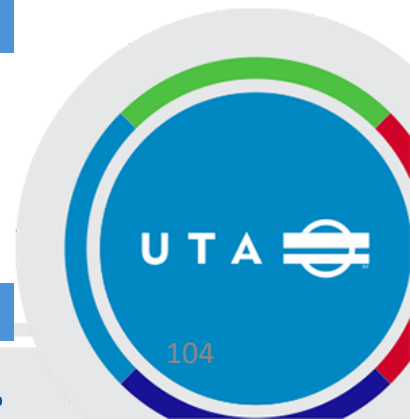

# 2025 Operating Budget Initiatives

## Operating Expense

Chief	Request	2025 Total Exp	FTE Change
CPO	Funding for PTC Training for MOW (Requirement)	123,420	-
	Maintenance Training Specialist for rail	205,500	2.00
<b>CPO Total</b>		<b>\$ 328,920</b>	<b>2.00</b>
COO	O&M Support Services	1,000,000	
<b>COO Total</b>		<b>\$ 1,000,000</b>	<b>-</b>
ED	Video Security Tech	76,966	1.00
	Legal: Policy Development Consultant	350,000	
<b>ED Total</b>		<b>\$ 426,966</b>	<b>1.00</b>
Board	Internal Audit: Consultant for Contracts Audits	200,000	
<b>Board Total</b>		<b>\$ 200,000</b>	<b>-</b>
CFO	Grants Accountant	\$ 105,000	1.00
	Work Comp Adjuster	91,000	1.00
	Grant Services Team Administrator (\$115k funded by Grant funds)	-	1.00
<b>CFO Total</b>		<b>\$ 196,000</b>	<b>3.00</b>
<b>Grand Total: Operating Budget</b>		<b>\$ 6,014,124</b>	<b>29.00</b>

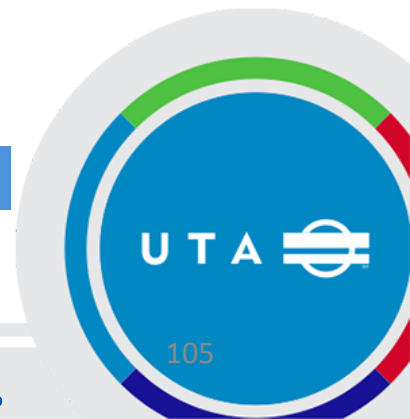

# 2025 Capital Budget Initiatives

## Capital Expense

Chief	Request	2025 Total Exp	FTE Change
CES	TL3034 IT Sr. Project Manager (50% capital)	88,950	0.50
<b>CES Total</b>		<b>\$ 88,950</b>	<b>0.50</b>
CCSO	Light Rail Vehicle Overhaul PM (80% capital)	152,000	0.80
	Commuter Rail Overhaul PM(80% capital)	152,000	0.80
	Project Controls Staff (80% capital)	240,000	1.60
	Sr Quality Inspector to Quality team (80% capital)	120,000	0.80
<b>CCSO Total</b>		<b>\$ 664,000</b>	<b>4.00</b>
<b>Grand Total: Capital Budget</b>		<b>\$ 752,950</b>	<b>4.50</b>

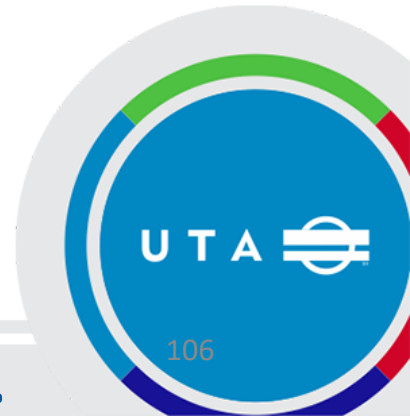

# 2025 Key Budget Assumptions

## Operating Expenses:

- Labor 3.5% Bargaining, 4% Admin
- Fringe 4.5% Bargaining, 9% Admin
- Parts – 3.5%
- Fuel:
  - Diesel - \$3.60
  - Gasoline - \$3.10
  - CNG DGE - \$2.15
- Other Expense ~2.2% (may vary due to contract)

## Revenues:

- Sales Tax – 4.9%
- Passenger – 0.0%

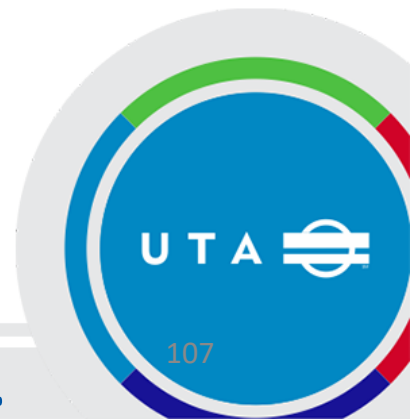

# UTA Sales Tax Growth 2020 - 2024

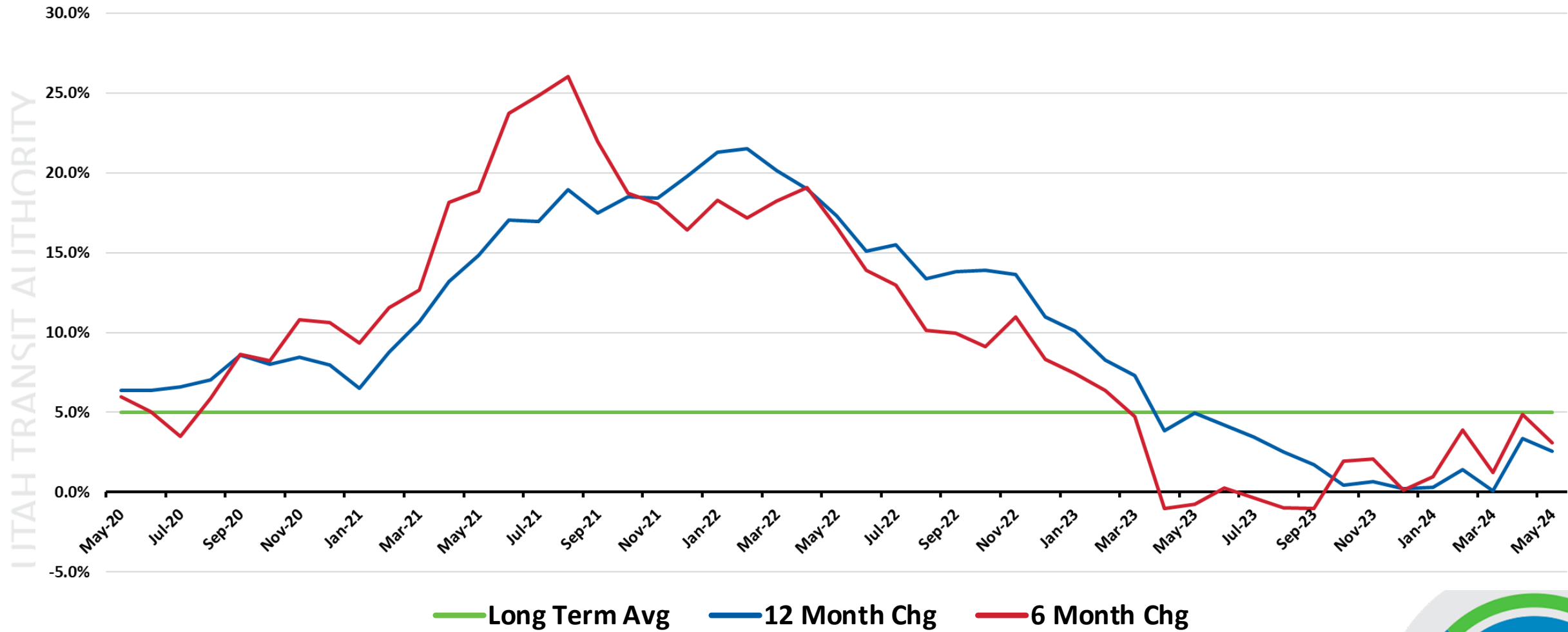

9/11/2024

Agenda Item 9.c.

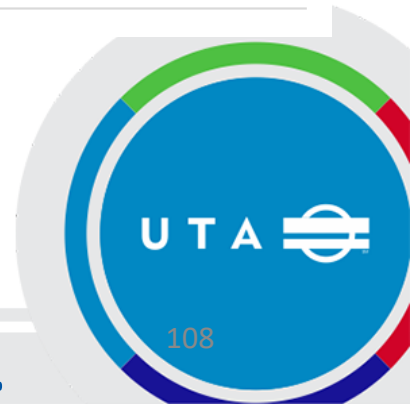

# Sources and Uses

## Where the Money Comes From

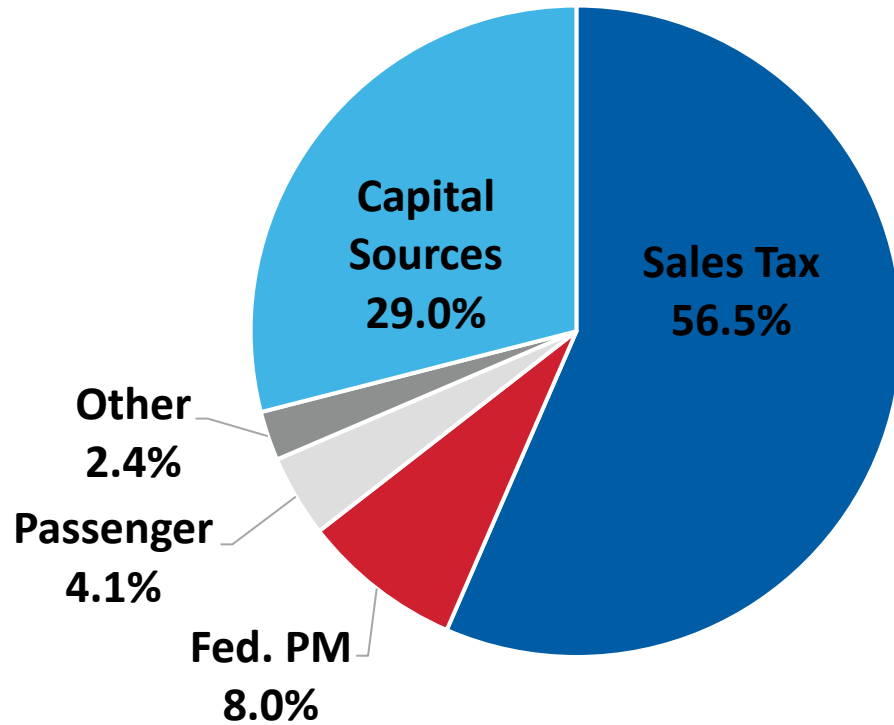

## Where the Money Goes

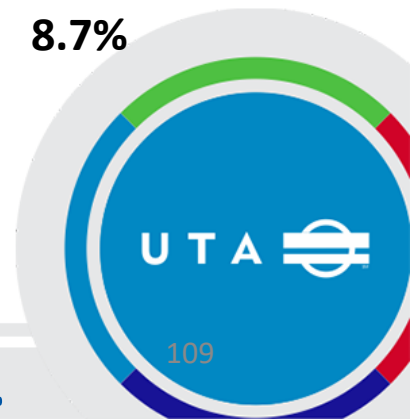
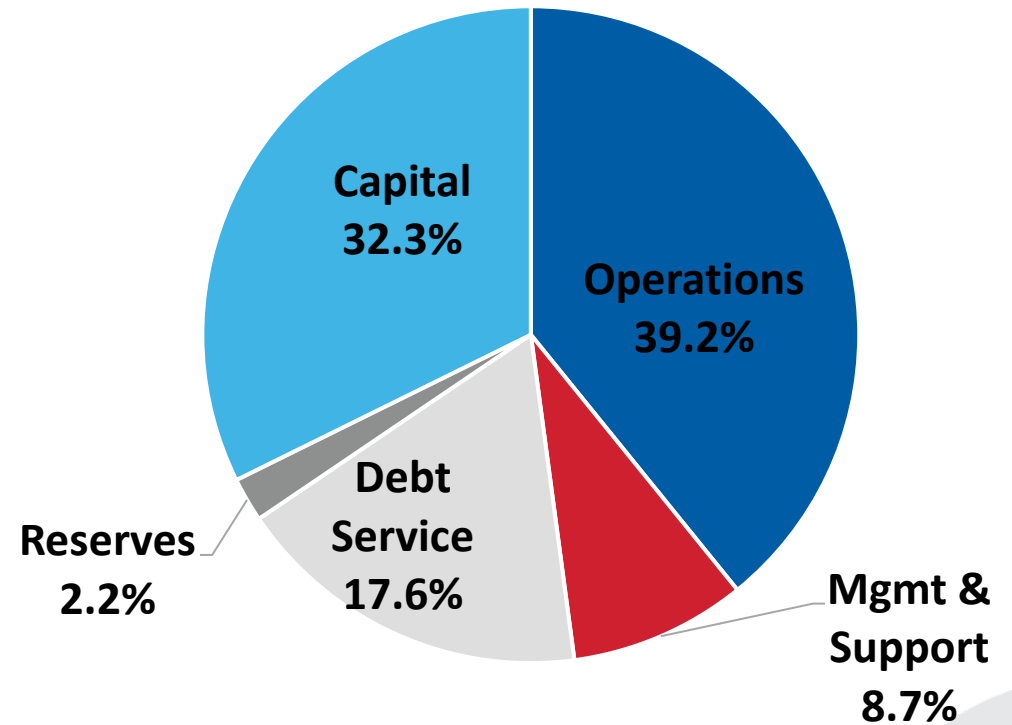

# 2025 Tentative Capital Budget



# 2025 Tentative Capital Budget Overview

Office	2025 Total Budget
Capital Services	\$276,029,000
Enterprise Strategy	15,809,000
Executive Director (Safety)	1,996,000
Finance	21,211,000
Operations	9,700,000
People	2,145,000
Planning & Engagement	3,341,000
<b>Grand Total</b>	<b>\$330,231,000</b>

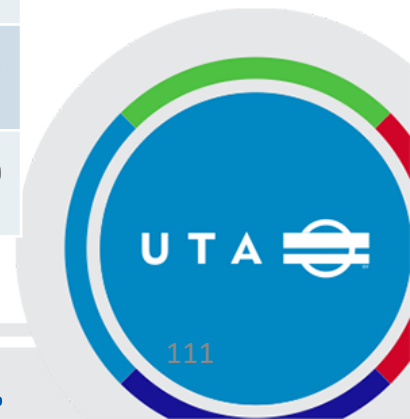

# 2025 Capital Budget Work Session Changes

## Change

Project	Request	2025 Exp Increase
MSP 252 FrontRunner 2x	Vehicle procurement partnership with UDOT	\$ 592,000
MSP 253 MidValley Connector	Revised project schedule forward to 2025	15,000,000
MSP 265 Program Mgmt.	Additional employee's capital billing to projects	330,000
MSP 320 TRAX Modernization	Increase yearly funding	100,000
SGR 390 Jordan River #2	Revised project schedule forward to 2025	2,700,000
<b>Grand Total: 2025 Budget</b>		<b>\$ 18,722,000</b>

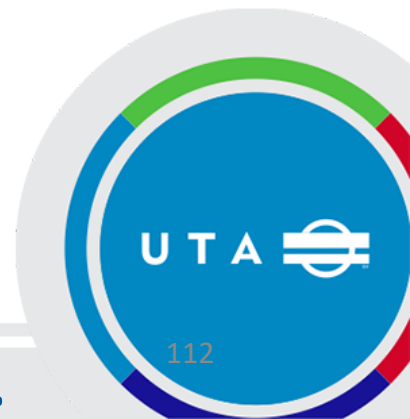

# 2025 Capital Funding Details

Total Budget	Bond	Executed Grants	Lease Funds	State Funds (including TTIF)	Local Partner	UTA Funds
\$330,231,000	\$23,055,000	\$127,571,000	\$32,652,000	\$45,619,000	\$5,020,000	\$96,314,000

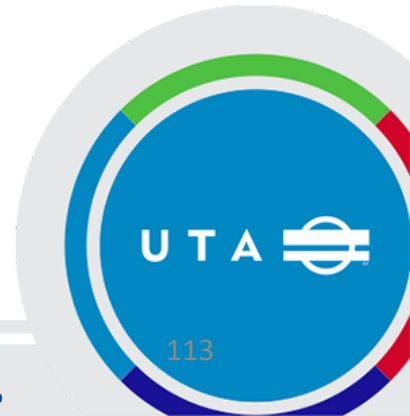

# Major 2025 Capital Milestones

- |  |                                   |   |  |
|--|-----------------------------------|---|--|
| 5600 West Bus Construction & Bus Receipt       | MVX Construction                  | S-Line Construction                           | 90+ NRV's Received                                     |
| Jordan River 2 Construction                    | OGX 4 Additional Electric Buses   | Light Rail Vehicle Replacement Under Contract | Mt. Ogden Admin Building Begin Construction            |
| HRIS System Implementation                     | 50 of Bus Stops<br>3 of Restrooms | New Radio System NTP                          | Two Interlocking Upgrades (Rice & 450 East – Red Line) |
| New Station in South Jordan – Daybreak opening | Davis SLC Next Steps              | Techlink Next Step                            | Substation Project Completion                          |

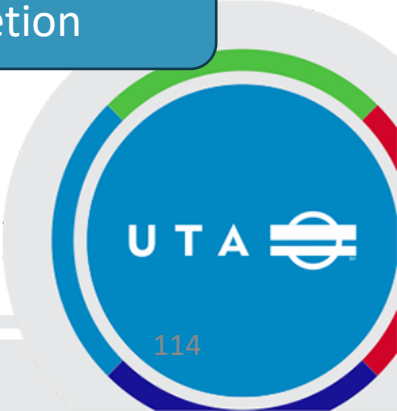

# Major 2025 Capital Milestones

Facilities Master Plan

25 CNG Buses

7 Grade Crossings

Automatic Passenger Counter Upgrades

Light Rail Vehicle Rehabilitations

Rehab 4 San Diego Bi-Levels

Trapeze Upgrade

10-Year Capital Plan

Sustainability Master Plan

UVX Station

Utah County Park and Rides



# Next Steps

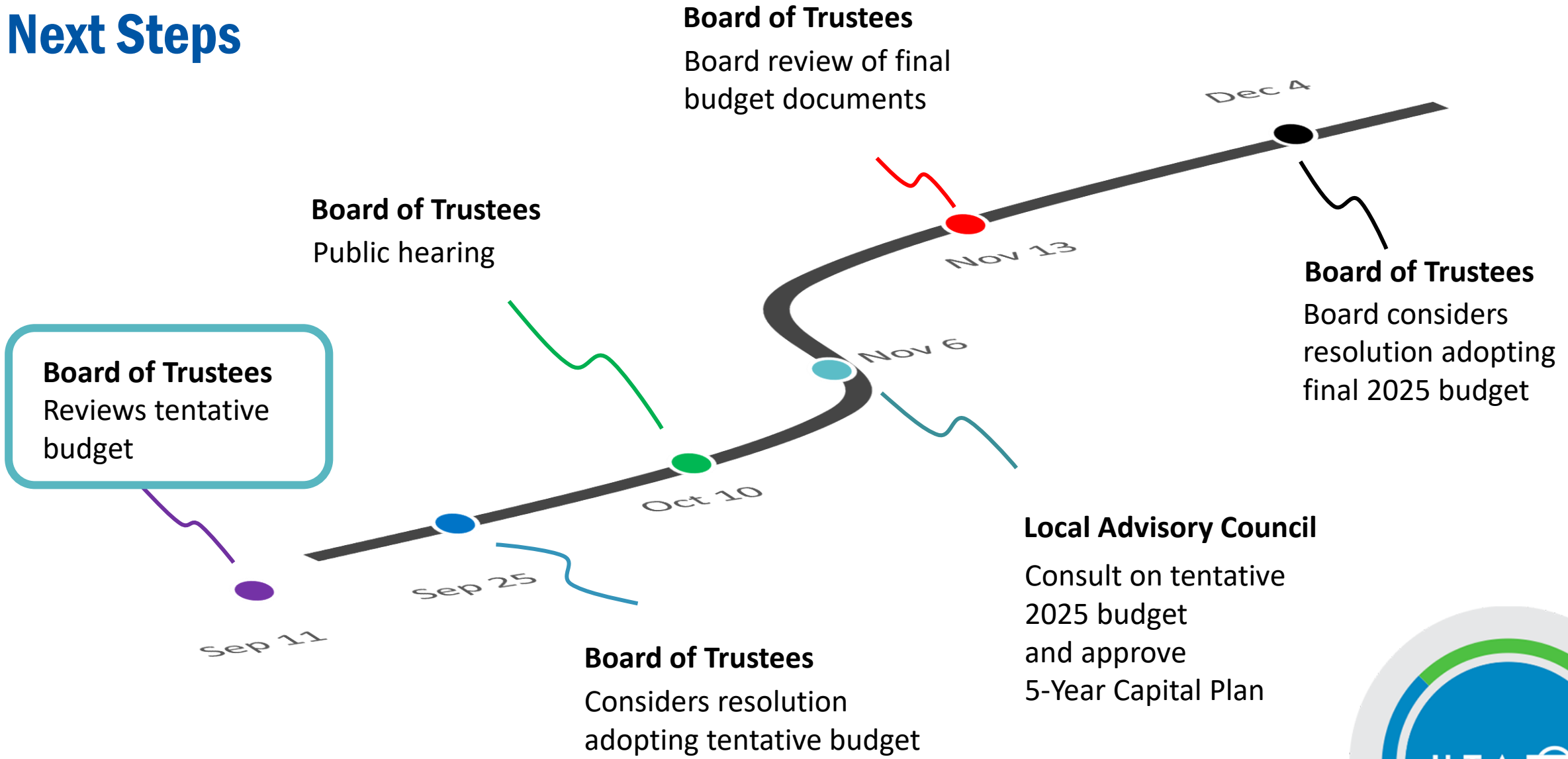

7/11/2024



# Customer Experience Action Plan



# Welcome!



**Evan Chan**



**Bob Ruediger**



# What is Customer Experience (CX)?

For UTA, Customer Experience is everything a customer experiences on their transit journey, from front door → final destination.

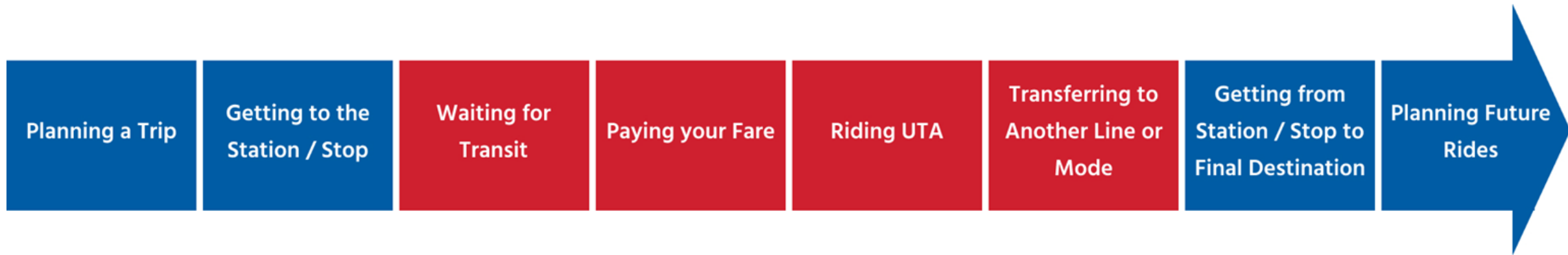

**From the customer's perspective, it's all one experience.**



# Why does Customer Experience (CX) matter?

- Businesses that prioritize CX grow their revenue **1.7 times** faster than businesses that don't. (*Forrester*)
- **66%** of businesses that prioritize CX see increased retention, and **60%** see an increase in customer lifetime value. (*Forrester*)
- **92%** of customers around the world say they trust recommendations from friends and family more than other forms of advertising. (*Nielsen*)



# What is a Customer Experience (CX) Action Plan?

It is a document that communicates

1. **Who** our customers are and what matters to them
2. **What** our customers experience
3. A **roadmap** of CX projects and priorities over the next several years



# What is a Customer Experience (CX) Action Plan?

We're building on the great work done by other transit authorities.



Translink

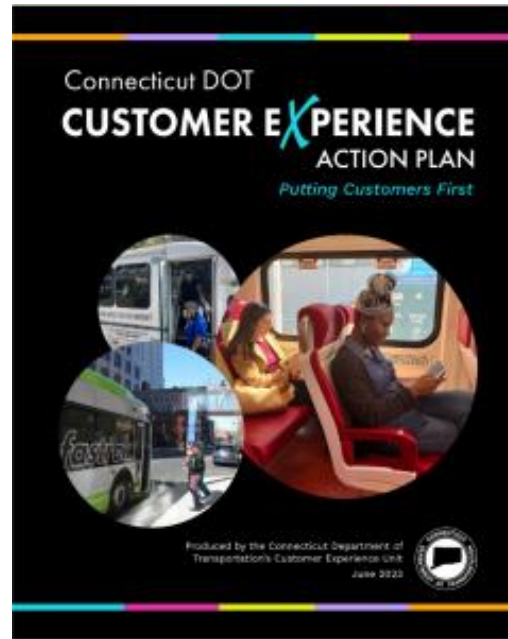

CTDOT

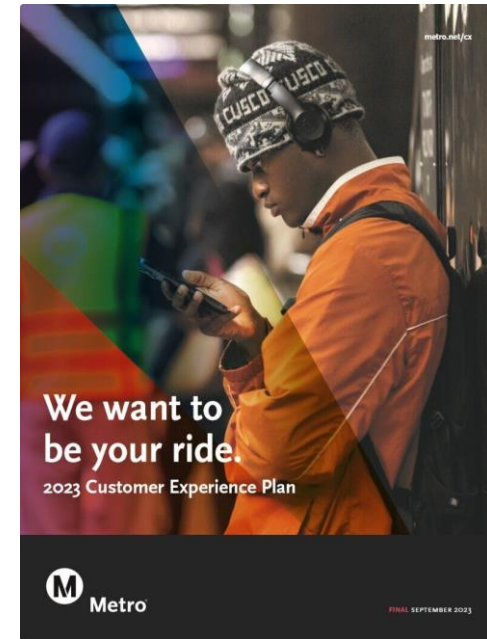

LA Metro

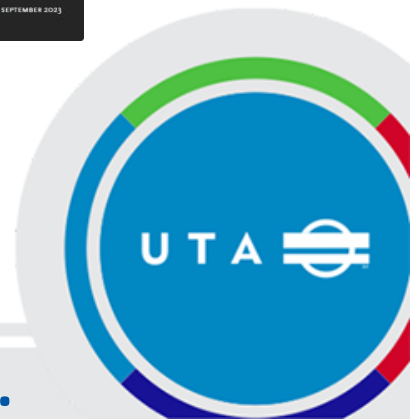

# What is a Customer Experience (CX) Action Plan?

It is a document that communicates

1. **Who** our customers are and what matters to them
2. What our customers experience
3. A roadmap of CX projects and priorities over the next several years

**We've changed the way we think about our customers, and we are focused on five different mindsets to help tailor the work we do for each unique customer.**



## ACCESSIBLE

Customers with an accessible mindset have varying levels of mobility and are independent and resourceful. They primarily rely on our HandyDART service, though many also use our bus, SeaBus, SkyTrain, and West Coast Express services. They seek accessible and inclusive services that enable them to travel independently. They go out of their way to plan travel well in advance to ensure the smoothest trip possible.



## PRACTICAL

Customers tend to be in a practical frame of mind when reliability and convenience are paramount, like when they're going to work or heading to the store for their routine Sunday grocery shop. These customers seek routine, dependability, and cost savings. Many of them are frequent riders who are familiar with our system, and transit is critical to their livelihoods.



## FLEXIBLE

At other times, our customers have a more flexible mindset, in which they value simplicity and timeliness. They may make spontaneous decisions about the mode of transportation they take, depending on factors like weather or mood. At these times, they're comfortable with ambiguity and making trade-offs as they go.



## CAUTIOUS

Sometimes customers feel more cautious and vigilant, especially during winter conditions or late at night. Safety and cleanliness are usually top of mind. They may travel only when absolutely necessary, or alter their transportation routines to reduce any anxiety. They will often increase the complexity of their trip if it means that will reduce their anxiety.



## ADVANTAGEOUS

Tactical customers are looking for the hassle-free option. These customers often have a private vehicle to default to when it suits them best, but they will take transit if it saves them both time and money. Pricing and comfort are paramount: these customers value freedom to move, however and whenever they want.

# What is a Customer Experience (CX) Action Plan?

It is a document that communicates

1. Who our customers are and what matters to them
2. **What** our customers experience
3. A roadmap of CX projects and priorities over the next several years

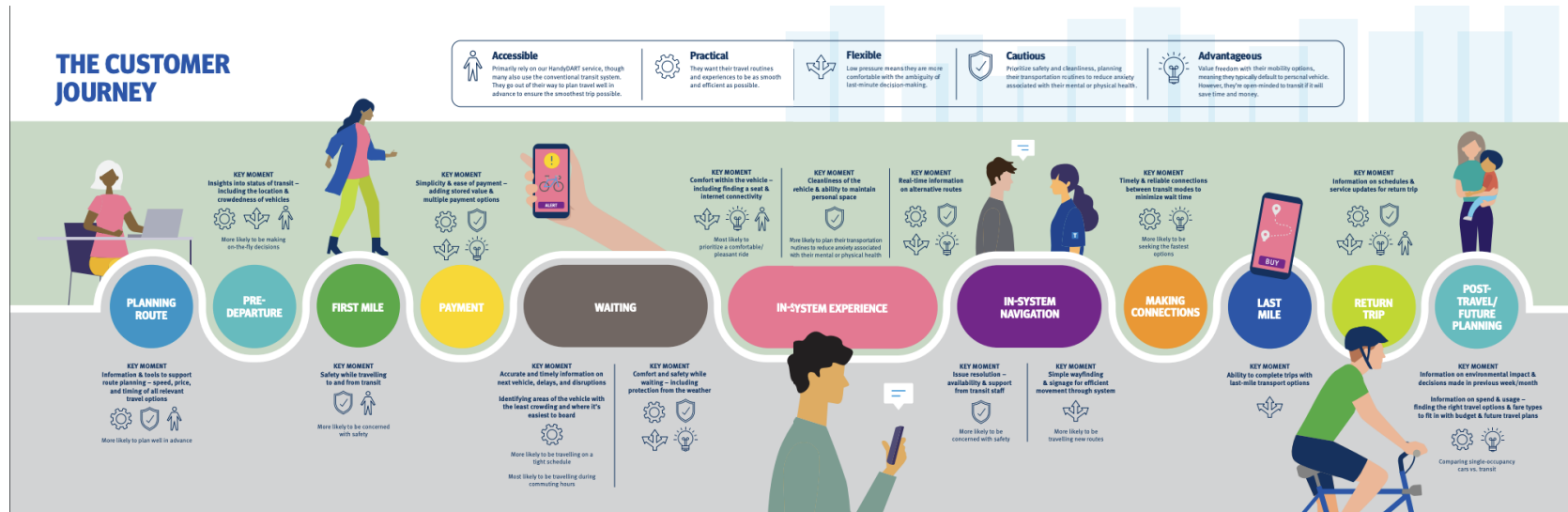

# What is a Customer Experience (CX) Action Plan?

It is a document that communicates

1. Who our customers are and what matters to them
2. What our customers experience
3. **A roadmap of CX projects and priorities over the next several years**

### Our Five Priorities for the Next Five Years

-  **MORE PERSONALIZED**  
We tailor our services to meet your needs and preferences.  
*"TransLink offers me incentives and information tailored to my interests or priorities. I don't have to seek it out – it's all sent to me, so I don't have to"*
-  **EASIER TO USE**  
A service that is effortless and convenient to use.  
*"My Compass Card is on auto-load so I never have to stop to refill it. Plus if there's a delay and I need to reroute. Transit is part of my daily routine how easy it is to use."*
-  **TIMELY & RELIABLE**  
Ensure that our riders can rely on transit to get them where to go, on time and without hiccups.  
*"I've taken transit in cities all over the world, and I'm always so impressed prompt, reliable, and convenient TransLink is. It's a seamless network I navigate and always gets me where I'm going on time."*
-  **SAFE & PLEASANT**  
An environment where riders feel they will have an enjoyable welcoming experience.  
*"I feel safe travelling on the transit system any time of the day or night, and it's easy to call for help if I need it. Starting my day off by taking transit makes me feel good, and it makes me feel connected to and a part of our city."*
-  **A BETTER REASON TO RIDE**  
Position transit as an opportunity to make a difference.  
*"I take transit because it's the socially responsible thing to do. When it's nice out, I take my bike or walk. It's important we all start making better decisions that will reduce our carbon footprint and help save our planet."*



**Real-Time GTFS**  
**STATUS - Completed**  
Use Metro's new prediction engine, Swiftly, to publish an improved real-time feed (GTFS-Real Time) that incorporates canceled service, delay advisories and service alerts.



**Metro Westlake/MacArthur Park Station Improvements**  
**STATUS - In Progress**  
Metro took action to improve safety and the overall customer experience at the station, including:  
> Increased presence of multidisciplinary teams (Metro Ambassadors, homelessness partners, custodians and law enforcement)  
> Improved station lighting  
> Added more and better closed-circuit cameras  
> Classical music inside the station  
> Closed one underused station entrance  
> Fenced off unused areas of the street-level plaza  
> Partnered with Department of Health Services to have a mobile clinic twice a month  
Following an assessment, these actions will be expanded to additional priority stations.



**Accessible Navigation Applications**  
**STATUS - In Progress**  
Engage with an accessibility application provider to pilot and test innovative mobile apps that remove barriers to accessing Metro.



**Metro Micro Pilot**  
**STATUS - In Progress**  
Launched in 2020, the Metro Micro pilot provides on-demand, shared microtransit services in seven service zones across the county. Frequency, reliability, and travel speeds are of high importance to our riders and non-riders.  
As part of the continued evaluation of this service, Metro conducted the first Customer Experience Rider survey for Metro Micro riders in Spring 2022. The results showed high levels of satisfaction across all the aspects of service, including safety, ease of use, cleanliness and comfort. Some areas of improvement related to booking the ride and the timeliness of the service.



# Why Does Having a CX Action Plan Matter?

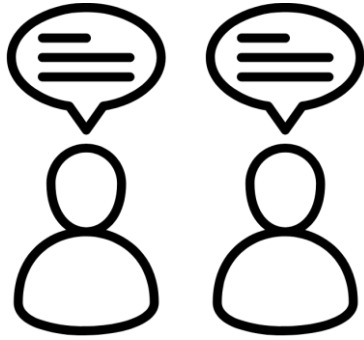

It will foster a **shared understanding and language** across UTA about what matters to riders and what they experience.

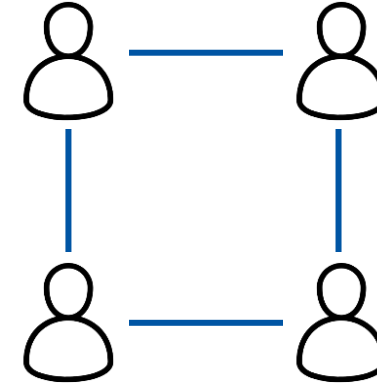

It will facilitate **coordination of projects** across UTA departments and teams.



# General Structure of the Project

1. Align on approach (*March*)



# General Structure of the Project

1. Align on approach (*March*)
2. Establish structure for CX Action Plan (*April*)



# General Structure of the Project

1. Align on approach (*March*)
2. Establish structure for CX Action Plan (*April*)
3. Engage riders, community partners, and UTA staff to understand the experience (*June – Aug.*)



*Tabling at Partners in the Park*



# General Structure of the Project

1. Align on approach (*March*)
2. Establish structure for CX Action Plan (*April*)
3. Engage riders, community partners, and UTA staff to understand the experience (*June – Aug.*)
4. Engage UTA staff and riders to prioritize ideas (*Sept. – Oct.*)



*Staff workshop*



# General Structure of the Project

1. Align on approach (*March*)
2. Establish structure for CX Action Plan (*April*)
3. Engage riders, community partners, and UTA staff to understand the experience (*June – Aug.*)
4. Engage UTA staff and riders to prioritize ideas (*Sept. – Oct.*)



*Engage riders and community groups to prioritize ideas*



# General Structure of the Project

1. Align on approach (*March*)
2. Establish structure for CX Action Plan (*April*)
3. Engage riders, community partners, and UTA staff to understand the experience (*June – Aug.*)
4. Engage UTA staff and riders to prioritize ideas (*Sept. – Oct.*)
5. **Write the Plan (*Nov. – Dec.*)**



# Any questions?



# Implementation of New Technologies Budget Work Session Follow-up



# Chief Enterprise Strategy Office Budget Follow-up

Alisha Garrett, Kyle Brimley, Tigran Melikyan



# Process for Onboarding Enterprise Systems

## Business Need

- New
- Update
- Change

## Technical Business Review

- Customer Requirements
- Capture Current & Desired State

## Evaluation

- Review Options
- Review Similar Needs
- Identify Priorities

## Procurement

- Determine Buys vs Build
- Procurement Process
- Adhere to InfoSecurity
- Adhere to Data Requirements

## Implementation

- Partnership with Clients
- Shared Work

## Ongoing Support

- Updates
- Security
- Data
- Reporting
- Coordination
- Administrative Roles



# Benefits of Enterprise Applications

- Process efficiency
- Streamlined workflows
- Reduction of duplicative applications
- Less customization and more configuration
- Improved accuracy and availability of data
- Increase in standardization across the organization
- Ability to serve multiple client groups with the same technology solution
- Increase collaboration and cross functional work processes
- Integrating with new and existing systems
- Define administrative roles and responsibilities



# Labor Relations Overview



# Labor Relations at UTA

- Utah Public Transit District Act provides certain employees the right to bargain collectively through representatives of their choosing with respect to:
  - Wages
  - Salaries
  - Hours
  - Working conditions
  - Welfare, pension and retirement provisions
- UTA currently has two represented groups:
  - Operators, Mechanics and Parts employees represented by Amalgamated Transit Union (ATU), Local 382
  - TRAX Supervisors represented by Teamsters, Local 222



# Labor Relations Processes

- Collective Bargaining
  - Collective Bargaining Agreement (CBA)
  - Requests to bargain on new mandatory issues
- Grievances and Discipline Reviews
  - Complaint or concern regarding the interpretation of the CBA
  - Complaint or concern regarding disciplines issued for represented employees
- Processes for grievances and disciplines are negotiated in the respective CBAs with both ATU and Teamsters.



# Other Business

- a. Next Meeting: Wednesday, September 25, 2024, at 9:00 a.m.



# Adjourn

